



# Quad Bus Transceivers With 3-State Outputs

ELECTRICALLY TESTED PER:  
MIL-M-38510/32802

The 54LS243 is a Quad Bus Transmitter/Receiver designed for 4-line asynchronous 2-way data communications between data buses.

- Hysteresis at Inputs to Improve Noise Margins
- 2-Way Asynchronous Data Bus Communications
- Input Clamp Diodes Limit High-Speed Termination Effects

### LOGIC DIAGRAM

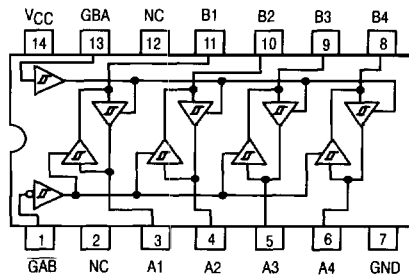

### TRUTH TABLE

Inputs		Output
GAB	D	
L	L	L
L	H	H
H	X	(Z)

### TRUTH TABLE

Inputs		Output
GBA	D	
L	X	(Z)
H	L	L
H	H	H

H = HIGH Voltage Level  
L = LOW Voltage Level  
X = Immaterial  
Z = HIGH Impedance

## Military 54LS243



### AVAILABLE AS:

- 1) JAN: JM38510/32802BXA
- 2) SMD: 8002002
- 3) 883: 54LS243/BXAJC

X = CASE OUTLINE AS FOLLOWS:  
PACKAGE: CERDIP: C  
CERFLAT: D  
LCC: 2

THE LETTER "M" APPEARS  
BEFORE THE / ON LCC.

### PIN ASSIGNMENTS

FUNCT.	DIL 632-08	FLATS 717-04	LCC 756A-02	BURN-IN (COND. A)
GAB	1	1	2	VCC
NC	2	2	3	VCC
A1	3	3	4	VCC
A2	4	4	6	VCC
A3	5	5	8	VCC
A4	6	6	9	VCC
GND	7	7	10	GND
B4	8	8	12	VCC
B3	9	9	13	VCC
B2	10	10	14	VCC
B1	11	11	16	VCC
NC	12	12	18	VCC
GBA	13	13	19	VCC
VCC	14	14	20	VCC

BURN-IN CONDITIONS:  
V<sub>CC</sub> = 5.0 V MIN/6.0 V MAX

# 54LS243

## AC TEST CIRCUIT

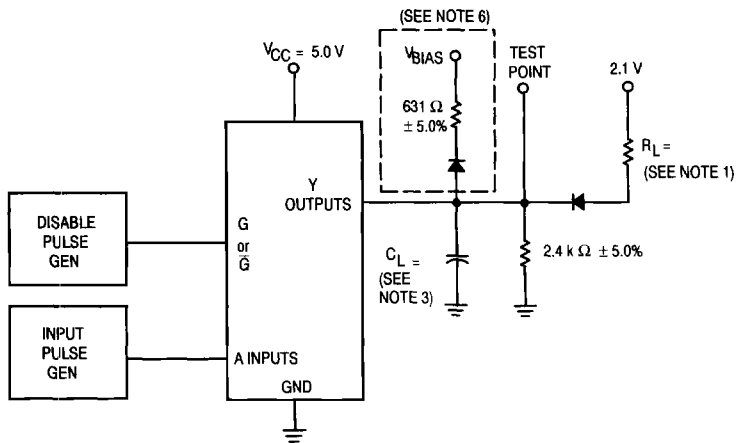

## VOLTAGE WAVEFORMS PROPAGATION DELAY TIMES

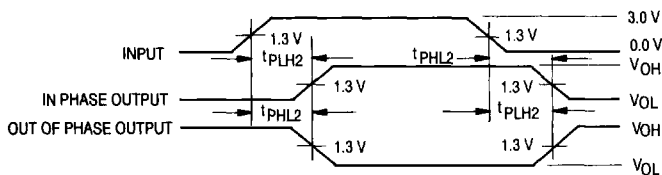

## VOLTAGE WAVEFORMS ENABLE AND DISABLE TIMES, THREE-STATE OUTPUTS

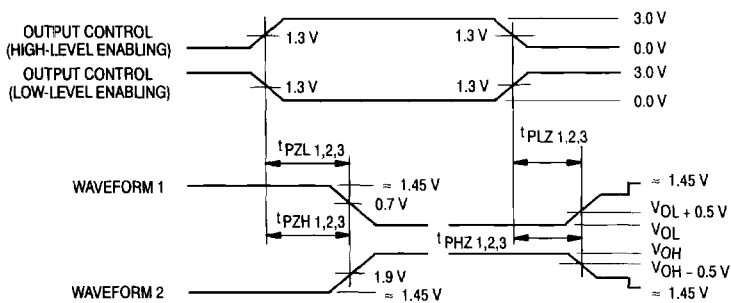

REFERENCE NOTES ON PAGE 5-309

Symbol	Parameter	Limits						Unit	Test Condition (Unless Otherwise Specified)
		+ 25°C		+ 125°C		- 55°C			
		Subgroup 1		Subgroup 2		Subgroup 3			
		Min	Max	Min	Max	Min	Max		
V <sub>OHH</sub>	Logical "1" Output Voltage	2.4		2.4		2.4		V	V <sub>CC</sub> = 4.5 V, I <sub>OH</sub> = - 3.0 mA, V <sub>IN</sub> = 2.0 V (all inputs), $\bar{G}AB/GBA = 0.7 V$ or 2.0 V per truth table.
V <sub>OHL</sub>	Logical "1" Output Voltage	2.0		2.0		2.0		V	V <sub>CC</sub> = 4.5 V, I <sub>OH</sub> = - 12 mA, V <sub>IN</sub> = 2.0 V (all inputs), $\bar{G}AB/GBA = 2.0 V$ or 0.5 V per truth table.
V <sub>OL</sub>	Logical "0" Output Voltage		0.4		0.4		0.4	V	V <sub>CC</sub> = 4.5 V, I <sub>OL</sub> = 12 mA, V <sub>IN</sub> = 0.7 V (all inputs), $\bar{G}AB/GBA = 2.0 V$ or 0.7 V per truth table.
V <sub>IC</sub>	Input Clamping Voltage		- 1.5					V	V <sub>CC</sub> = 4.5 V, I <sub>IN</sub> = - 18 mA, other inputs are open, $\bar{G}AB/GBA = GND$ , open, 5.5 V, 4.5 V per truth table.
I <sub>IH</sub>	Logical "1" Input Current		20		20		20	μA	V <sub>CC</sub> = 5.5 V, V <sub>IH</sub> = 2.7 V, other inputs are open, $\bar{G}AB/GBA = 5.5 V, 2.7 V$ or GND per truth table.
I <sub>IHH</sub>	Logical "1" Input Current		100		100		100	μA	V <sub>CC</sub> = 5.5 V, V <sub>IHH</sub> = 5.5 V, other inputs are open, $\bar{G}AB/GBA = 0 V, 4.5 V, 5.5 V$ or open per truth table.
I <sub>IL</sub>	Logical "0" Input Current	0	- 150	0	- 150	0	- 150	μA	V <sub>CC</sub> = 5.5 V, V <sub>IN</sub> = 0.4 V, other inputs are open, $\bar{G}AB/GBA = GND, 0.4 V, 4.5 V, 5.5 V$ per truth table.
I <sub>OS</sub>	Output Short Circuit Current	- 40	- 225	- 40	- 225	- 40	- 225	mA	V <sub>CC</sub> = 5.5 V, V <sub>IN</sub> = 5.5 V all inputs, V <sub>OUT</sub> = GND, $\bar{G}AB/GBA = GND$ or 5.5 V per truth table.
I <sub>IOZH</sub>	Output Off Current High		20		20		20	μA	V <sub>CC</sub> = 5.5 V, V <sub>IN</sub> = 2.7 V, other inputs are open, $\bar{G}AB = 2.0 V$ or open, GBA = 0.7 V or open.
I <sub>IOZL</sub>	Output Off Current Low		- 200		- 200		- 200	μA	V <sub>CC</sub> = 5.5 V, V <sub>IN</sub> = 0.4 V, other inputs are open, $\bar{G}AB = 2.0 V$ or open, GBA = 0.7 V or open.
I <sub>CCH</sub>	Power Supply Current		38		38		38	mA	V <sub>CC</sub> = 5.5 V, V <sub>IN</sub> = 5.5 V (all inputs), $\bar{G}AB/GBA = GND$ .
I <sub>CCL</sub>	Power Supply Current		50		50		50	mA	V <sub>CC</sub> = 5.5 V, V <sub>IN</sub> = GND (all inputs).
I <sub>CCZ</sub>	Power Supply Current Off		50		50		50	mA	V <sub>CC</sub> = 5.5 V, all inputs are open, $\bar{G}AB = 5.5 V, GBA = GND$ .
V <sub>IH</sub>	Logical "1" Input Voltage	2.0		2.0		2.0		V	V <sub>CC</sub> = 4.5 V.
V <sub>IL</sub>	Logical "0" Input Voltage		0.7		0.7		0.7	V	V <sub>CC</sub> = 4.5 V.
	Functional Tests	Subgroup 7		Subgroup 8A		Subgroup 8B			per Truth Table with V <sub>CC</sub> = 5.0 V, V <sub>INL</sub> = 0.4 V, and V <sub>INH</sub> = 2.4 V.

## 54LS243

Symbol	Parameter	Limits						Unit	Test Condition (Unless Otherwise Specified)
		+ 25°C		+ 125°C		- 55°C			
		Subgroup 9		Subgroup 10		Subgroup 11			
		Min	Max	Min	Max	Min	Max		
t <sub>PHL2</sub> t <sub>PHL2</sub>	Propagation Delay /Data-Output Output High-Low	2.0 —	23 18	2.0 —	30 25	2.0 —	30 25	ns	V <sub>CC</sub> = 5.0 V, C <sub>L</sub> = 50 pF, R <sub>L</sub> = 110 Ω. V <sub>CC</sub> = 5.0 V, C <sub>L</sub> = 45 pF, R <sub>L</sub> = 667 Ω.
t <sub>PLH2</sub> t <sub>PLH2</sub>	Propagation Delay /Data-Output Output Low-High	2.0 —	19 18	2.0 —	25 23	2.0 —	25 23	ns	V <sub>CC</sub> = 5.0 V, C <sub>L</sub> = 50 pF, R <sub>L</sub> = 110 Ω. V <sub>CC</sub> = 5.0 V, C <sub>L</sub> = 45 pF, R <sub>L</sub> = 667 Ω.
t <sub>PLZ1</sub> t <sub>PLZ1</sub>	Propagation Delay /Data-Output Output Low-High	2.0 —	30 25	2.0 —	39 34	2.0 —	39 34	ns	V <sub>CC</sub> = 5.0 V, C <sub>L</sub> = 50 pF, R <sub>L</sub> = 110 Ω. V <sub>CC</sub> = 5.0 V, C <sub>L</sub> = 45 pF, R <sub>L</sub> = 667 Ω.
t <sub>PHZ1</sub> t <sub>PHZ1</sub>	Propagation Delay /Data-Output Output High-Low	2.0 —	35 18	2.0 —	46 41	2.0 —	46 41	ns	V <sub>CC</sub> = 5.0 V, C <sub>L</sub> = 50 pF, R <sub>L</sub> = 110 Ω. V <sub>CC</sub> = 5.0 V, C <sub>L</sub> = 45 pF, R <sub>L</sub> = 667 Ω.
t <sub>PZL1</sub> t <sub>PZL1</sub>	Propagation Delay /Data-Output Output Low-High	2.0 —	35 30	2.0 —	46 41	2.0 —	46 41	ns	V <sub>CC</sub> = 5.0 V, C <sub>L</sub> = 50 pF, R <sub>L</sub> = 110 Ω. V <sub>CC</sub> = 5.0 V, C <sub>L</sub> = 45 pF, R <sub>L</sub> = 667 Ω.
t <sub>PZH1</sub> t <sub>PZH1</sub>	Propagation Delay /Data-Output Output High-Low	2.0 —	28 23	2.0 —	36 31	2.0 —	36 31	ns	V <sub>CC</sub> = 5.0 V, C <sub>L</sub> = 50 pF, R <sub>L</sub> = 110 Ω. V <sub>CC</sub> = 5.0 V, C <sub>L</sub> = 45 pF, R <sub>L</sub> = 667 Ω.

## NOTES:

- R<sub>L</sub> = 110 Ω ± 5.0%
- All diodes are 1N3064 or equivalent.
- C<sub>L</sub> = 50 pF ± 10% including probe and jig capacitance.
- The pulse generators have the following characteristics:  
V<sub>gen</sub> = 3.0 V, PRR ≤ 1.0 MHz, t<sub>r</sub> ≤ 15 ns, t<sub>f</sub> = 6.0 ns, Z<sub>OUT</sub> = 50 Ω.
- Clock pulse characteristics: t<sub>p</sub>(clock) = 20 ns, t<sub>setup</sub> = 20 ns.
- The diode and resistor shown within the dotted area are optional. When the diode and resistor are used, V<sub>BIAS</sub> shall be 5.5 V for all tests except for t<sub>PHZ</sub>, for t<sub>PHZ</sub> tests. V<sub>BIAS</sub> shall be - 0.6 V.