

Features

- Guard Ring Die Construction for Transient Protection
- Ideally Suited for Automatic Assembly
- Low Power Loss, High Efficiency
- Surge Overload Rating to 175A Peak
- For Use in Low Voltage, High Frequency Inverters, Free Wheeling, and Polarity Protection Application
- Plastic Material - UL Flammability Classification 94V-0

Mechanical Data

- Case: Molded Plastic
- Terminals: Solder Plated Terminal Solderable per MIL-STD-202, Method 208
- Polarity: Cathode Band or Cathode Notch
- Approx. Weight: 0.21grams
- Marking: Type Number

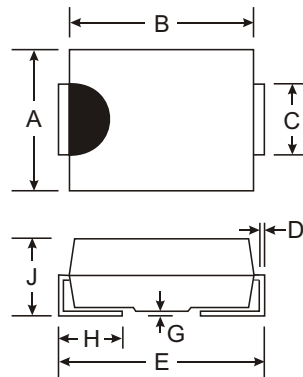

SMC		
Dim	Min	Max
A	5.59	6.22
B	6.60	7.11
C	2.75	3.18
D	0.15	0.31
E	7.75	8.13
G	0.10	0.20
H	0.76	1.52
J	2.00	2.62
All Dimensions in mm		

Maximum Ratings and Electrical Characteristics @ T_A = 25°C unless otherwise specified

Single phase, half wave, 60Hz, resistive or inductive load.
For capacitive load, derate current by 20%.

Characteristic	Symbol	B520C	B530C	B540C	B550C	B560C	Unit
Peak Repetitive Reverse Voltage Working Peak Reverse Voltage DC Blocking Voltage	V_{RRM} V_{RWM} V_R	20	30	40	50	60	V
RMS Reverse Voltage	$V_{R(RMS)}$	14	21	28	35	42	V
Average Rectified Output Current @ T _T = 90°C	I _O	5.0					A
Non-Repetitive Peak Forward Surge Current, 8.3 ms single half-sine-wave Superimposed on Rated Load (JEDEC method)	I _{FSM}	175					A
Forward Voltage @ I _F = 5.0A DC	V _{FM}	0.55			0.70		V
Peak Reverse Current at Rated DC Blocking Voltage @ T _A = 25°C @ T _A = 100°C	I _{RM}	0.5 20					mA
Typical Junction Capacitance (Note 2)	C _j	300					pF
Typical Thermal Resistance, Junction to Terminal (Note 1)	R _{θJT}	10					K/W
Typical Thermal Resistance, Junction to Ambient	R _{θJA}	50					°C/W
Operating Temperature Range	T _j	-55 to +125					°C
Storage Temperature Range	T _{STG}	-55 to +150					°C

Notes: 1. Thermal Resistance: Junction to terminal, unit mounted on PC board with 5.0 mm² (0.013 mm thick) copper pads as heat sink.
2. Measured at 1.0 MHz and applied reverse voltage of 4.0V DC.

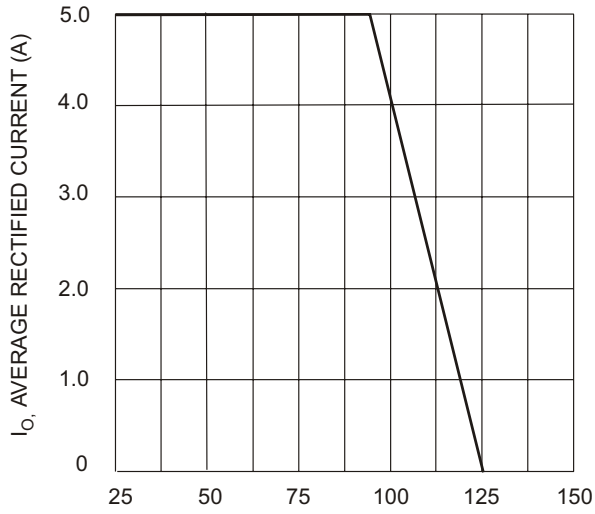

T_T , TERMINAL TEMPERATURE (°C)
 Fig. 1 Forward Current Derating Curve

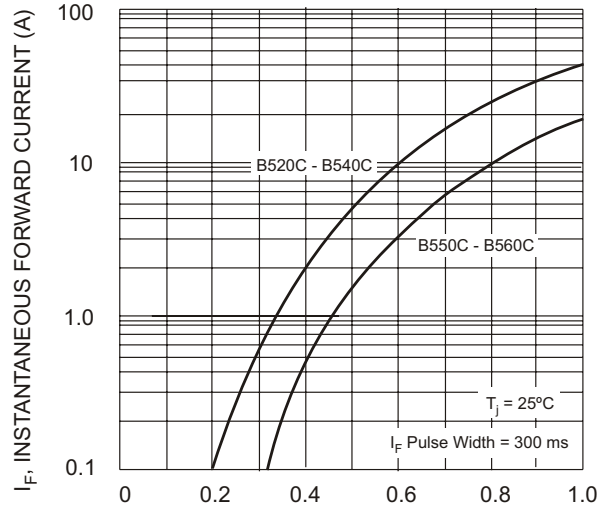

V_F , INSTANTANEOUS FORWARD VOLTAGE (V)
 Fig. 2 Typical Forward Characteristics

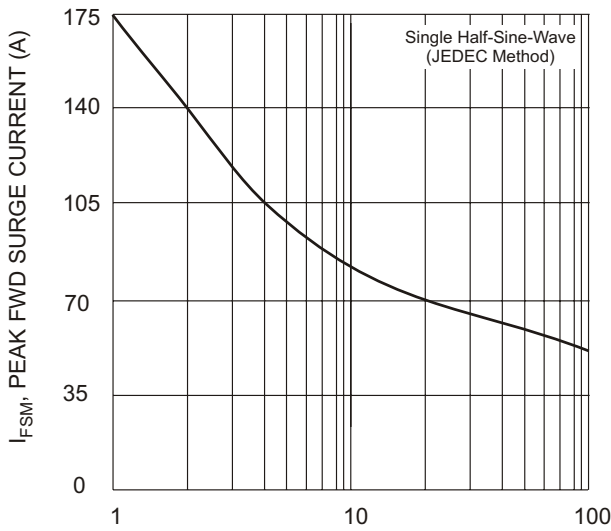
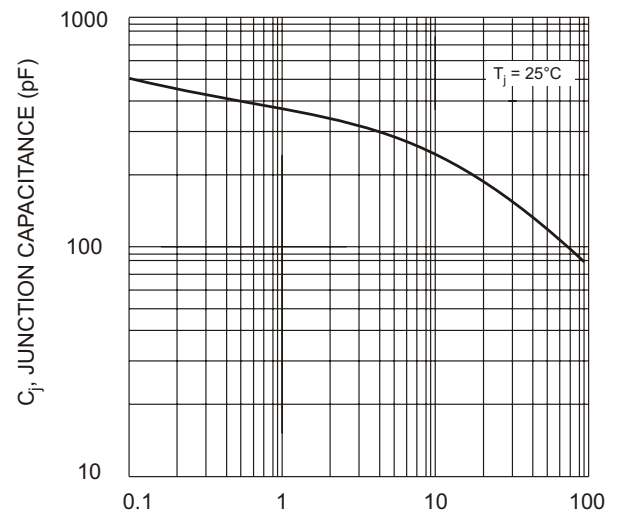

Fig. 3 Max Non-Repetitive Peak Fwd Surge Current



V_R , REVERSE VOLTAGE (V)
 Fig. 4 Typical Junction Capacitance

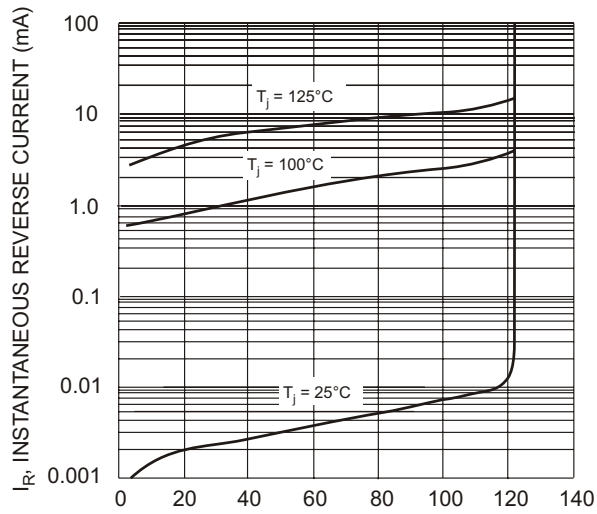

Fig. 5 Typical Reverse Characteristics