

SN54ALS640B, SN54AS640, SN74ALS640B, SN74AS640 OCTAL BUS TRANSCEIVERS WITH 3-STATE OUTPUTS

SDAS122A - DECEMBER 1983 - REVISED JANUARY 1995

- Bidirectional Bus Transceivers in High-Density 20-Pin Packages
- Inverting Logic
- Package Options Include Plastic Small-Outline (DW) Packages, Ceramic Chip Carriers (FK), and Standard Plastic (N) and Ceramic (J) 300-mil DIPs

description

These octal bus transceivers are designed for asynchronous two-way communication between data buses. These devices transmit data from the A bus to the B bus or from the B bus to the A bus, depending upon the level at the direction-control (DIR) input. The output-enable (\overline{OE}) input can be used to disable the device so that the buses are effectively isolated.

The -1 version of the SN74ALS640B is identical to the standard version, except that the recommended maximum I_{OL} for the -1 version is increased to 48 mA. There is no -1 version of the SN54ALS640B.

The SN54ALS640B and SN54AS640 are characterized for operation over the full military temperature range of -55°C to 125°C . The SN74ALS640B and SN74AS640 are characterized for operation from 0°C to 70°C .

SN54ALS640B, SN54AS640... J PACKAGE
SN74ALS640B, SN74AS640... DW OR N PACKAGE
(TOP VIEW)

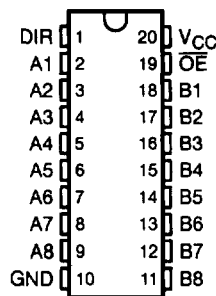

SN54ALS640B, SN54AS640... FK PACKAGE
(TOP VIEW)

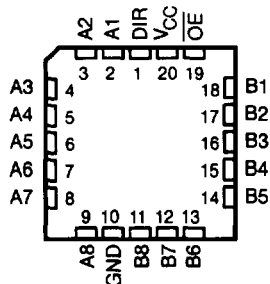

FUNCTION TABLE

INPUTS		OPERATION
\overline{OE}	DIR	
L	L	\overline{B} data to A bus
L	H	\overline{A} data to B bus
H	X	Isolation

PRODUCTION DATA Information is current as of publication date. Products conform to specifications per the terms of Texas Instruments standard warranty. Production processing does not necessarily include testing of all parameters.

 **TEXAS
INSTRUMENTS**

POST OFFICE BOX 655303 • DALLAS, TEXAS 75265

Copyright © 1995, Texas Instruments Incorporated

2-489

SN54ALS640B, SN54AS640, SN74ALS640B, SN74AS640

OCTAL BUS TRANSCEIVERS

WITH 3-STATE OUTPUTS

SDAS122A - DECEMBER 1983 - REVISED JANUARY 1985

logic symbol

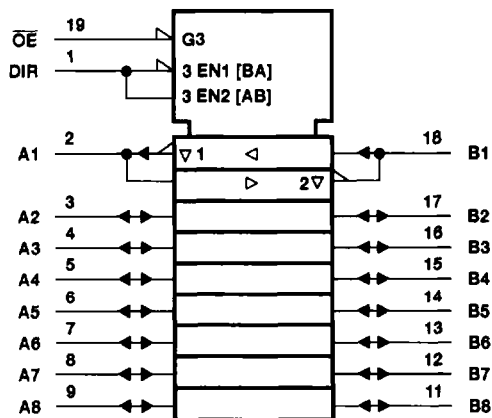

logic diagram (positive logic)

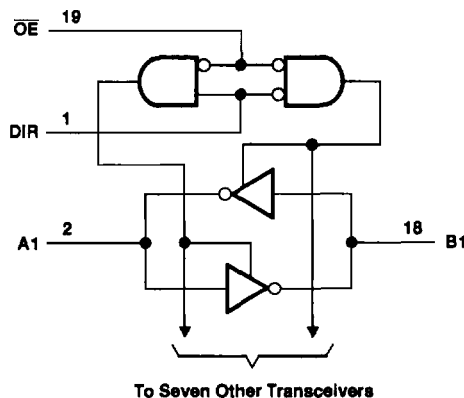

† This symbol is in accordance with ANSI/IEEE Std 91-1984 and IEC Publication 617-12.

absolute maximum ratings over operating free-air temperature range (unless otherwise noted)‡

Supply voltage, V_{CC}	7 V
Input voltage, V_I : All inputs	7 V
I/O ports	5.5 V
Operating free-air temperature range, T_A : SN54ALS640B	-55°C to 125°C
SN74ALS640B	0°C to 70°C
Storage temperature range	-65°C to 150°C

‡ Stresses beyond those listed under "absolute maximum ratings" may cause permanent damage to the device. These are stress ratings only, and functional operation of the device at these or any other conditions beyond those indicated under "recommended operating conditions" is not implied. Exposure to absolute-maximum-rated conditions for extended periods may affect device reliability.

recommended operating conditions

	SN54ALS640B			SN74ALS640B			UNIT
	MIN	NOM	MAX	MIN	NOM	MAX	
V_{CC} Supply voltage	4.5	5	5.5	4.5	5	5.5	V
V_{IH} High-level input voltage	2			2			V
V_{IL} Low-level input voltage			0.7			0.8	V
I_{OH} High-level output current			-12			-15	mA
I_{OL} Low-level output current			12			24	mA
						48§	
T_A Operating free-air temperature	-55		125	0		70	°C

§ Applies only to the -1 version and only if V_{CC} is between 4.75 V and 5.25 V



POST OFFICE BOX 655303 • DALLAS, TEXAS 75265

SN54ALS640B, SN54AS640, SN74ALS640B, SN74AS640

OCTAL BUS TRANSCEIVERS WITH 3-STATE OUTPUTS

SDAS122A - DECEMBER 1983 - REVISED JANUARY 1995

electrical characteristics over recommended operating free-air temperature range (unless otherwise noted)

PARAMETER	TEST CONDITIONS	SN54ALS640B		SN74ALS640B		UNIT	
		MIN	TYP†	MAX	MIN		TYP†
V_{IK}	$V_{CC} = 4.5\text{ V}$, $I_I = -18\text{ mA}$			-1.5		V	
V_{OH}	$V_{CC} = 4.5\text{ V to } 5.5\text{ V}$, $I_{OH} = -0.4\text{ mA}$	$V_{CC} - 2$		$V_{CC} - 2$		V	
	$V_{CC} = 4.5\text{ V}$	$I_{OH} = -3\text{ mA}$		2.4	3.2		
		$I_{OH} = -12\text{ mA}$		2			
		$I_{OH} = -15\text{ mA}$		2			
V_{OL}	$V_{CC} = 4.5\text{ V}$	$I_{OL} = 12\text{ mA}$		0.25	0.4	V	
		$I_{OL} = 24\text{ mA}$		0.35 0.5			
		$I_{OL} = 48\text{ mA}^\ddagger$		0.35 0.5			
I_I	Control inputs	$V_{CC} = 5.5\text{ V}$	$V_I = 7\text{ V}$		0.1		mA
	A or B ports		$V_I = 5.5\text{ V}$		0.1		
I_{IH}	Control inputs	$V_{CC} = 5.5\text{ V}$, $V_I = 2.7\text{ V}$	20		20		μA
	A or B ports§		20		20		
I_{IL}	Control inputs	$V_{CC} = 5.5\text{ V}$, $V_I = 0.4\text{ V}$	-0.1		-0.1		mA
	A or B ports§		-0.1		-0.1		
I_O^∇	$V_{CC} = 5.5\text{ V}$, $V_O = 2.25\text{ V}$	-20 -112		-30 -112		mA	
I_{CC}	$V_{CC} = 5.5\text{ V}$	Outputs high		19	50	19 45	mA
		Outputs low		27	60	27 55	
		Outputs disabled		28	55	28 50	

† All typical values are at $V_{CC} = 5\text{ V}$, $T_A = 25^\circ\text{C}$.

‡ Applies only to the -1 version and only if V_{CC} is between 4.75 V and 5.25 V

§ For I/O ports, the parameters I_{IH} and I_{IL} include the off-state output current.

¶ The output conditions have been chosen to produce a current that closely approximates one half of the true short-circuit output current, I_{OS} .

switching characteristics (see Figure 1)

PARAMETER	FROM (INPUT)	TO (OUTPUT)	$V_{CC} = 4.5\text{ V to } 5.5\text{ V}$, $C_L = 50\text{ pF}$, $R_1 = 500\ \Omega$, $R_2 = 500\ \Omega$, $T_A = \text{MIN to MAX}^\#$				UNIT
			SN54ALS640B		SN74ALS640B		
			MIN	MAX	MIN	MAX	
t_{PLH}	A or B	B or A	2	14	2	11	ns
t_{PHL}			2	13	2	10	
t_{PZH}	\overline{OE}	A or B	4	25	4	21	ns
t_{PZL}			5	27	5	24	
t_{PHZ}	\overline{OE}	A or B	2	12	2	10	ns
t_{PLZ}			3	20	3	15	

For conditions shown as MIN or MAX, use the appropriate value specified under recommended operating conditions.



POST OFFICE BOX 665303 • DALLAS, TEXAS 75266

SN54ALS640B, SN54AS640, SN74ALS640B, SN74AS640

OCTAL BUS TRANSCEIVERS

WITH 3-STATE OUTPUTS

SDAS122A - DECEMBER 1983 - REVISED JANUARY 1995

absolute maximum ratings over operating free-air temperature range (unless otherwise noted)[†]

Supply voltage, V_{CC}	7 V
Input voltage, V_I : All inputs	7 V
I/O ports	5.5 V
Operating free-air temperature range, T_A : SN54AS640	-55°C to 125°C
SN74AS640	0°C to 70°C
Storage temperature range	-65°C to 150°C

[†] Stresses beyond those listed under "absolute maximum ratings" may cause permanent damage to the device. These are stress ratings only, and functional operation of the device at these or any other conditions beyond those indicated under "recommended operating conditions" is not implied. Exposure to absolute-maximum-rated conditions for extended periods may affect device reliability.

recommended operating conditions

	SN54AS640			SN74AS640			UNIT
	MIN	NOM	MAX	MIN	NOM	MAX	
V_{CC} Supply voltage	4.5	5	5.5	4.5	5	5.5	V
V_{IH} High-level input voltage	2			2			V
V_{IL} Low-level input voltage			0.8			0.8	V
I_{OH} High-level output current			-12			-15	mA
I_{OL} Low-level output current			48			64	mA
T_A Operating free-air temperature	-55		125	0		70	°C

electrical characteristics over recommended operating free-air temperature range (unless otherwise noted)

PARAMETER	TEST CONDITIONS	SN54AS640			SN74AS640			UNIT
		MIN	TYP [‡]	MAX	MIN	TYP [‡]	MAX	
V_{IK}	$V_{CC} = 4.5$ V, $I_I = -18$ mA			-1.2			-1.2	V
V_{OH}	$V_{CC} = 4.5$ V, $I_{OH} = -2$ mA	$V_{CC} - 2$						V
	$V_{CC} = 4.5$ V to 5.5 V, $I_{OH} = -2$ mA				$V_{CC} - 2$			
	$V_{CC} = 4.5$ V	$I_{OH} = -3$ mA	2.4	3.2	2.4	3.2		
		$I_{OH} = -12$ mA	2.4					
						2.4		
V_{OL}	$V_{CC} = 4.5$ V	$I_{OL} = 48$ mA		0.3	0.55			V
		$I_{OL} = 64$ mA			0.35	0.55		
I_I	Control inputs	$V_{CC} = 5.5$ V	$V_I = 7$ V			0.1	0.1	mA
	A or B ports		$V_I = 5.5$ V			0.1	0.1	
I_{IH}	Control inputs	$V_{CC} = 5.5$ V,	$V_I = 2.7$ V			20	20	μ A
	A or B ports [§]					70	70	
I_{IL}	Control inputs	$V_{CC} = 5.5$ V,	$V_I = 0.4$ V			-0.5	-0.5	mA
	A or B ports [§]					-0.75	-0.75	
I_O^{\parallel}	$V_{CC} = 5.5$ V, $V_O = 2.25$ V			-50	-150	-50	-150	mA
I_{CC}	$V_{CC} = 5.5$ V	Outputs high		37	58	37	58	mA
		Outputs low		78	123	78	123	
		Outputs disabled		51	80	51	80	

[‡] All typical values are at $V_{CC} = 5$ V, $T_A = 25^\circ$ C.

[§] For I/O ports, the parameters I_{IH} and I_{IL} include the off-state output current.

^{||} The output conditions have been chosen to produce a current that closely approximates one half of the true short-circuit output current, I_{OS} .



POST OFFICE BOX 655303 • DALLAS, TEXAS 75265

SN54ALS640B, SN54AS640, SN74ALS640B, SN74AS640
OCTAL BUS TRANSCEIVERS
WITH 3-STATE OUTPUTS

SDAS122A - DECEMBER 1983 - REVISED JANUARY 1995

switching characteristics (see Figure 1)

PARAMETER	FROM (INPUT)	TO (OUTPUT)	$V_{CC} = 4.5\text{ V to }5.5\text{ V,}$ $C_L = 50\text{ pF,}$ $R_1 = 500\ \Omega,$ $R_2 = 500\ \Omega,$ $T_A = \text{MIN to MAX}^\dagger$				UNIT
			SN54AS640		SN74AS640		
			MIN	MAX	MIN	MAX	
t_{PLH}	A or B	B or A	1	8	2	7	ns
t_{PHL}			1	7	2	6	
t_{PZH}	\overline{OE}	A or B	2	10	2	8	ns
t_{PZL}			2	12	2	10	
t_{PHZ}	\overline{OE}	A or B	2	9	2	8	ns
t_{PLZ}			2	18	2	13	

[†] For conditions shown as MIN or MAX, use the appropriate value specified under recommended operating conditions.



SN54ALS640B, SN54AS640, SN74ALS640B, SN74AS640
OCTAL BUS TRANSCEIVERS
WITH 3-STATE OUTPUTS

SDAS122A - DECEMBER 1983 - REVISED JANUARY 1995

PARAMETER MEASUREMENT INFORMATION
SERIES 54ALS/74ALS AND 54AS/74AS DEVICES

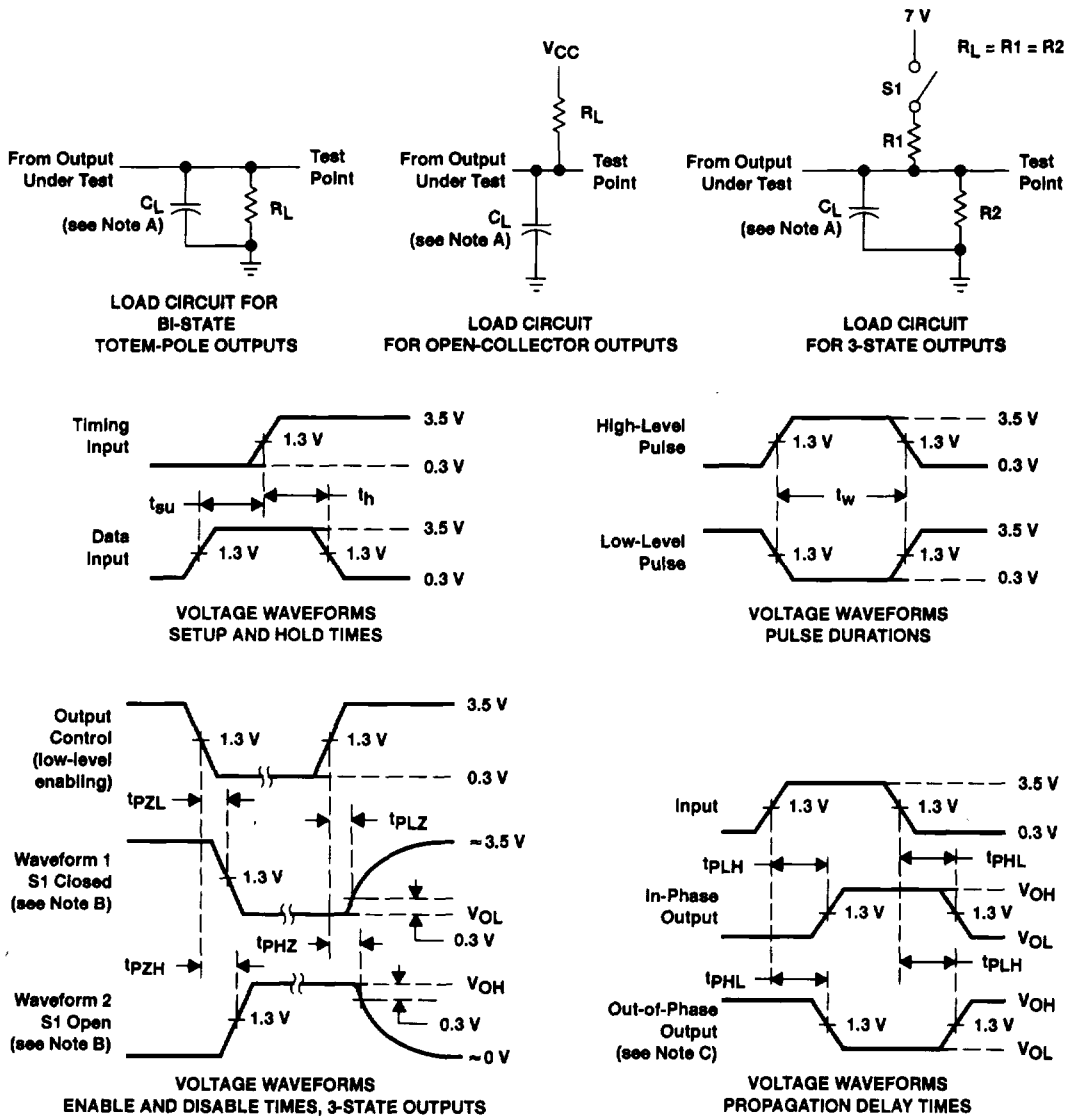

- NOTES: A. C_L includes probe and jig capacitance.
 B. Waveform 1 is for an output with internal conditions such that the output is low except when disabled by the output control. Waveform 2 is for an output with internal conditions such that the output is high except when disabled by the output control.
 C. When measuring propagation delay items of 3-state outputs, switch S1 is open.
 D. All input pulses have the following characteristics: $PRR \leq 1$ MHz, $t_r = t_f = 2$ ns, duty cycle = 50%.
 E. The outputs are measured one at a time with one transition per measurement.

Figure 1. Load Circuits and Voltage Waveforms



POST OFFICE BOX 655303 • DALLAS, TEXAS 75265