

TOROIDAL INDUCTORS

TYPE PS/PF/PSC/PFC—Printed Circuit

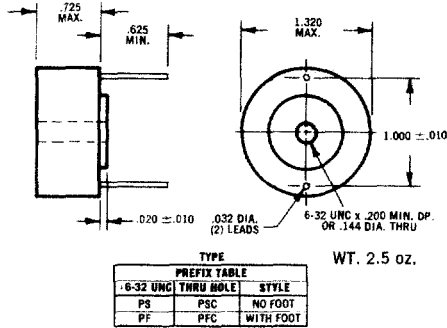

TYPE U — Uncased

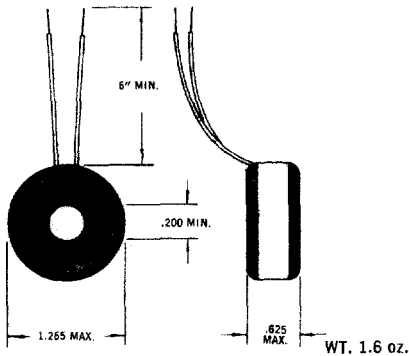

TYPE P — Compression Molded

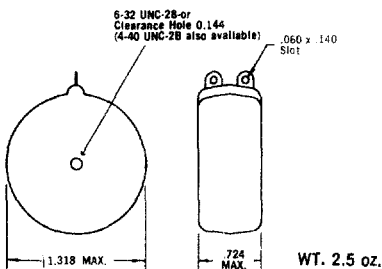

TYPE M — Metal Cased

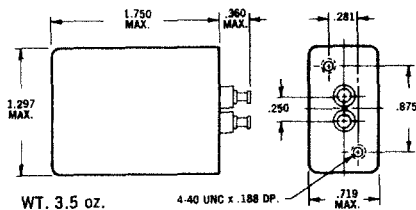

Mechanical Tolerance: $\pm .015$ unless otherwise indicated.
Studs are available on the "M" Series on special request.

CORE NO. 30

Recommended Frequency: Up to 20 KHz.

Maximum Inductance: 17.5 H.

Special Core Stabilization Available:
B, D, L, M, W.

Inductance $\pm 1\%$ (mH)	Part Number	Typical	
		DCR* (ohms)	Distributed Capacity (pf)
5.0	30-1	0.53	63
6.0	30-40	0.63	64
7.2	30-41	0.76	65
7.5	30-2	0.79	66
8.6	30-42	0.90	67
10.0	30-3	1.05	68
12.0	30-43	1.26	69
12.5	30-4	1.31	69
15.0	30-5	1.58	70
17.5	30-44	1.84	71
20.0	30-6	2.10	72
24.0	30-45	2.52	73
25.0	30-7	2.63	73
30.0	30-8	3.15	75
36.0	30-46	3.78	76
40.0	30-9	4.20	77
43.0	30-47	4.52	78
50.0	30-10	5.25	79
60.0	30-48	6.30	80
72.0	30-49	7.56	81
75.0	30-11	7.86	81
86.0	30-50	9.03	82
100.0	30-12	10.50	83
120.0	30-51	12.60	84
125.0	30-13	13.10	84
150.0	30-14	15.80	85
175.0	30-53	18.40	86
200.0	30-15	21.00	87
240.0	30-54	25.20	88
250.0	30-52	26.30	88
300.0	30-16	31.50	89
360.0	30-55	37.80	90
400.0	30-17	42.00	91
430.0	30-56	45.20	92
500.0	30-18	52.50	92
600.0	30-57	63.00	93
720.0	30-58	75.60	94
750.0	30-19	78.70	96
860.0	30-59	90.30	97
1.00 H	30-20	105.00	98
1.20 H	30-60	126.00	99
1.25 H	30-21	131.30	99
1.50 H	30-22	157.50	100
1.75 H	30-61	183.80	101
2.00 H	30-23	210.00	102
2.40 H	30-62	252.00	103
2.50 H	30-69	262.50	103
3.00 H	30-24	315.00	104
3.60 H	30-63	378.00	106
4.00 H	30-25	420.00	107
4.30 H	30-64	451.50	108
5.00 H	30-26	525.00	109
6.00 H	30-65	630.00	110
7.20 H	30-66	756.00	111
7.50 H	30-27	787.50	112
8.60 H	30-67	903.00	113
10.00 H	30-28	1050.00	114
12.00 H	30-68	1260.00	115
12.50 H	30-29	1312.50	116
15.00 H	30-30	1575.00	117
17.50 H	30-31	1837.50	118

* See page 4 for explanation of variations in DC resistance.

CORE NO. 94

Recommended Frequency: Up to 75 KHz.

Maximum Inductance: 1 H.

Special Core Stabilization Available: B, D, M, W, L.

Inductance $\pm 1\%$ (mH)	Part Number	Typical	
		DCR* (ohms)	Distributed Capacity (pf)
5.0	94-1	1.05	32
6.0	94-2	1.26	33
7.2	94-3	1.51	33
7.5	94-4	1.58	34
8.6	94-5	1.80	35
10.0	94-6	2.10	35
12.0	94-7	2.52	36
12.5	94-8	2.63	37
15.0	94-9	3.15	38
17.5	94-10	3.67	39
20.0	94-11	4.20	40
24.0	94-12	5.04	41
25.0	94-13	5.25	41
30.0	94-14	6.30	42
36.0	94-15	7.56	43
40.0	94-16	8.40	44
43.0	94-17	9.03	44
50.0	94-18	10.50	45
60.0	94-19	12.60	46
72.0	94-20	15.10	46
75.0	94-21	15.80	47
86.0	94-22	18.00	47
100.0	94-23	21.00	48
120.0	94-24	25.20	49
125.0	94-25	26.30	49
150.0	94-26	31.50	50
175.0	94-27	36.80	51
200.0	94-28	42.00	52
240.0	94-29	50.40	53
250.0	94-30	52.50	54
300.0	94-31	63.00	54
360.0	94-32	75.60	56
400.0	94-33	84.00	57
430.0	94-34	90.00	57
500.0	94-35	105.00	57
600.0	94-36	126.00	58
720.0	94-37	151.00	58
750.0	94-38	158.00	59
860.0	94-39	181.00	59

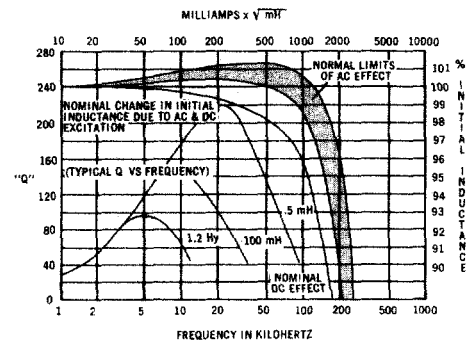
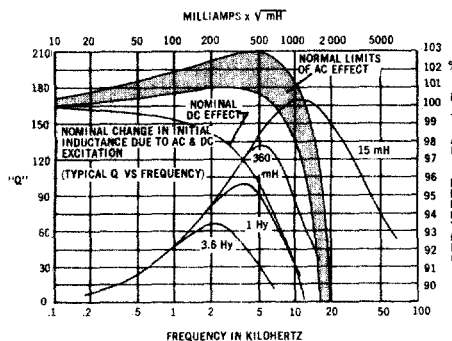

INDUCTORS

TOROTEL PRODUCTS INC./13402 South 71 Highway/Grandview, MO 64030/(816) 761-6314 TWX 910-777-7037

TOROIDAL INDUCTORS

CORE NO. 28

Recommended Frequency: Up to 35 KHz.
Maximum Inductance: 25 H.
Special Core Stabilization: D, W, M, L.

Inductance ±1% (mH)	Part Number	Typical	
		DCR* (ohms)	Distributed Capacity (pf)
7.2	28-1	0.64	60
8.6	28-2	0.70	64
10.0	28-3	0.97	66
12.0	28-4	1.06	68
15.0	28-5	1.19	70
17.5	28-6	1.66	74
20.0	28-7	1.78	76
24.0	28-8	1.95	78
30.0	28-9	2.57	80
36.0	28-10	2.82	84
43.0	28-11	3.86	86
50.0	28-12	4.16	88
60.0	28-13	4.55	90
72.0	28-14	6.33	94
86.0	28-15	6.91	96
100.0	28-16	9.36	98
120.0	28-17	10.30	100
150.0	28-18	11.50	102
175.0	28-19	16.20	104
200.0	28-20	17.30	106
240.0	28-21	18.90	108
300.0	28-22	26.50	110
360.0	28-23	29.00	114
430.0	28-24	31.70	116
500.0	28-25	42.10	118
600.0	28-26	46.20	120
720.0	28-27	64.50	124
860.0	28-28	70.50	126
1.00 H	28-29	93.90	128
1.20 H	28-30	103.00	130
1.50 H	28-31	115.00	134
1.75 H	28-32	154.00	136
2.00 H	28-33	164.00	140
2.40 H	28-34	229.00	144
3.00 H	28-35	256.00	146
3.60 H	28-36	281.00	148
4.30 H	28-37	388.00	150
5.00 H	28-38	419.00	152
6.00 H	28-39	510.00	154
7.20 H	28-40	624.00	156
8.60 H	28-41	682.00	158
10.00 H	28-42	930.00	160
12.00 H	28-43	1020.00	164
15.00 H	28-44	1440.00	166
17.50 H	28-45	1550.00	168
20.00 H	28-46	1660.00	170

CORE NO. 27

Recommended Frequency: Up to 20 KHz.
Maximum Inductance: 30 H.
Special Core Stabilization: D, W, M, L.

Inductance ±1% (mH)	Part Number	Typical	
		DCR* (ohms)	Distributed Capacity (pf)
8.6	27-1	0.63	60
10.0	27-2	0.68	64
12.0	27-3	0.95	66
15.0	27-4	1.06	68
17.5	27-5	1.15	70
20.0	27-6	1.59	74
24.0	27-7	1.74	76
30.0	27-8	1.95	78
36.0	27-9	2.52	80
43.0	27-10	2.76	84
50.0	27-11	2.97	86
60.0	27-12	4.07	88
72.0	27-13	4.46	90
86.0	27-14	6.18	94
100.0	27-15	6.67	96
120.0	27-16	7.30	98
150.0	27-17	10.30	100
175.0	27-18	11.10	102
200.0	27-19	15.50	104
240.0	27-20	16.90	106
300.0	27-21	18.90	108
360.0	27-22	26.00	110
430.0	27-23	28.40	114
500.0	27-24	37.70	116
600.0	27-25	41.30	118
720.0	27-26	45.30	120
860.0	27-27	63.10	124
1.00 H	27-28	68.00	126
1.20 H	27-29	74.50	128
1.50 H	27-30	103.00	130
1.75 H	27-31	111.00	134
2.00 H	27-32	147.00	136
2.40 H	27-33	161.00	140
3.00 H	27-34	229.00	144
3.60 H	27-35	251.00	146
4.30 H	27-36	274.00	148
5.00 H	27-37	374.00	150
6.00 H	27-38	410.00	152
7.20 H	27-39	559.00	154
8.60 H	27-40	611.00	156
10.00 H	27-41	659.00	158
12.00 H	27-42	912.00	160
15.00 H	27-43	1020.00	164
17.50 H	27-44	1390.00	166
20.00 H	27-45	1490.00	168
24.00 H	27-46	1630.00	170

CORE NO. 25

Recommended Frequency: Up to 5 KHz.
Maximum Inductance: 40 H.
Special Core Stabilization: L.

Inductance ±1% (mH)	Part Number	Typical	
		DCR* (ohms)	Distributed Capacity (pf)
12.0	25-1	0.60	80
15.0	25-2	0.67	84
17.5	25-3	0.94	86
20.0	25-4	1.00	88
24.0	25-5	1.10	90
30.0	25-6	1.59	94
36.0	25-7	1.74	96
43.0	25-8	1.91	98
50.0	25-9	2.42	100
60.0	25-10	2.66	104
72.0	25-11	2.91	106
86.0	25-12	3.98	108
100.0	25-13	4.29	110
120.0	25-14	5.96	112
150.0	25-15	6.67	114
175.0	25-16	7.20	116
200.0	25-17	9.67	118
240.0	25-18	10.60	120
300.0	25-19	15.50	124
360.0	25-20	16.90	126
430.0	25-21	18.50	128
500.0	25-22	25.00	130
600.0	25-23	27.40	132
720.0	25-24	30.00	134
860.0	25-25	40.40	136
1.00 H	25-26	43.50	138
1.20 H	25-27	60.80	140
1.50 H	25-28	68.00	144
1.75 H	25-29	73.40	146
2.00 H	25-30	97.00	150
2.40 H	25-31	106.00	154
3.00 H	25-32	147.00	156
3.60 H	25-33	161.00	158
4.30 H	25-34	224.00	160
5.00 H	25-35	241.00	166
6.00 H	25-36	264.00	168
7.20 H	25-37	367.00	170
8.60 H	25-38	401.00	174
10.00 H	25-39	432.00	176
12.00 H	25-40	589.00	178
15.00 H	25-41	658.00	180
17.50 H	25-42	900.00	184
20.00 H	25-43	970.00	186
24.00 H	25-44	1060.00	190
30.00 H	25-45	1490.00	196
36.00 H	25-46	1630.00	200

* See page 4 for explanation of variations in DC resistance.

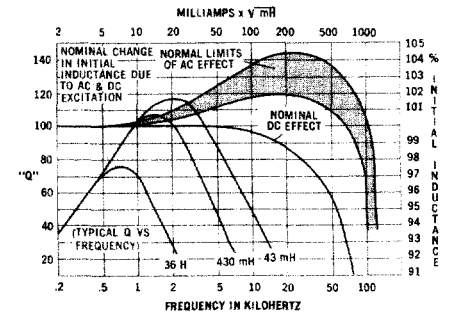
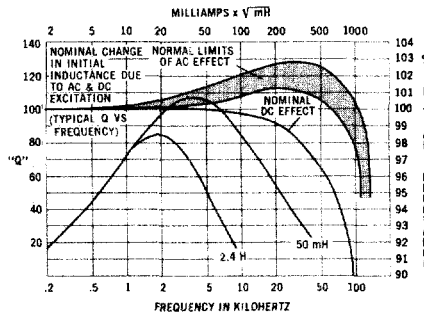
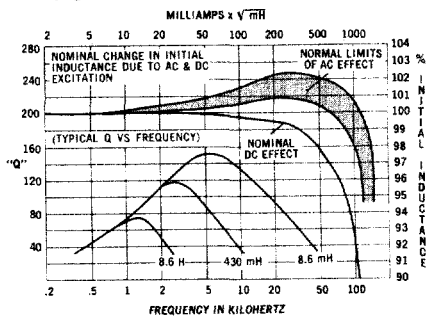

WHEN ORDERING, ADD CASE PREFIX (TYPE) TO PART NUMBER.
EXAMPLE: U 30-1
CASE TYPE ——— PART NUMBER
SEE PAGE 5 FOR SPECIAL ORDERING

† Add "C" to part number of molded inductor if clearance hole is desired.