



Precision Monolithic Quad SPST CMOS Analog Switches

FEATURES

- 44-V Supply Max Rating
- ±15-V Analog Signal Range
- On-Resistance— $r_{DS(on)}$: 25 Ω
- Fast Switching— t_{ON} : 68 ns
- Ultra Low Power— P_D : 0.35 μ W
- TTL, CMOS Compatible
- Single Supply Capability

BENEFITS

- Widest Dynamic Range
- Low Signal Errors and Distortion
- Break-Before-Make Switching Action
- Simple Interfacing

APPLICATIONS

- Precision Automatic Test Equipment
- Precision Data Acquisition
- Communication Systems
- Battery Powered Systems
- Computer Peripherals

DESCRIPTION

The DG411HS series of monolithic quad analog switches was designed to provide high speed, low error switching of precision analog signals. Combining low power (0.35 μ W) with high speed (t_{ON} : 68 ns), the DG411HS family is ideally suited for portable and battery powered industrial and military applications.

Each switch conducts equally well in both directions when on, and blocks input voltages up to the supply levels when off.

The DG411HS and DG412HS respond to opposite control logic as shown in the Truth Table. The DG413HS has two normally open and two normally closed switches.

To achieve high-voltage ratings and superior switching performance, the DG411HS series was built on Vishay Siliconix's high voltage silicon gate process. An epitaxial layer prevents latchup.

FUNCTIONAL BLOCK DIAGRAM AND PIN CONFIGURATION

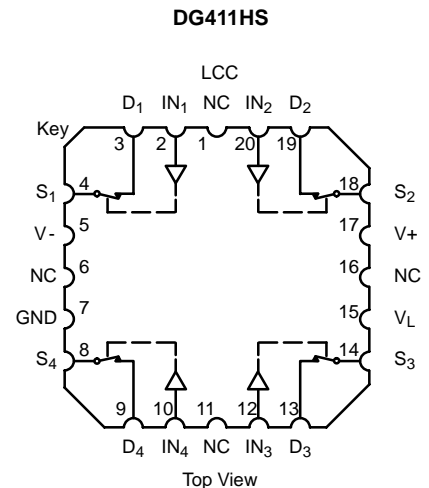
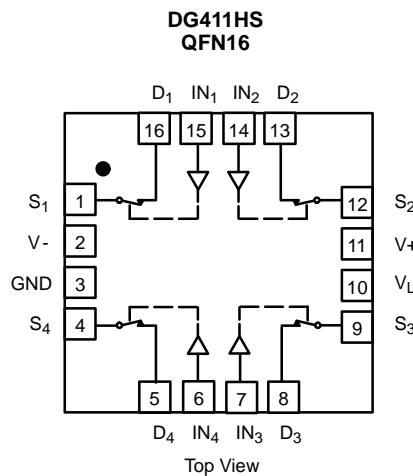
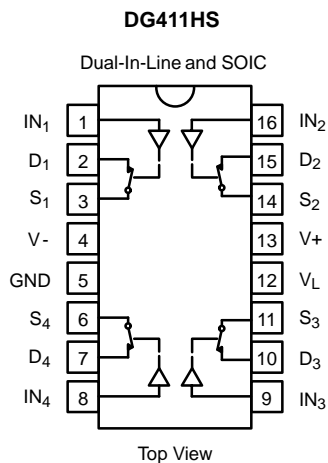

TRUTH TABLE		
Logic	DG411HS	DG412HS
0	ON	OFF
1	OFF	ON



FUNCTIONAL BLOCK DIAGRAM AND PIN CONFIGURATION

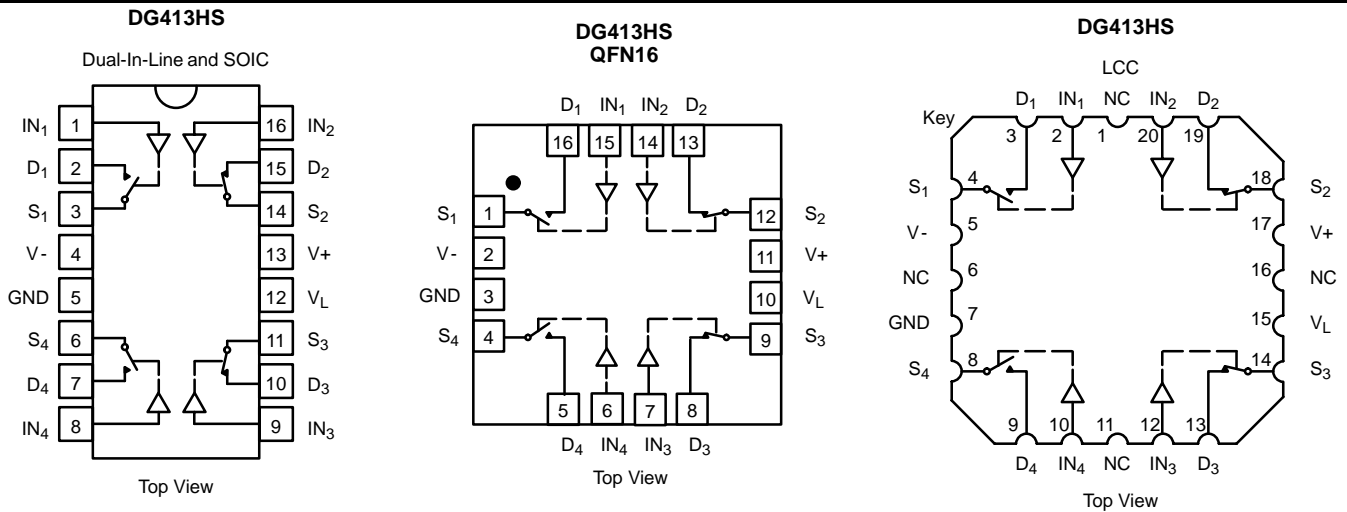

TRUTH TABLE		
Logic	SW ₁ , SW ₄	SW ₂ , SW ₃
0	OFF	ON
1	ON	OFF

ORDERING INFORMATION		
Temp Range	Package	Part Number
DG411HS/412HS		
-40 to 85°C	16-Pin Plastic DIP	DG411HSDJ
		DG412HSDJ
	16-Pin Narrow SOIC	DG411HSDY
		DG412HSDY
16-Pin QFN 4x4mm	DG411HSDN	
	DG412HSDN	
-55 to 125°C	16-Pin CerDIP	DG411HSAK, DG411HSAK/883
		DG412HSAK, DG412HSAK/883
	LCC-20	DG411HSAZ/883
DG413HS		
-40 to 85°C	16-Pin Plastic DIP	DG413HSDJ
	16-Pin Narrow SOIC	DG413HSDY
	16-Pin QFN 4x4mm	DG413HSDN
-55 to 125°C	16-Pin CerDIP	DG413HSAK, DG413HSAK/883
	LCC-20	



ABSOLUTE MAXIMUM RATINGS

V+ to V-	44 V
GND to V-	25 V
V _L	(GND -0.3 V) to (V+) +0.3 V
Digital Inputs ^a , V _S , V _D	(V-) -2 V to (V+) +2 V or 30 mA, whichever occurs first
Continuous Current (Any Terminal)	30 mA
Peak Current, S or D (Pulsed 1 ms, 10% Duty Cycle)	100 mA
Storage Temperature (AK, AZ Suffix)	-65 to 150°C
(DJ, DY, DN Suffix)	-65 to 125°C
Power Dissipation (Package) ^b	
16-Pin Plastic DIP ^c	470 mW

16-Pin Narrow SOIC ^d	600 mW
16-Pin CerDIP ^e	900 mW
LCC-20 ^e	900 mW
16-Pin (4x4mm) QFN ^f	1880 mW

Notes:

- a. Signals on S_X, D_X, or IN_X exceeding V+ or V- will be clamped by internal diodes. Limit forward diode current to maximum current ratings.
- b. All leads welded or soldered to PC Board.
- c. Derate 6 mW/°C above 25°C
- d. Derate 7.6 mW/°C above 75°C
- e. Derate 12 mW/°C above 75°C
- f. Derate 23.5 mW/°C above 70°C

SPECIFICATIONS^a

Parameter	Symbol	Test Conditions Unless Specified V+ = 15 V, V- = -15 V V _L = 5 V, V _{IN} = 2.4 V, 0.8 V ^f	Temp ^b	Typ ^c	A Suffix -55 to 125°C		D Suffix -40 to 85°C		Unit
					Min ^d	Max ^d	Min ^d	Max ^d	
Analog Switch									
Analog Signal Range ^e	V _{ANALOG}		Full		-15	15	-15	15	V
Drain-Source On-Resistance	r _{DS(on)}	V+ = 13.5 V, V- = -13.5 V I _S = -10 mA, V _D = ±8.5 V	Room Full	25		35 45		35 45	Ω
Switch Off Leakage Current	I _{S(off)}	V+ = 16.5 V, V- = -16.5 V V _D = ±15.5 V, V _S = ±15.5 V	Room Full	±0.1	-0.25 -20	0.25 20	-0.25 -5	0.25 5	nA
	I _{D(off)}		Room Full	±0.1	-0.25 -20	0.25 20	-0.25 -5	0.25 5	
Channel On Leakage Current	I _{D(on)}	V+ = 16.5 V, V- = -16.5 V V _S = V _D = ±15.5 V	Room Full	±0.1	-0.4 -40	0.4 40	-0.4 -10	0.4 10	
Digital Control									
Input Current, V _{IN} Low	I _{IL}	V _{IN} Under Test = 0.8 V	Full	0.005	-0.5	0.5	-0.5	0.5	μA
Input Current, V _{IN} High	I _{IH}	V _{IN} Under Test = 2.4 V	Full	0.005	-0.5	0.5	-0.5	0.5	μA
Input Capacitance ^e	C _{IN}	f = 1 MHz	Room	5					pF
Dynamic Characteristics									
Turn-On Time	t _{ON}	R _L = 300 Ω, C _L = 35 pF V _S = ±10 V See Figure 2	Room Full	68		105 127		105 116	ns
Turn-Off Time	t _{OFF}		Room Full	42		80 94		80 90	
Break-Before-Make Time Delay	t _D	DG413HS Only, V _S = 10 V R _L = 300 Ω, C _L = 35 pF	Room	20					
Charge Injection	Q	V _g = 0 V, R _g = 0 Ω, C _L = 1 nF	Room	22					pC
Off Isolation ^e	OIRR	R _L = 50 Ω, C _L = 5 pF, f = 1 MHz	Room	-91					dB
Channel-to-Channel Cross-talk ^e	X _{TALK}		Room	-88					
Source Off Capacitance ^e	C _{S(off)}	f = 1 MHz	Room	12					pF
Drain Off Capacitance ^e	C _{D(off)}		Room	12					
Channel On Capacitance ^e	C _{D(on)}		Room	30					
Power Supplies									
Positive Supply Current	I+	V+ = 16.5 V, V- = -16.5 V V _{IN} = 0 or 5 V	Room Full	0.0001		1 5		1 5	μA
Negative Supply Current	I-		Room Full	-0.0001	-1 -5		-1 -5		
Logic Supply Current	I _L		Room Full	0.0001		1 5		1 5	
Ground Current	I _{GND}		Room Full	-0.0001	-1 -5		-1 -5		



SPECIFICATIONS ^a FOR UNIPOLAR SUPPLIES									
Parameter	Symbol	Test Conditions Unless Specified $V_+ = 12\text{ V}, V_- = 0\text{ V}$ $V_L = 5\text{ V}, V_{IN} = 2.4\text{ V}, 0.8\text{ V}^f$	Temp ^b	Typ ^c	A Suffix -55 to 125°C		D Suffix -40 to 85°C		Unit
					Min ^d	Max ^d	Min ^d	Max ^d	
Analog Switch									
Analog Signal Range ^e	V_{ANALOG}		Full			12		12	V
Drain-Source On-Resistance	$r_{DS(on)}$	$V_+ = 10.8\text{ V}, I_S = -10\text{ mA}$ $V_D = 3\text{ V}, 8\text{ V}$	Room Full	49		80 100		80 100	Ω
Dynamic Characteristics									
Turn-On Time	t_{ON}	$R_L = 300\ \Omega, C_L = 35\text{ pF}$ $V_S = 8\text{ V}, \text{ See Figure 2}$	Room Hot	95		140 180		140 160	ns
Turn-Off Time	t_{OFF}		Room Hot	36		70 79		70 74	
Break-Before-Make Time Delay	t_D	DG413HS Only, $V_S = 8\text{ V}$, $R_L = 300\ \Omega, C_L = 35\text{ pF}$	Room	60					
Charge Injection	Q	$V_g = 6\text{ V}, R_g = 0\ \Omega, C_L = 1\text{ nF}$	Room	60					pC
Power Supplies									
Positive Supply Current	I_+	$V_+ = 13.2, V_{IN} = 0\text{ or }5\text{ V}$	Room Hot	0.0001		1 5		1 5	μA
Negative Supply Current	I_-		Room Hot	-0.0001	-1 -5		-1 -5		
Logic Supply Current	I_L		Room Hot	0.0001		1 5		1 5	
Ground Current	I_{GND}		Room Hot	-0.0001	-1 -5		-1 -5		

Notes:

- Refer to PROCESS OPTION FLOWCHART.
- Room = 25°C, Full = as determined by the operating temperature suffix.
- Typical values are for DESIGN AID ONLY, not guaranteed nor subject to production testing.
- The algebraic convention whereby the most negative value is a minimum and the most positive a maximum, is used in this data sheet.
- Guaranteed by design, not subject to production test.
- V_{IN} = input voltage to perform proper function.

TYPICAL CHARACTERISTICS (25°C UNLESS NOTED)

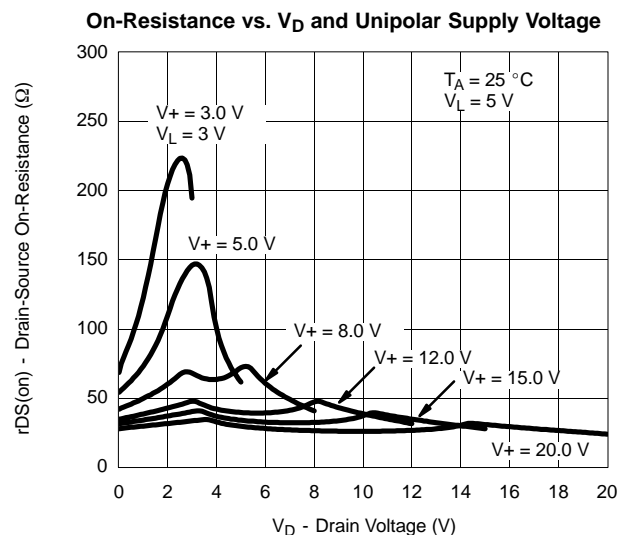
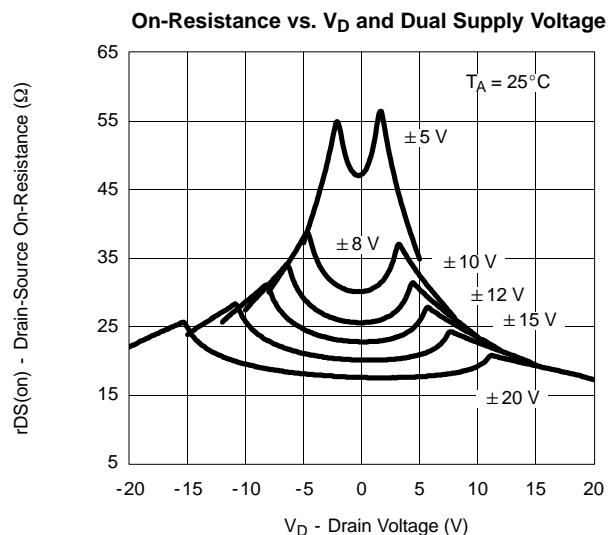



TYPICAL CHARACTERISTICS (25°C UNLESS NOTED)

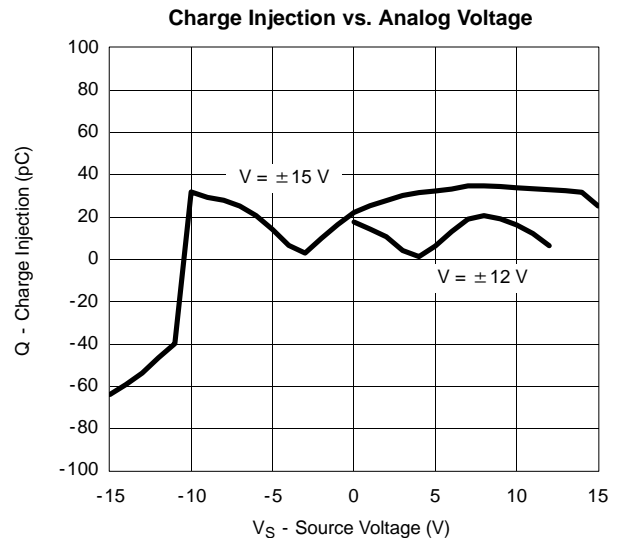
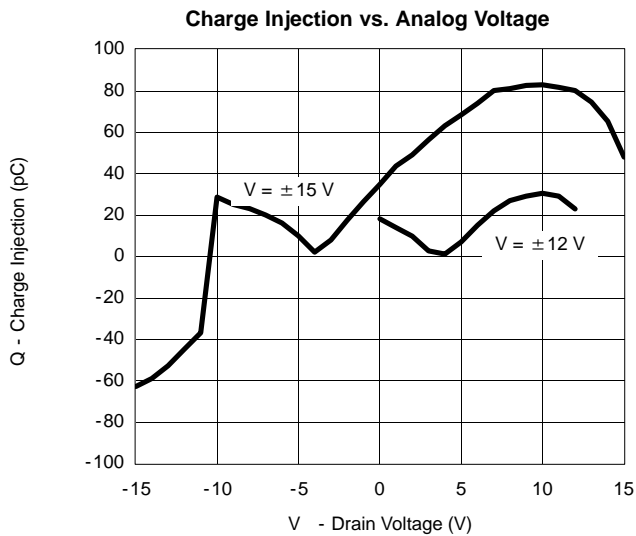
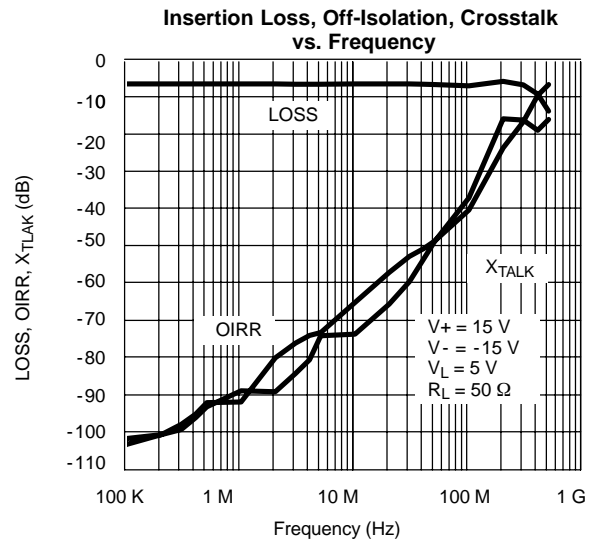
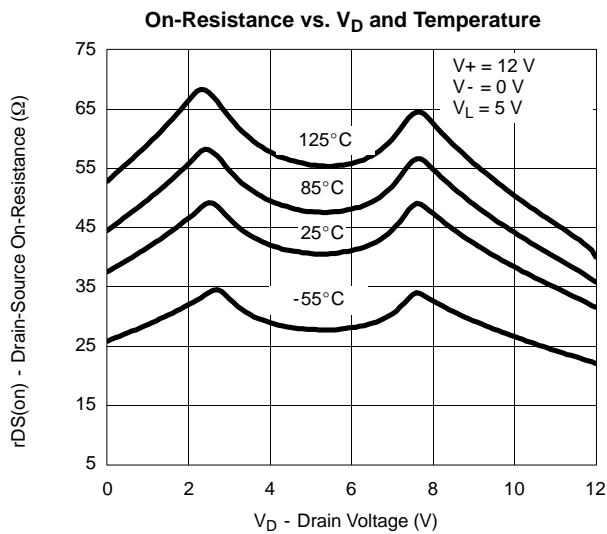
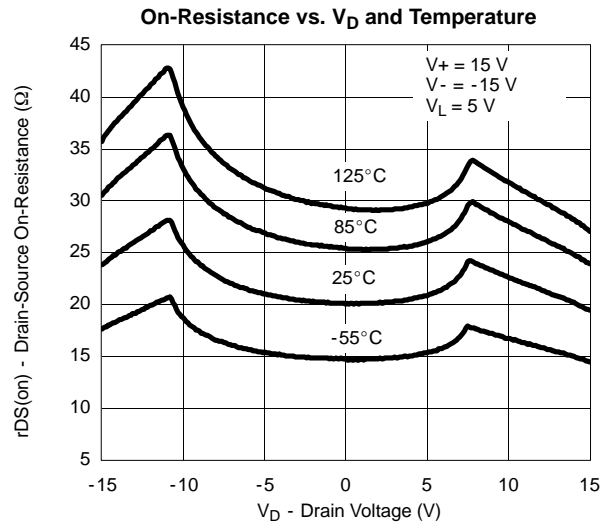
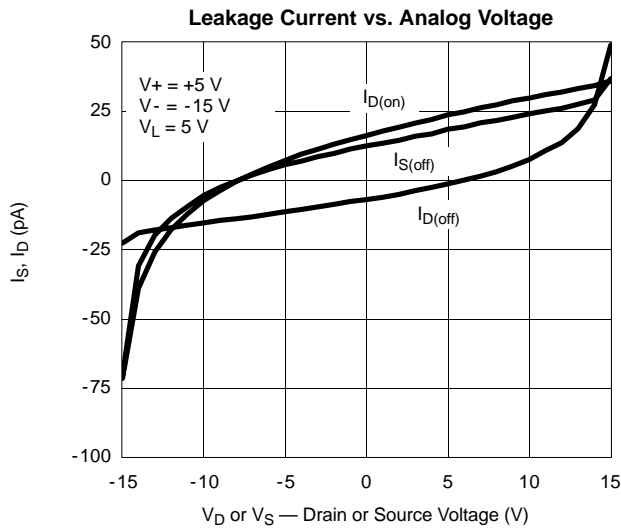



TYPICAL CHARACTERISTICS (25°C UNLESS NOTED)

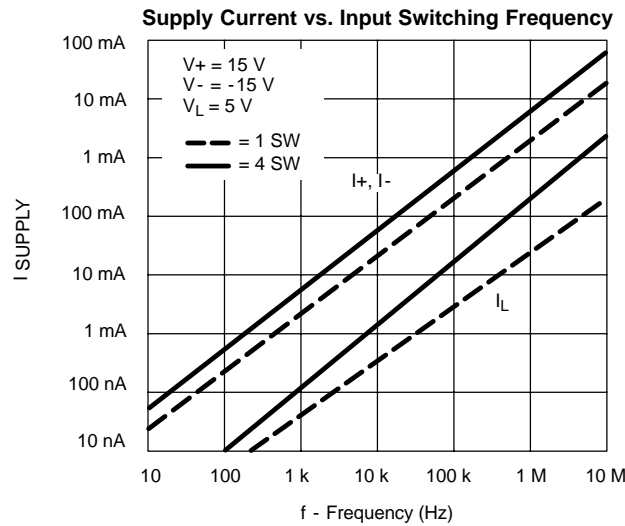
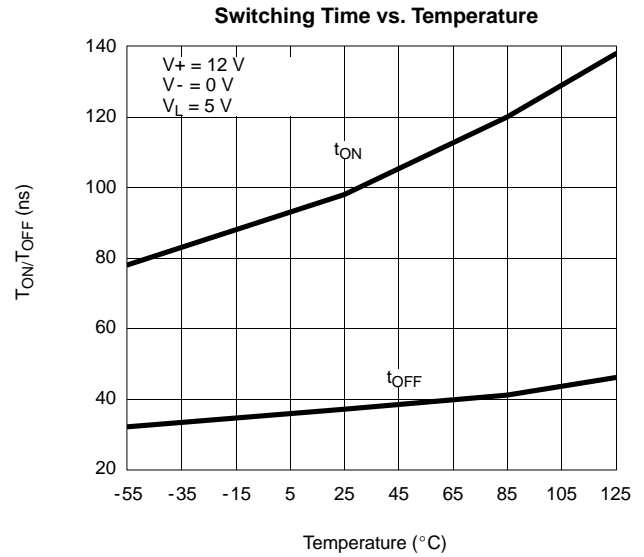
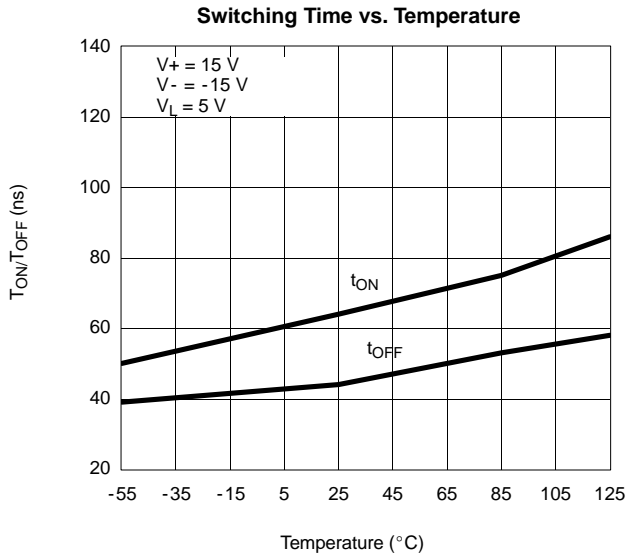

SCHEMATIC DIAGRAM (TYPICAL CHANNEL)

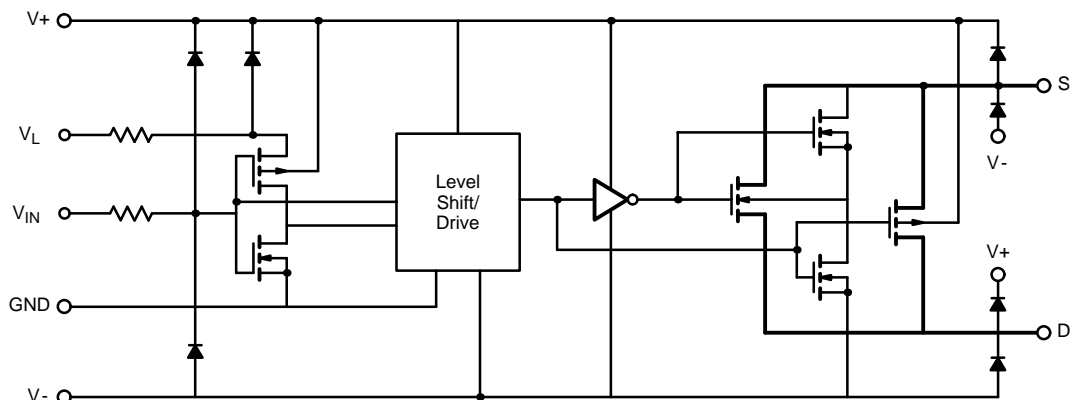
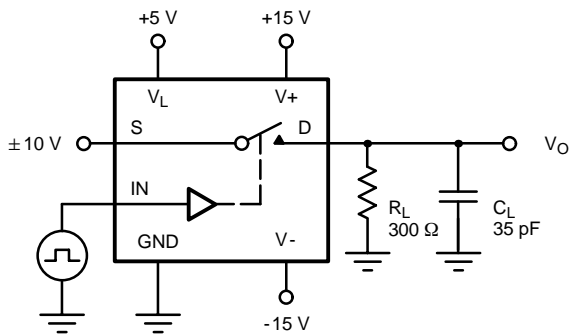

FIGURE 1.

TEST CIRCUITS



C_L (includes fixture and stray capacitance)

$$V_O = V_S \frac{R_L}{R_L + r_{DS(on)}}$$

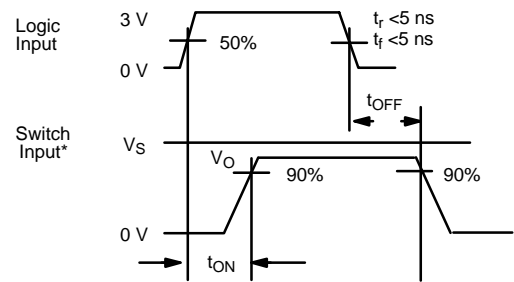

Note: Logic input waveform is inverted for switches that have the opposite logic sense control

FIGURE 2. Switching Time

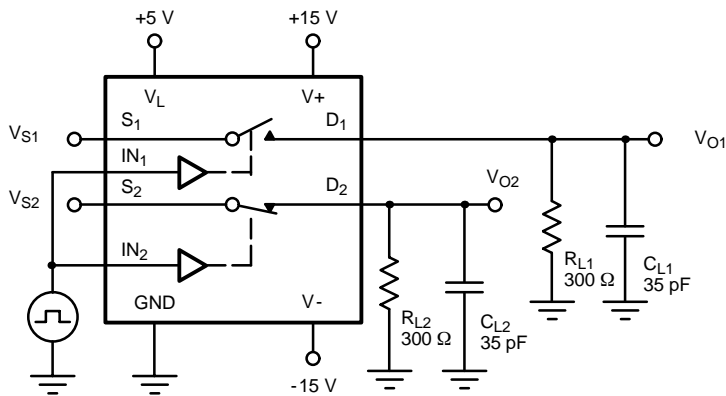

C_L (includes fixture and stray capacitance)

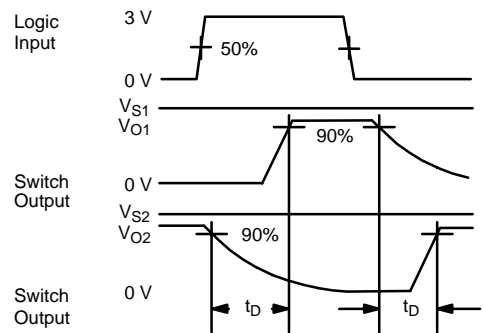

FIGURE 3. Break-Before-Make (DG413HS)

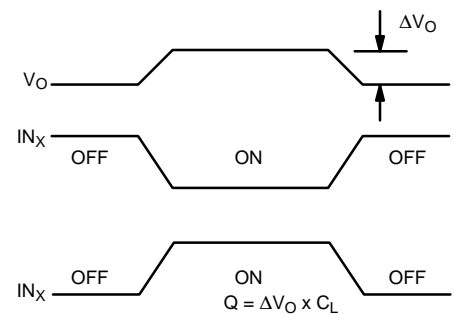
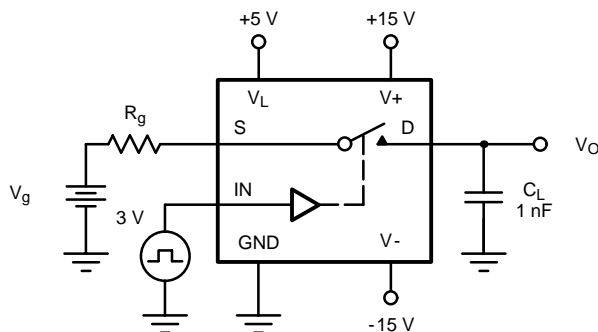

FIGURE 4. Charge Injection

TEST CIRCUITS

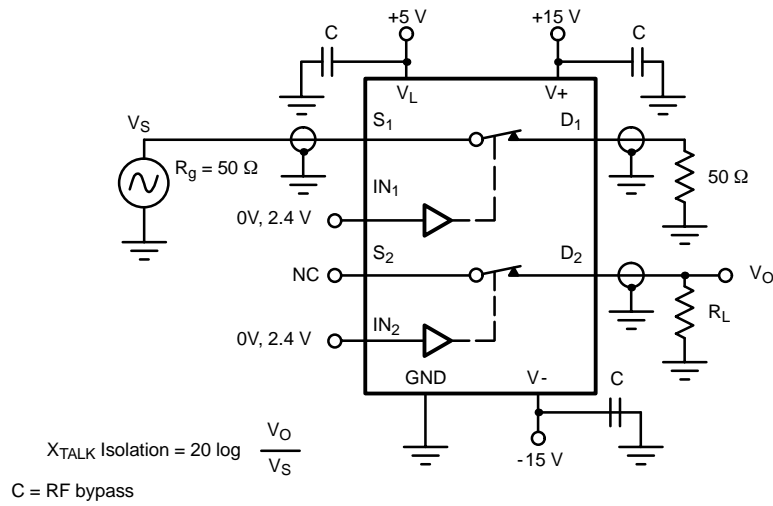

FIGURE 5. Crosstalk

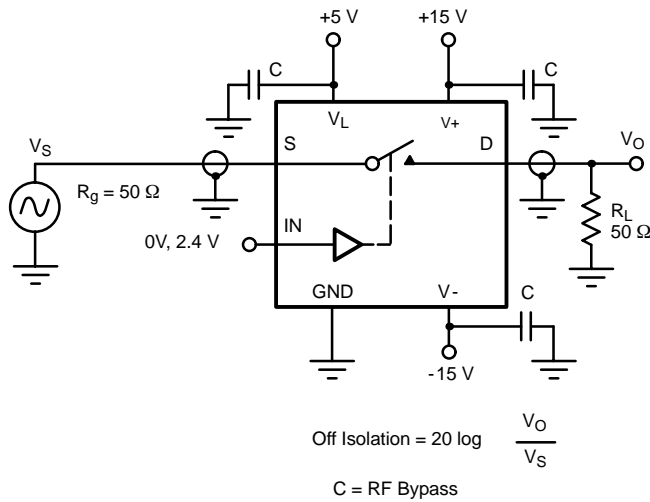

FIGURE 6. Off Isolation

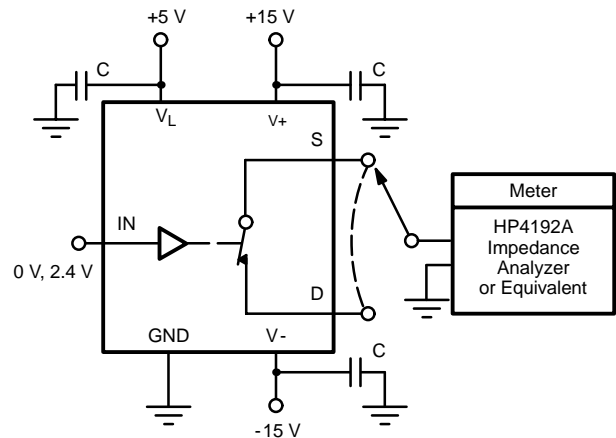

FIGURE 7. Source/Drain Capacitances



Notice

Specifications of the products displayed herein are subject to change without notice. Vishay Intertechnology, Inc., or anyone on its behalf, assumes no responsibility or liability for any errors or inaccuracies.

Information contained herein is intended to provide a product description only. No license, express or implied, by estoppel or otherwise, to any intellectual property rights is granted by this document. Except as provided in Vishay's terms and conditions of sale for such products, Vishay assumes no liability whatsoever, and disclaims any express or implied warranty, relating to sale and/or use of Vishay products including liability or warranties relating to fitness for a particular purpose, merchantability, or infringement of any patent, copyright, or other intellectual property right.

The products shown herein are not designed for use in medical, life-saving, or life-sustaining applications. Customers using or selling these products for use in such applications do so at their own risk and agree to fully indemnify Vishay for any damages resulting from such improper use or sale.