

512Kx8 Monolithic SRAM, SMD 5962-95600

FEATURES

- Access Times of 15, 17, 20, 25, 35, 45, 55ns
- Data Retention Function (LPA version)
- TTL Compatible Inputs and Outputs
- Fully Static, No Clocks
- Organized as 512Kx8
- Commercial, Industrial and Military Temperature Ranges
- 32 lead JEDEC Approved Evolutionary Pinout
 - Ceramic Sidebraced 600 mil DIP (Package 9)
 - Ceramic Sidebraced 400 mil DIP (Package 326)
 - Ceramic 32 pin Flatpack (Package 344)
 - Ceramic Thin Flatpack (Package 321)
 - Ceramic SOJ (Package 140)
- 36 lead JEDEC Approved Revolutionary Pinout
 - Ceramic Flatpack (Package 316)
 - Ceramic SOJ (Package 327)
 - Ceramic LCC (Package 502)
- Single +5V ($\pm 10\%$) Supply Operation

The EDI88512CA is a 4 megabit Monolithic CMOS Static RAM. The 32 pin DIP pinout adheres to the JEDEC evolutionary standard for the four megabit device. All 32 pin packages are pin for pin upgrades for the single chip enable 128K x 8, the EDI88128CS. Pins 1 and 30 become the higher order addresses.

The 36 pin revolutionary pinout also adheres to the JEDEC standard for the four megabit device. The center pin power and ground pins help to reduce noise in high performance systems. The 36 pin pinout also allows the user an upgrade path to the future 2Mx8.

A Low Power version with Data Retention (EDI88512LPA) is also available for battery backed applications. Military product is available compliant to Appendix A of MIL-PRF-38535.

*This product is subject to change without notice.

FIGURE 1 – PIN CONFIGURATION

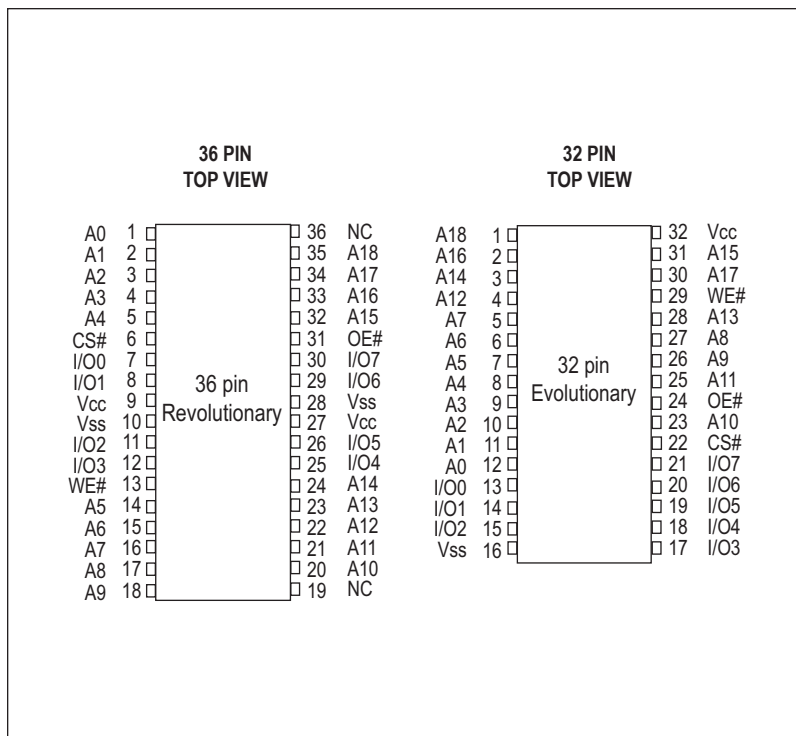

PIN DESCRIPTION

I/O ₀₋₇	Data Inputs/Outputs
A0-18	Address Inputs
WE#	Write Enables
CS#	Chip Selects
OE#	Output Enable
Vcc	Power (+5V $\pm 10\%$)
Vss	Ground
NC	Not Connected

BLOCK DIAGRAM

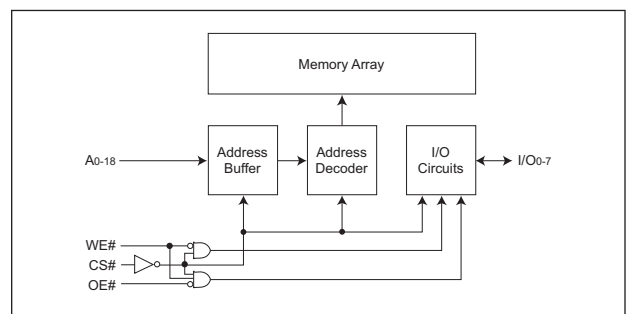

ABSOLUTE MAXIMUM RATINGS

Parameter	Value	Unit
Voltage on any pin relative to Vss	-0.5 to 7.0	V
Operating Temperature T _A (Ambient)		
Commercial	0 ≤ T _A ≤ +70	°C
Industrial	-40 ≤ T _A ≤ +85	°C
Military	-55 ≤ T _A ≤ +125	°C
Storage Temperature, Plastic	-65 ≤ T _A ≤ +150	°C
Power Dissipation	1.5	W
Output Current	20	mA
Junction Temperature, T _J	175	°C

NOTE:

Stress greater than those listed under "Absolute Maximum Ratings" may cause permanent damage to the device. This is a stress rating only and functional operation of the device at these or any other conditions greater than those indicated in the operational sections of this specification is not implied. Exposure to absolute maximum rating conditions for extended periods may affect reliability.

TRUTH TABLE

OE#	CS#	WE#	Mode	Output	Power
X	H	X	Standby	High Z	I _{CC2} , I _{CC3}
H	L	H	Output Deselect	High Z	I _{CC1}
L	L	H	Read	Data Out	I _{CC1}
X	L	L	Write	Data In	I _{CC1}

RECOMMENDED OPERATING CONDITIONS

Parameter	Symbol	Min	Typ	Max	Unit
Supply Voltage	V _{CC}	4.5	5.0	5.5	V
Supply Voltage	V _{SS}	0	0	0	V
Input High Voltage	V _{IH}	2.2	—	V _{CC} + 0.3	V
Input Low Voltage	V _{IL}	-0.3	—	+0.8	V

CAPACITANCE

 (T_A = +25°C)

Parameter	Symbol	Condition	Max	Unit
Address Lines	C _i	V _{IN} = V _{CC} or V _{SS} , f = 1.0MHz	12	pF
Data Lines	C _o	V _{OUT} = V _{CC} or V _{SS} , f = 1.0MHz	14	pF

These parameters are sampled, not 100% tested.

DC CHARACTERISTICS

 (V_{CC} = 5V, T_A = -55°C to +125°C)

Parameter	Symbol	Conditions	Min	Max	Units	
Input Leakage Current	I _{LI}	V _{IN} = 0V to V _{CC}	-10	10	A	
Output Leakage Current	I _{LO}	V _{I/O} = 0V to V _{CC}	-10	10	A	
Operating Power Supply Current	I _{CC1}	WE#, CS# = V _{IL} , I _{I/O} = 0mA, Min Cycle (17ns) (20 -55ns)	—	250	mA	
Standby (TTL) Power Supply Current	I _{CC2}	CS# ≥ V _{IH} , V _{IN} ≤ V _{IL} , V _{IN} ≥ V _{IH}	—	60	mA	
Full Standby Power Supply Current	I _{CC3}	CS# ≥ V _{CC} - 0.2V V _{IN} ≥ V _{CC} - 0.2V or V _{IN} ≤ 0.2V	CA	—	25	mA
			LPA	—	20	mA
Output Low Voltage	V _{OL}	I _{OL} = 6.0mA	—	0.4	V	
Output High Voltage	V _{OH}	I _{OH} = -4.0mA	2.4	—	V	

NOTE: DC test conditions: V_{IL} = 0.3V, V_{IH} = V_{CC} - 0.3V

AC TEST CONDITIONS

Figure 1

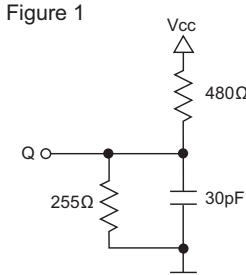
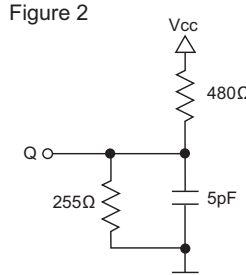

Figure 2



Input Pulse Levels	V _{SS} to 3.0V
Input Rise and Fall Times	5ns
Input and Output Timing Levels	1.5V
Output Load	Figure 1

NOTE: For t_{EH0Z}, t_{GH0Z} and t_{wLOZ}, C_L = 5pF Figure 2)

AC CHARACTERISTICS – READ CYCLE

 (V_{CC} = 5.0V, V_{SS} = 0V, -55°C ≤ T_A ≤ +125°C)

Parameter	Symbol		15ns		17ns		20ns		25ns		35ns		45ns		55ns		Units
	JEDEC	Alt.	Min	Max	Min	Max	Min	Max	Min	Max	Min	Max	Min	Max	Min	Max	
Read Cycle Time	t _{AVAV}	t _{RC}	15		17		20		25		35		45		55		ns
Address Access Time	t _{AVOQ}	t _{AA}		15		17		20		25		35		45		55	ns
Chip Enable Access Time	t _{ELQV}	t _{ACS}		15		17		20		25		35		45		55	ns
Chip Enable to Output in Low Z (1)	t _{ELQX}	t _{CLZ}	2		3		3		3		3		3		3		ns
Chip Disable to Output in High Z (1)	t _{EHQZ}	t _{CHZ}	0	7	0	7	0	8	0	10	0	15	0	20	0	20	ns
Output Hold from Address Change	t _{AVOX}	t _{OH}	0		0		0		0		0		0		0		ns
Output Enable to Output Valid	t _{GLQV}	t _{OE}		8		8		10		12		15		25		30	ns
Output Enable to Output in Low Z (1)	t _{GLQX}	t _{OLZ}	0		0		0		0		0		0		0		ns
Output Disable to Output in High Z(1)	t _{GHQZ}	t _{OHZ}	0	7	0	7	0	8	0	10	0	15	0	20	0	20	ns

1. This parameter is guaranteed by design but not tested.

AC CHARACTERISTICS – WRITE CYCLE

 (V_{CC} = 5.0V, V_{SS} = 0V, -55°C ≤ T_A ≤ +125°C)

Parameter	Symbol		15ns		17ns		20ns		25ns		35ns		45ns		55ns		Units
	JEDEC	Alt.	Min	Max	Min	Max	Min	Max	Min	Max	Min	Max	Min	Max	Min	Max	
Write Cycle Time	t _{AVAV}	t _{WC}	15		17		20		25		35		45		55		ns
Chip Enable to End of Write	t _{ELWH}	t _{CW}	13		14		15		17		25		30		50		ns
	t _{ELEH}	t _{CW}	13		14		15		17		25		30		50		ns
Address Setup Time	t _{AWL}	t _{AS}	0		0		0		0		0		0		0		ns
	t _{AVEL}	t _{AS}	0		0		0		0		0		0		0		ns
Address Valid to End of Write	t _{AWWH}	t _{AW}	13		14		15		17		25		30		50		ns
	t _{AVEH}	t _{AW}	13		14		15		17		25		30		50		ns
Write Pulse Width	t _{WLWH}	t _{WP}	13		14		15		17		25		30		45		ns
	t _{WLEH}	t _{WP}	13		14		15		17		25		30		45		ns
Write Recovery Time	t _{WHAX}	t _{WR}	0		0		0		0		0		0		0		ns
	t _{EHAX}	t _{WR}	0		0		0		0		0		0		0		ns
Data Hold Time	t _{WHDX}	t _{DH}	0		0		0		0		0		0		0		ns
	t _{EHDX}	t _{DH}	0		0		0		0		0		0		0		ns
Write to Output in High Z (1)	t _{WLOZ}	t _{WHZ}	0	8	0	8	0	8	0	10	0	25	0	30	0	30	ns
Data to Write Time	t _{DVWH}	t _{DW}	8		8		10		12		20		25		40		ns
	t _{DVEH}	t _{DW}	8		8		10		12		20		25		30		ns
Output Active from End of Write (1)	t _{WHQX}	t _{WLZ}	0		0		0		0		0		0		0		ns

1. This parameter is guaranteed by design but not tested.

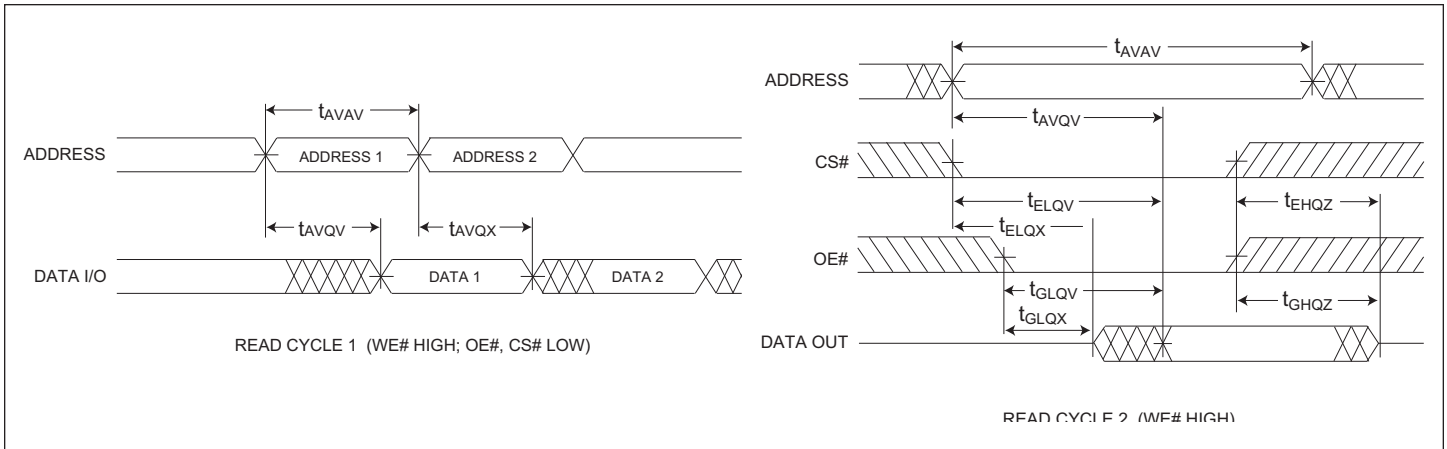
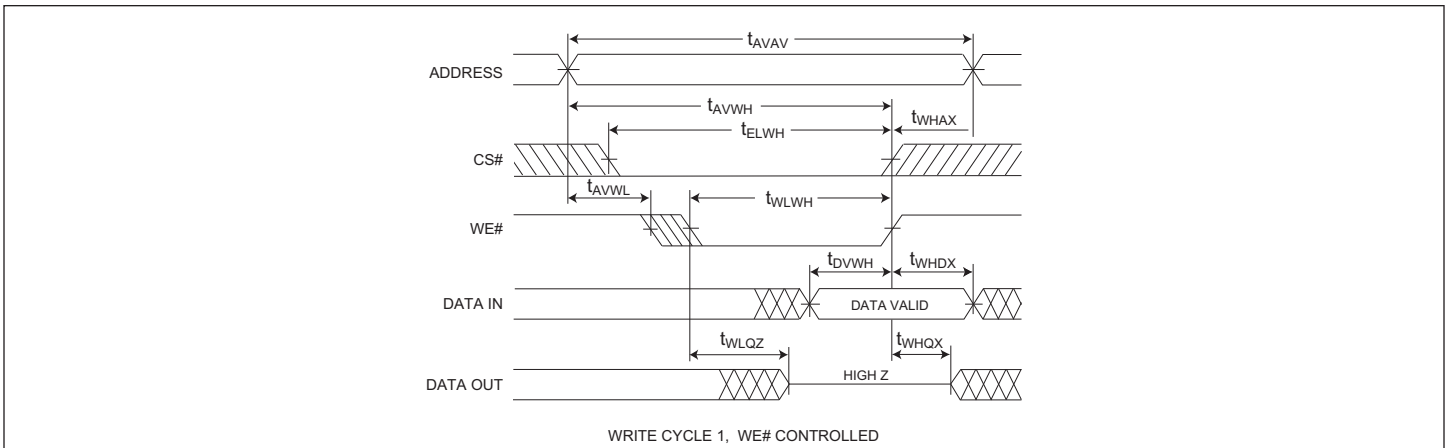
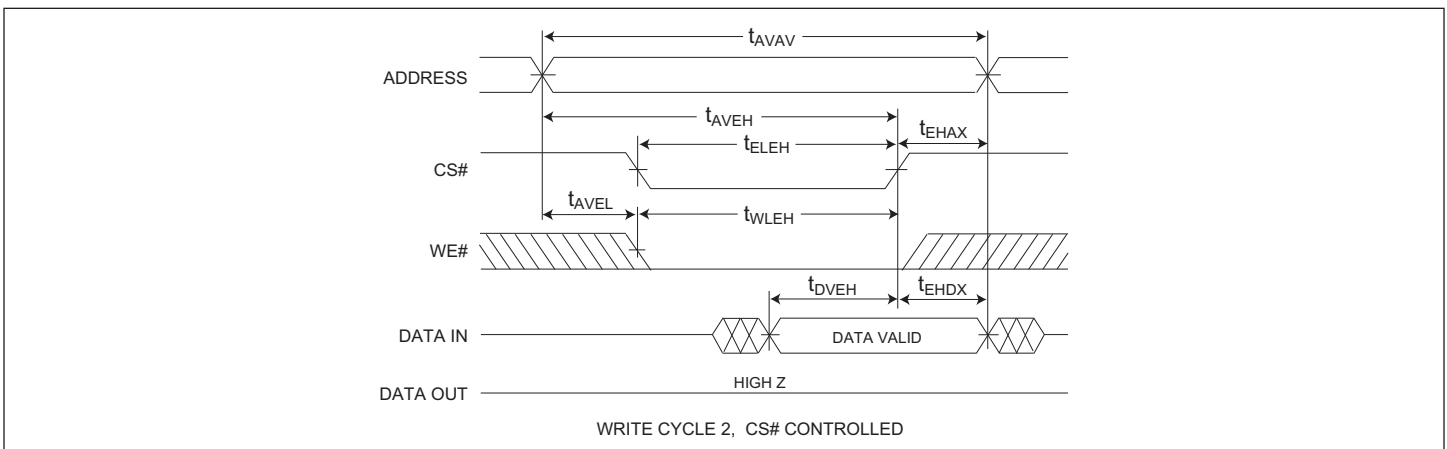
FIGURE 2 – TIMING WAVEFORM – READ CYCLE

FIGURE 3 – WRITE CYCLE – WE# CONTROLLED

FIGURE 4 – WRITE CYCLE – CS# CONTROLLED

DATA RETENTION CHARACTERISTICS (EDI88512LPA ONLY)

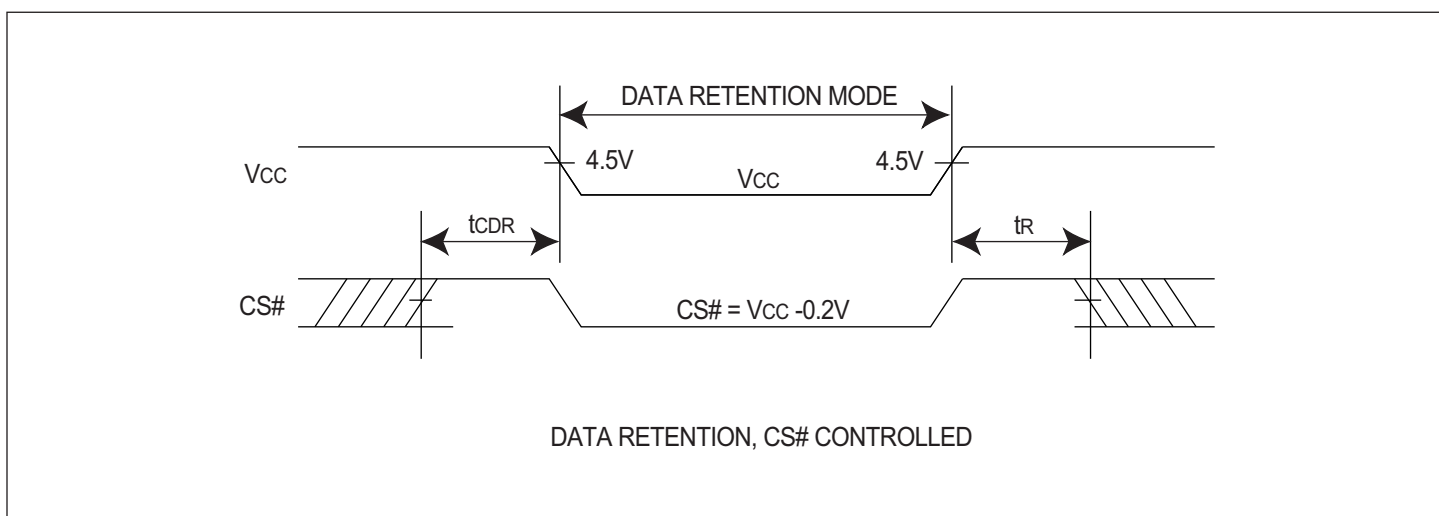
 (-55°C ≤ T_A ≤ +125°C)

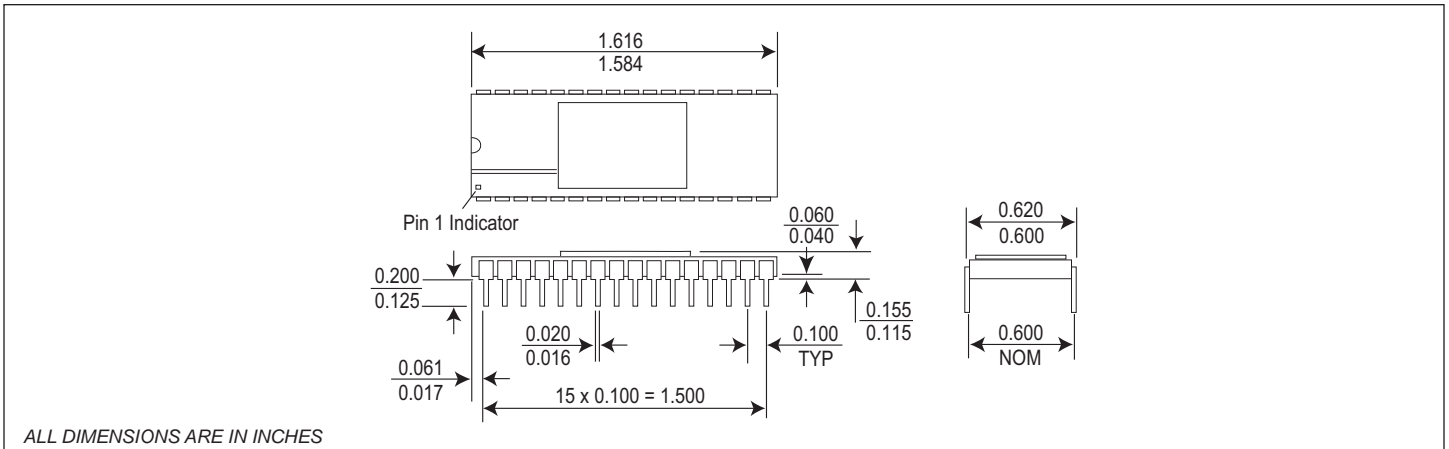
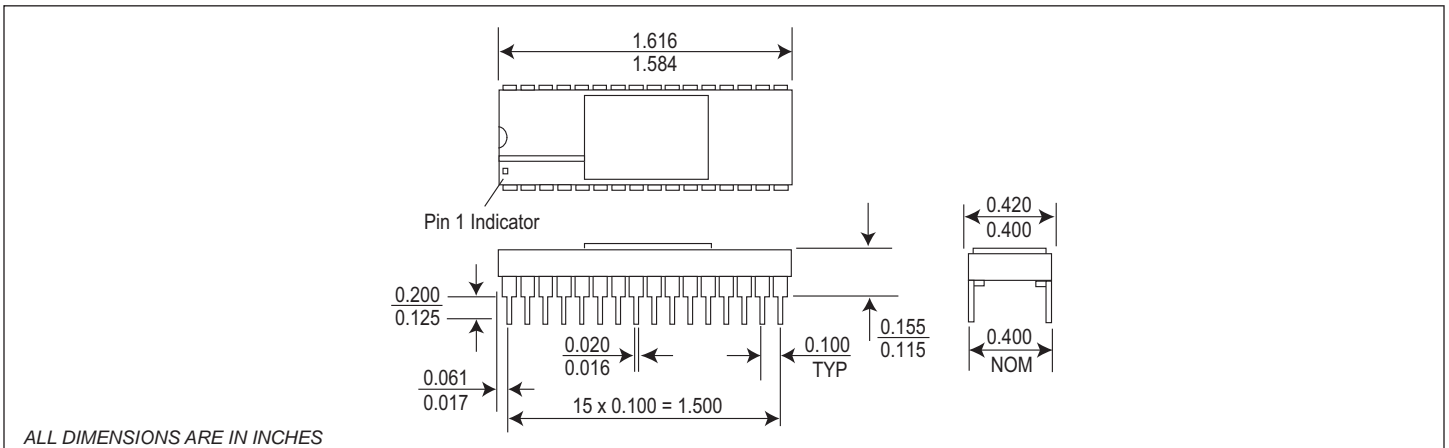
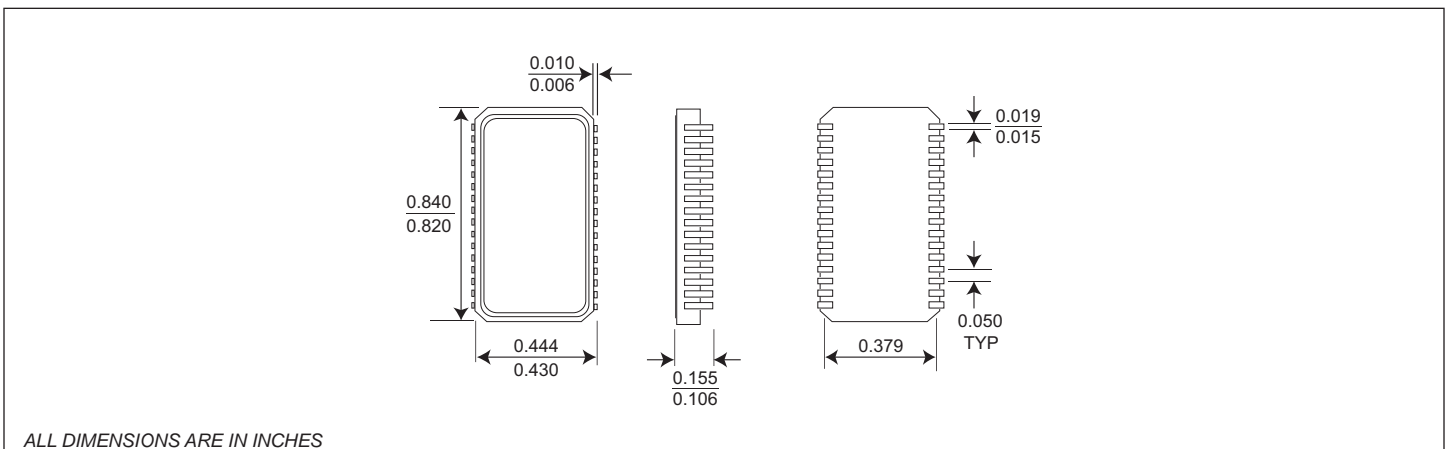
Characteristic Low Power Version only	Sym	Conditions	Min	Typ	Max	Units
Data Retention Voltage	V _{CC}	V _{CC} = 2.0V	2	–	–	V
Data Retention Quiescent Current	I _{CCDR}	CS# ≥ V _{CC} - 0.2V	–	–	2	mA
Chip Disable to Data Retention Time	t _{CDR}	V _{IN} ≥ V _{CC} - 0.2V	0	–	–	ns
Operation Recovery Time	T _R	or V _{IN} ≤ 0.2V	t _{AVAV}	–	–	ns

FIGURE 5 – DATA RETENTION – CS# CONTROLLED

PACKAGE 9: 32 LEAD SIDEBRAZED CERAMIC DIP, SMD 5962-95600XXMXA

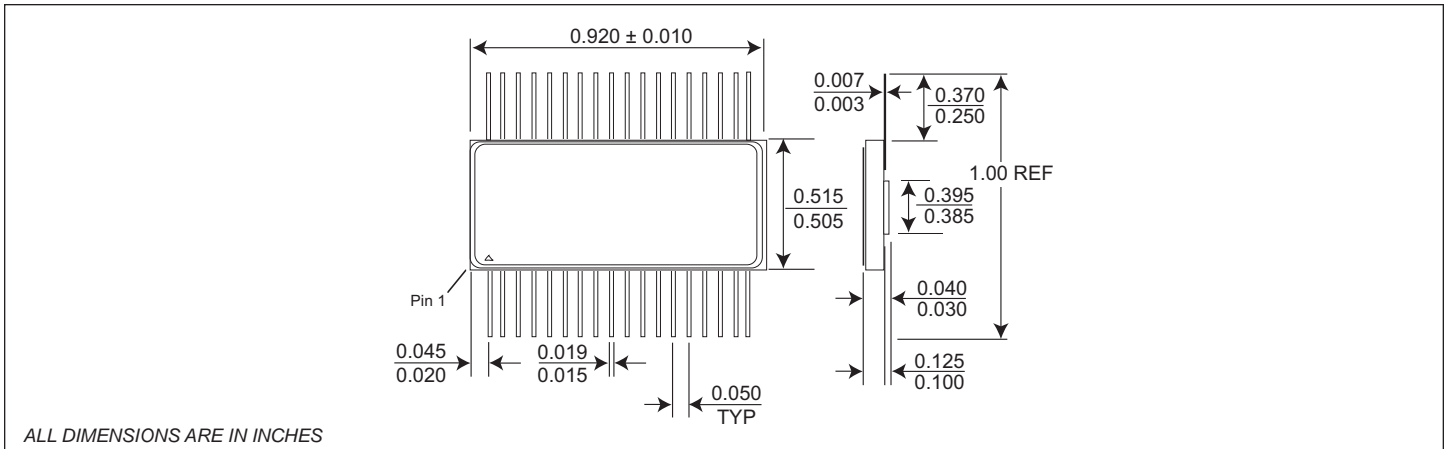
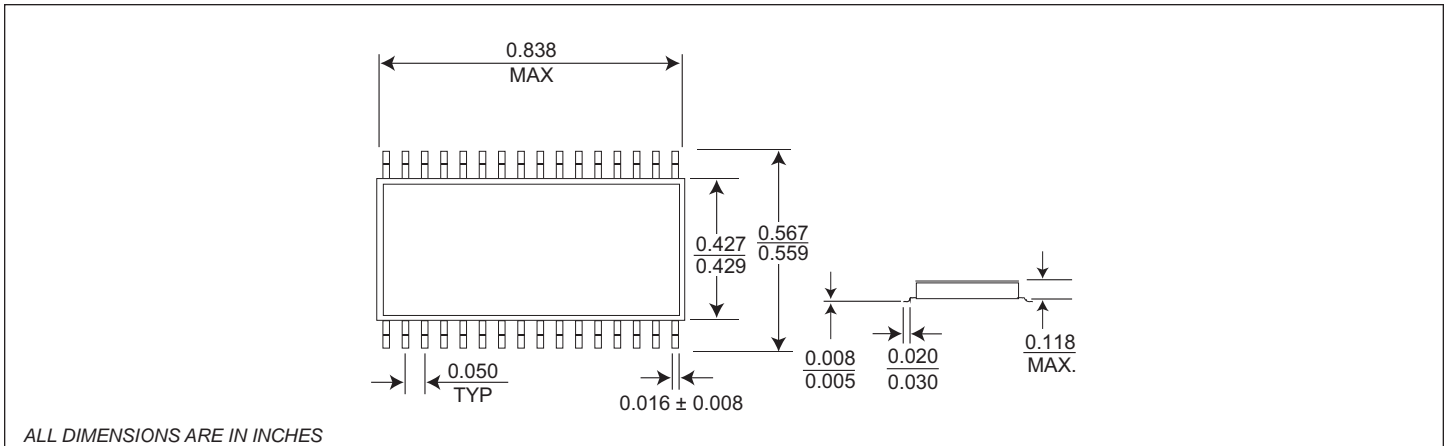
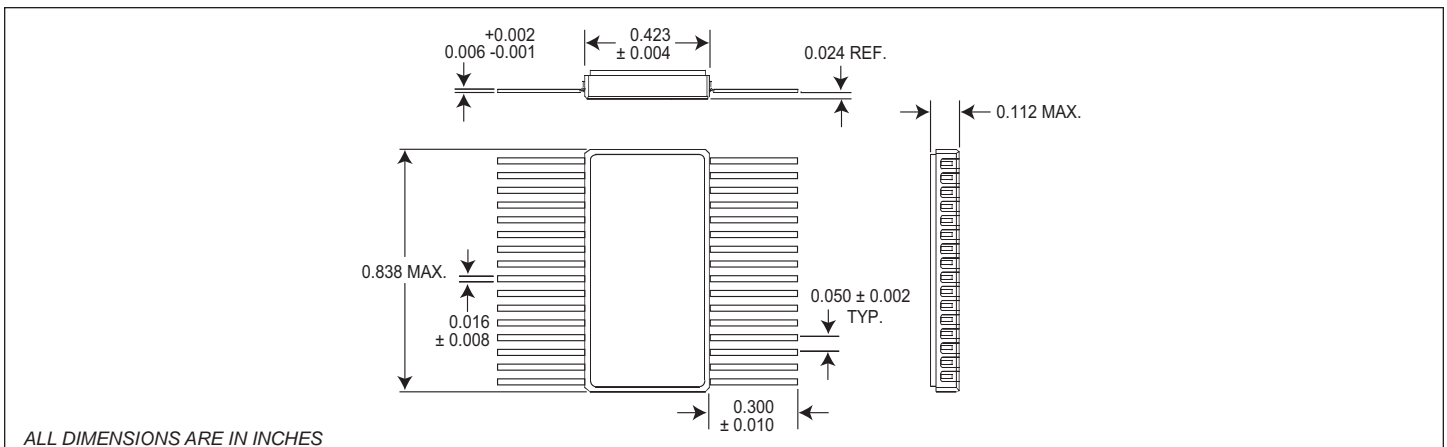
PACKAGE 326: 32 LEAD SIDEBRAZED CERAMIC DIP

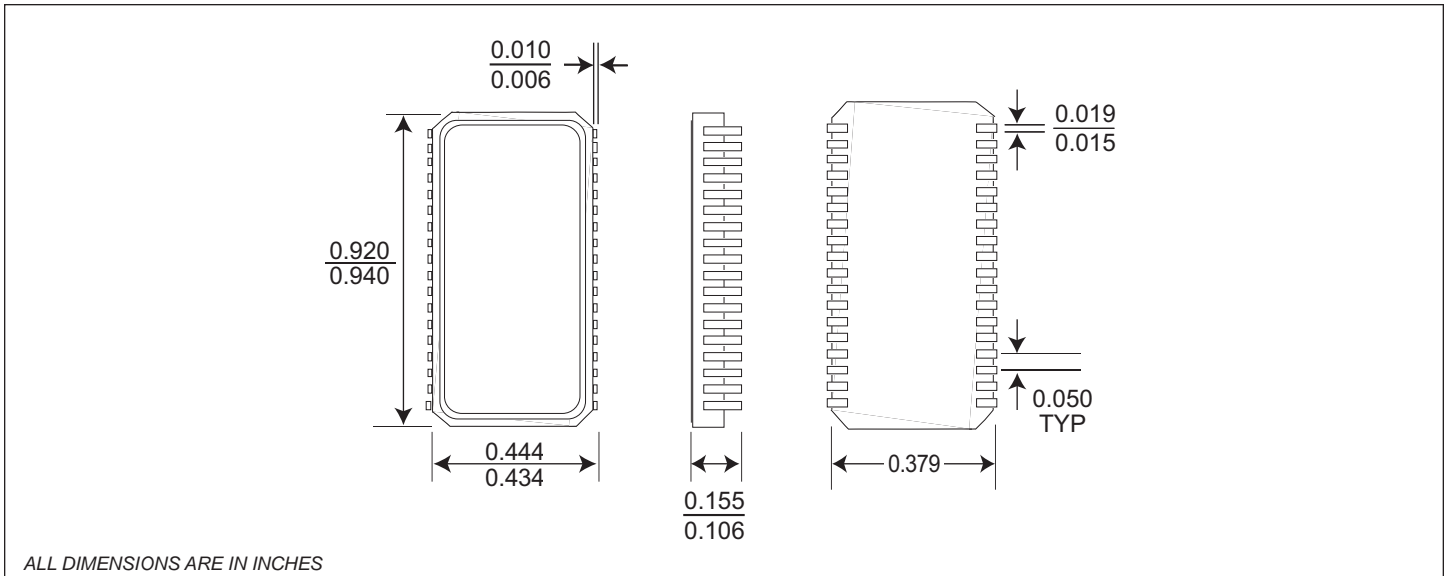
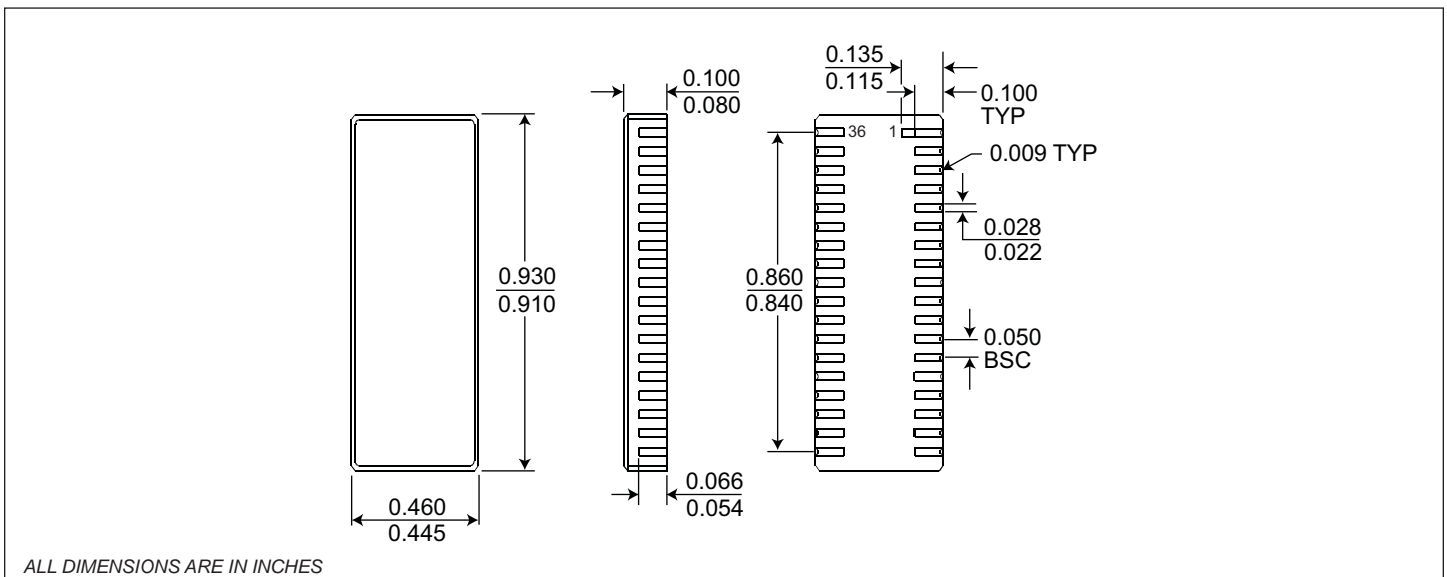
PACKAGE 140: 32 LEAD CERAMIC SOJ, SMD 5962-95600XXMUA

PACKAGE 316: 36 PIN CERAMIC FLATPACK, SMD 5962-95600XXMTA

PACKAGE 321: 32 PIN THINPACK™ FLATPACK, SMD 5962-95600XXMYA

PACKAGE 344: 32 PIN CERAMIC FLATPACK, SMD 5962-95600XXM9A

PACKAGE 327: 36 LEAD CERAMIC SOJ, SMD 5962-95600XXMMA

PACKAGE 502: 36 LEAD CERAMIC LCC

ORDERING INFORMATION
EDI 8 8 512 CA X X X
MICROSEMI CORPORATION: _____

SRAM: _____

ORGANIZATION, 512Kx8: _____

TECHNOLOGY: _____

 CA = CMOS Standard Power
 LPA = Low Power

ACCESS TIME (ns): _____

PACKAGE TYPE: _____

 C = 32 lead Sidebrazed DIP, 600 mil (Package 9)
 K = 36 lead Ceramic LCC (Package 502)
 N = 32 lead Ceramic SOJ (Package 140)
 T = 32 lead Sidebrazed DIP, 400 mil (Package 326)
 B32 = 32 pin Ceramic Thinpack™ Flatpack (Package 321)
 F32 = 32 pin Ceramic Flatpack (Package 344)
 F36 = 36 pin Ceramic Flatpack (Package 316)
 N36 = 36 lead Ceramic SOJ (Package 327)

DEVICE GRADE: _____

 B = MIL-STD-883 Compliant
 M = Military Screened $-55^{\circ}\text{C} \leq T_A \leq +125^{\circ}\text{C}$
 I = Industrial $-40^{\circ}\text{C} \leq T_A \leq +85^{\circ}\text{C}$
 C = Commercial $0^{\circ}\text{C} \leq T_A \leq +70^{\circ}\text{C}$

Document Title

512Kx8 Monolithic SRAM, SMD 5962-95600

Revision History

Rev #	History	Release Date	Status
Rev 13	Changes (Pg. 1-10) 13.1 Change document layout from White Electronic Designs to Microsemi 13.2 Add document Revision History page	February 2011	Final