

Customer Information Sheet

DRAWING No.: M80-681XXXX

SHEET 2 OF 2

IF IN DOUBT - ASK

(C)

NOT TO SCALE

THIRD ANGLE PROJECTION

ALL DIMENSIONS IN mm

ASSEMBLY PART No.	No. OF CONTACTS	DIM 'X'	DIM 'Y'
M80-68104XX	4	2.00	7.15
M80-68106XX	6	4.00	9.15
M80-68108XX	8	6.00	11.15
M80-68110XX	10	8.00	13.15
M80-68112XX	12	10.00	15.15
M80-68114XX	14	12.00	17.15
M80-68116XX	16	14.00	19.15
M80-68118XX	18	16.00	21.15
M80-68120XX	20	18.00	23.15
M80-68126XX	26	24.00	29.15
M80-68134XX	34	32.00	37.15
M80-68144XX	44	42.00	47.15

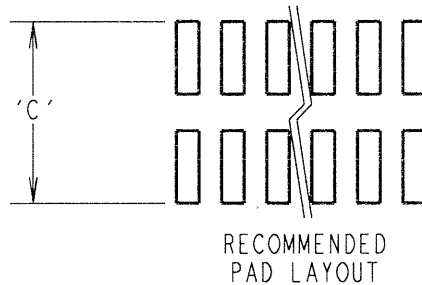
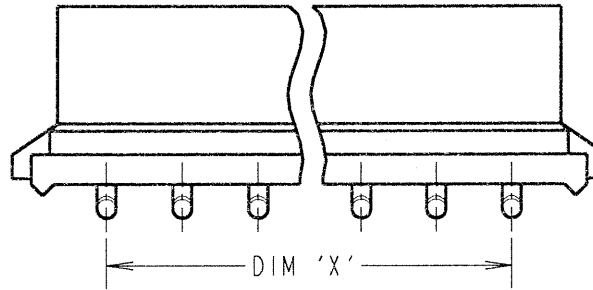
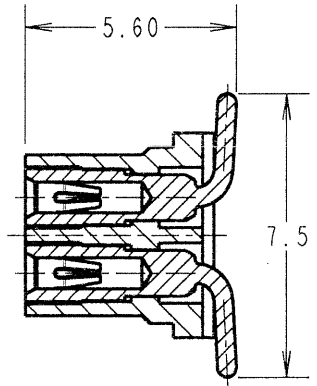
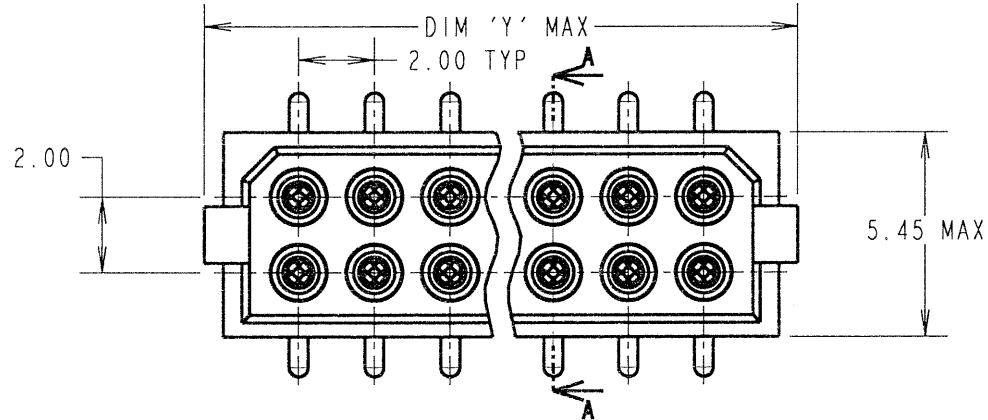

SPECIFICATIONS:

MATERIAL:
 MOULDING = GLASS-FILLED POLYAMIDE 46, UL94V-0, BLACK
 CONTACT CLIP = BERYLLIUM COPPER
 CONTACT SHELL = BRASS

FINISH:
 01 = 0.3µ GOLD CLIP, 4µ TIN/LEAD SHELL
 05 = 0.3µ GOLD CLIP, 0.3µ GOLD SHELL
 T6 = 1.3µ 90/10 TIN/LEAD CLIP, 4µ TIN/LEAD SHELL
 42 = 0.3µ GOLD CLIP, 4µ 100% TIN SHELL

ELECTRICAL:
 CURRENT RATING AT 25°C = 3.0A MAX
 CURRENT RATING AT 85°C = 2.2A MAX
 WORKING VOLTAGE = 120V AC/DC
 VOLTAGE PROOF = 360V AC/DC
 CONTACT RESISTANCE = 25 mΩ MAX
 INSULATION RESISTANCE = 100 MΩ MIN

MECHANICAL:
 DURABILITY = 500 OPERATIONS
 INSERTION FORCE = 2.8N MAX, 1.0N MIN
 WITHDRAWAL FORCE = 1.8N MAX, 0.2N MIN

ENVIRONMENTAL:
 TEMPERATURE RANGE = -55°C TO +125°C

PACKING:
 TUBE

NOTES:

1. FOR CONNECTOR WITH PICK AND PLACE PAD, SEE DRAWING M80-681XXXXP.

ORDER CODE: **M80-681XXXX**

TOTAL No. OF CONTACTS
 04, 06, 08, 10, 12, 14,
 16, 18, 20, 26, 34, 44

FINISH
 01 - GOLD CLIP, TIN/LEAD SHELL
 05 - GOLD CLIP, GOLD SHELL
 T6 - TIN/LEAD CLIP, TIN/LEAD SHELL
 42 - GOLD CLIP, 100% TIN SHELL

JMB	C	02.08.06	9355
NAME	ISS.	DATE	C/NOTE
APPROVED: <i>J.B.</i>			
CHECKED: <i>[Signature]</i>			
DRAWN: W. J. BOURNE			
CUSTOMER REF.:			
ASSEMBLY DRG:			

HARWIN

THIS DRAWING AND ANY INFORMATION OR DESCRIPTIVE MATTER SET OUT HEREON ARE CONFIDENTIAL AND COPYRIGHT PROPERTY OF THE HARWIN GROUP AND MUST NOT BE DISCLOSED, LOANED, COPIED OR USED FOR MANUFACTURING, TENDERING OR FOR ANY OTHER PURPOSE WITHOUT THEIR WRITTEN PERMISSION.

TOLERANCES

X. = ±1mm
 X.X = ±0.25mm
 X.XX = ±0.10mm
 X.XXX = ±0.01mm
 ANGLES = ±5°
 UNLESS STATED

MATERIAL:

SEE ABOVE

FINISH:

SEE ABOVE

S/AREA:

mm²

TITLE:

DATAMATE DIL VERTICAL SMT SOCKET ASSEMBLY

DRAWING NUMBER:

M80-681XXXX

HARWIN INC
 U.S.A.
 TEL: (812) 542 2540
 FAX: (812) 542 2541

HARWIN PLC
 U.K.
 TEL: 023 9231 4545
 FAX: 023 9231 4590

HARWIN PTE
 SINGAPORE
 TEL: 65 6779 4909
 FAX: 65 6779 3868