

ESAC39(C,N,D) (5A)

(400V to 600V / 5A)

FAST RECOVERY DIODE

Features

- Super high speed switching
- Low VF in turn on
- High reliability

Applications

- High speed switching

Maximum ratings and characteristics

- Absolute maximum ratings

Item	Symbol	Conditions	Rating		Unit
			-04	-06	
Repetitive peak reverse voltage	V_{RRM}		400	600	V
Non-repetitive peak reverse voltage	V_{RSM}		400	600	V
Average output current	I_o	Square wave, duty=1/2, $T_c=115^\circ\text{C}$	5*		A
Surge current	I_{FSM}	Sine wave 10ms	20		A
Operating junction temperature	T_j		-40 to +150		$^\circ\text{C}$
Storage temperature	T_{stg}		-40 to +150		$^\circ\text{C}$

*Average forward current of centertap full wave connection

- Electrical characteristics ($T_a=25^\circ\text{C}$ Unless otherwise specified)

Item	Symbol	Conditions	Max.	Unit
Forward voltage drop	V_{FM}	$I_{FM}=2\text{A}$	2.5	V
Reverse current	I_{RRM}	$V_R=V_{RRM}$	100	μA
Reverse recovery time	t_{rr}	$I_F=0.1\text{A}$, $I_R=0.2\text{A}$, $I_{rec}=0.05\text{A}$	50	ns
Thermal resistance	$R_{th(j-c)}$	Junction to case	3.0	$^\circ\text{C/W}$

Outline drawings, mm

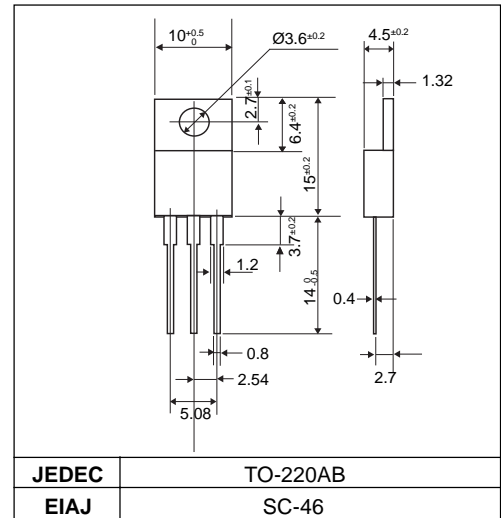

Connection diagram

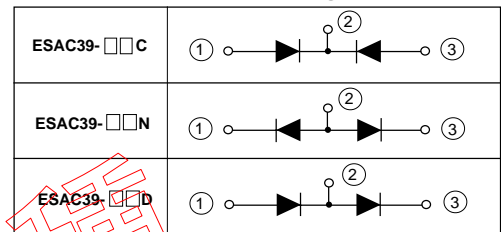

Characteristics

Forward characteristics

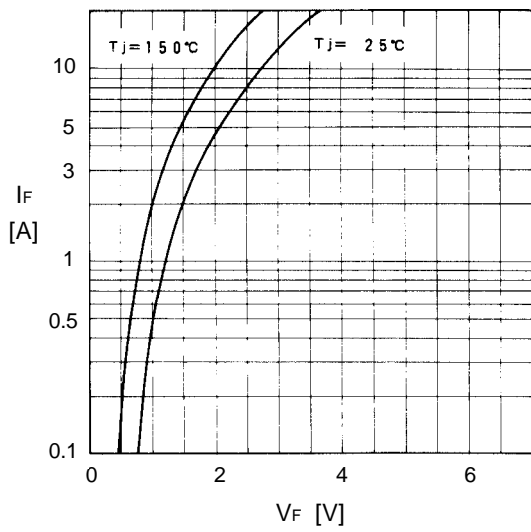

Reverse characteristics

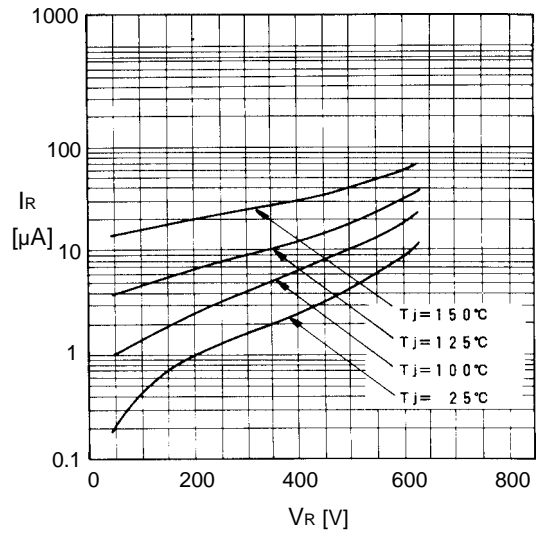

Forward power dissipation

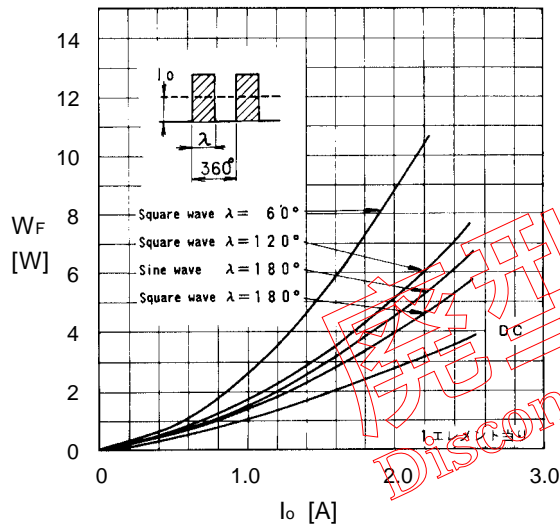

Output current-case temperature

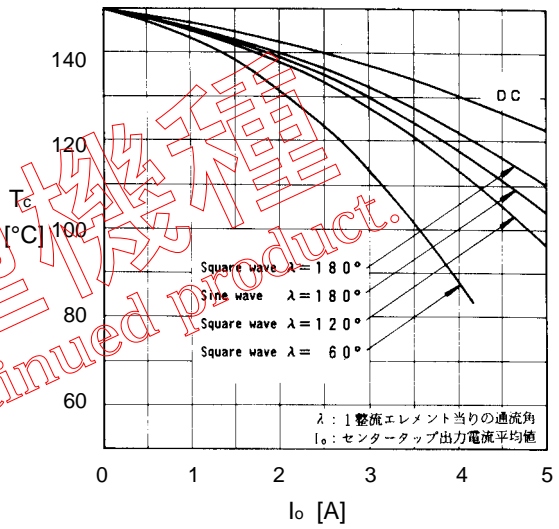

Junction capacitance characteristics

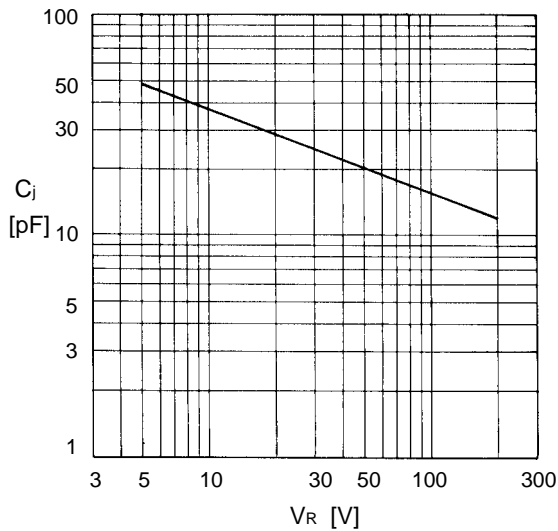

Surge capability

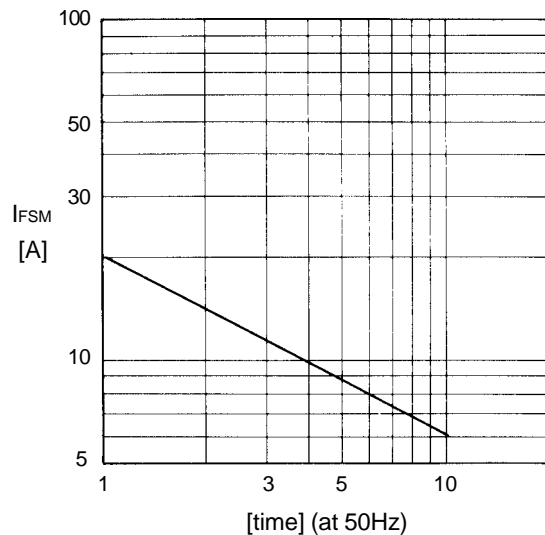

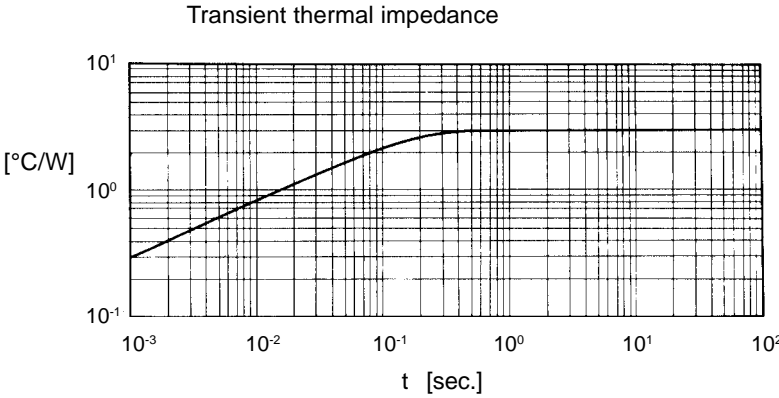

廃型機種
Discontinued product.