

SN54ALS576B, SN54AS576 SN74ALS576B, SN74ALS577A, SN74AS576 OCTAL D-TYPE EDGE-TRIGGERED FLIP-FLOPS WITH 3-STATE OUTPUTS

SDAS086B - DECEMBER 1982 - REVISED JANUARY 1985

- 3-State Buffer-Type Inverting Outputs Drive Bus Lines Directly
- Bus-Structured Pinout
- Buffered Control Inputs
- SN74ALS577A Has Synchronous Clear
- Package Options Include Plastic Small-Outline (DW) Packages, Ceramic Chip Carriers (FK), Standard Plastic (N, NT) and Ceramic (J) 300-mil DIPs, and Ceramic Flat (W) Packages

description

These octal D-type edge-triggered flip-flops feature 3-state outputs designed specifically for bus driving. They are particularly suitable for implementing buffer registers, I/O ports, bidirectional bus drivers, and working registers.

These flip-flops enter data on the low-to-high transition of the clock (CLK) input.

The output-enable (\overline{OE}) input does not affect internal operations of the flip-flops. Old data can be retained or new data can be entered while the outputs are disabled.

The SN54ALS576B and SN54AS576 are characterized for operation over the full military temperature range of -55°C to 125°C . The SN74ALS576B, SN74ALS577A, and SN74AS576 are characterized for operation from 0°C to 70°C .

SN54ALS576B, SN54AS576 . . . J OR W PACKAGE
SN74ALS576B, SN74AS576 . . . DW OR N PACKAGE
(TOP VIEW)

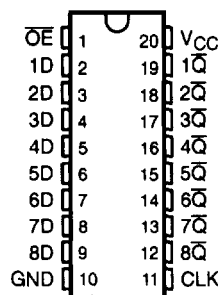

SN54ALS576B, SN54AS576 . . . FK PACKAGE
(TOP VIEW)

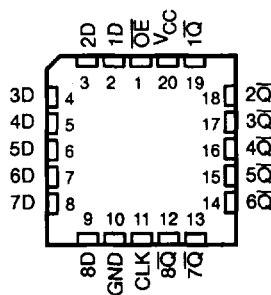

SN74ALS577A . . . DW OR NT PACKAGE
(TOP VIEW)

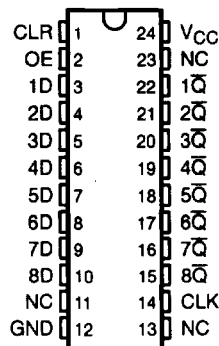

NC - No internal connection

PRODUCTION DATA information is current as of publication date. Products conform to specifications per the terms of Texas Instruments standard warranty. Production processing does not necessarily include testing of all parameters.



POST OFFICE BOX 655303 • DALLAS, TEXAS 75266

Copyright © 1995, Texas Instruments Incorporated

SN54ALS576B, SN54AS576
SN74ALS576B, SN74ALS577A, SN74AS576
OCTAL D-TYPE EDGE-TRIGGERED FLIP-FLOPS WITH 3-STATE OUTPUTS
 SDAS065B - DECEMBER 1982 - REVISED JANUARY 1995

Function Tables

'ALS576B, 'AS576
 (each flip-flop)

INPUTS			OUTPUT
OE	CLK	D	Q
L	↑	H	L
L	↑	L	H
L	L	X	\bar{Q}_0
H	X	X	Z

SN74ALS577A
 (each flip-flop)

INPUTS				OUTPUT
OE	CLR	CLK	D	Q
L	L	↑	X	H
L	H	↑	H	L
L	H	↑	L	H
L	H	L	X	\bar{Q}_0
H	X	X	X	Z

logic symbol†

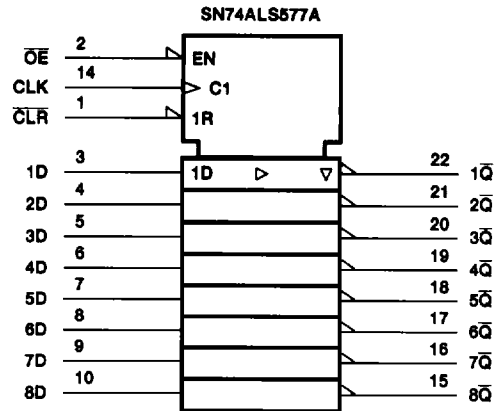
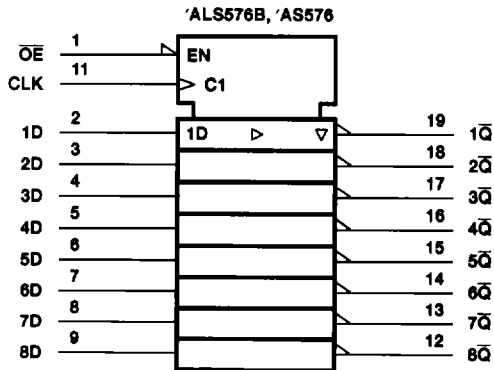

† These symbols are in accordance with ANSI/IEEE Std 91-1984 and IEC Publication 617-12.

Pin numbers shown for the 'ALS576B and 'AS576 are for the DW, J, N, and W packages.

Pin numbers shown for the SN74ALS577A are for the DW and NT packages.

SN54ALS576B, SN54AS576
SN74ALS576B, SN74ALS577A, SN74AS576
OCTAL D-TYPE EDGE-TRIGGERED FLIP-FLOPS WITH 3-STATE OUTPUTS

SDAS066B - DECEMBER 1982 - REVISED JANUARY 1985

logic diagrams (positive logic)

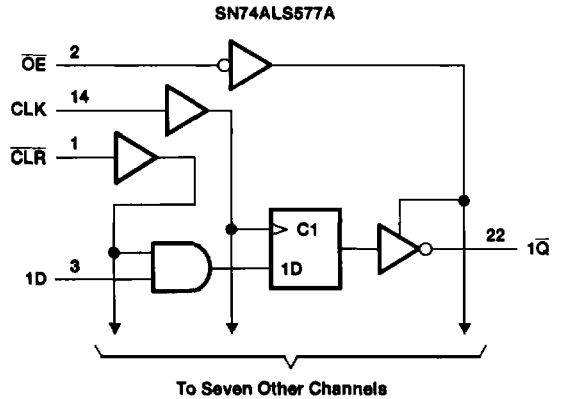
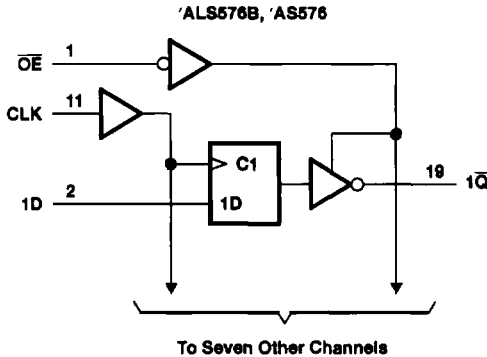

Pin numbers shown are for the DW, J, N, and W packages.

Pin numbers shown are for the DW and NT packages.

absolute maximum ratings over operating free-air temperature range (unless otherwise noted)†

Supply voltage, V_{CC}	7 V
Input voltage, V_I	7 V
Voltage applied to a disabled 3-state output	5.5 V
Operating free-air temperature range, T_A : SN54ALS576B	-55°C to 125°C
SN74ALS576B, SN74ALS577A	0°C to 70°C
Storage temperature range	-65°C to 150°C

† Stresses beyond those listed under "absolute maximum ratings" may cause permanent damage to the device. These are stress ratings only, and functional operation of the device at these or any other conditions beyond those indicated under "recommended operating conditions" is not implied. Exposure to absolute-maximum-rated conditions for extended periods may affect device reliability.

recommended operating conditions

		SN54ALS576B			SN74ALS576B SN74ALS577A			UNIT
		MIN	NOM	MAX	MIN	NOM	MAX	
V_{CC}	Supply voltage	4.5	5	5.5	4.5	5	5.5	V
V_{IH}	High-level input voltage	2			2			V
V_{IL}	Low-level input voltage			0.7			0.8	V
I_{OH}	High-level output current			-1			-2.6	mA
I_{OL}	Low-level output current			12			24	mA
f_{clock}	Clock frequency	'ALS576B			0		30	MHz
		SN74ALS577A					30	
t_w	Pulse duration	'ALS576B, CLK high or low			16.5			ns
		SN74ALS577A, CLK high or low			16.5			
t_{su}	Setup time before CLK↑	Data			15			ns
		SN74ALS577A CLR			15			
t_h	Hold time after CLK↑	Data			0			ns
		SN74ALS577A CLR			0			
T_A	Operating free-air temperature	-55		125	0		70	°C



POST OFFICE BOX 655303 • DALLAS, TEXAS 75265

SN54ALS576B, SN54AS576
SN74ALS576B, SN74ALS577A, SN74AS576
OCTAL D-TYPE EDGE-TRIGGERED FLIP-FLOPS WITH 3-STATE OUTPUTS
SDAS065B - DECEMBER 1982 - REVISED JANUARY 1995

electrical characteristics over recommended operating free-air temperature range (unless otherwise noted)

PARAMETER	TEST CONDITIONS		SN54ALS576B		SN74ALS576B SN74ALS577A		UNIT
			MIN	TYP†	MAX	MIN	
V_{IK}	$V_{CC} = 4.5\text{ V}$, $I_I = -18\text{ mA}$				-1.2		V
V_{OH}	$V_{CC} = 4.5\text{ V to }5.5\text{ V}$, $I_{OH} = -0.4\text{ mA}$		$V_{CC} - 2$		$V_{CC} - 2$		V
	$V_{CC} = 4.5\text{ V}$	$I_{OH} = -1\text{ mA}$	2.4 3.3				
		$I_{OH} = -2.6\text{ mA}$			2.4 3.2		
V_{OL}	$V_{CC} = 4.5\text{ V}$		$I_{OL} = 12\text{ mA}$		0.25 0.4		V
			$I_{OL} = 24\text{ mA}$		0.35 0.5		
I_{OZH}	$V_{CC} = 5.5\text{ V}$,	$V_O = 2.7\text{ V}$			20		μA
I_{OZL}	$V_{CC} = 5.5\text{ V}$,	$V_O = 0.4\text{ V}$			-20		μA
I_I	$V_{CC} = 5.5\text{ V}$,	$V_I = 7\text{ V}$			0.1		mA
I_{IH}	$V_{CC} = 5.5\text{ V}$,	$V_I = 2.7\text{ V}$			20		μA
I_{IL}	$V_{CC} = 5.5\text{ V}$,	$V_I = 0.4\text{ V}$			-0.2		mA
$I_{O\ddagger}$	$V_{CC} = 5.5\text{ V}$,	$V_O = 2.25\text{ V}$	-20	-112	-30	-112	mA
I_{CC}	$V_{CC} = 5.5\text{ V}$		Outputs high		10	18	mA
			Outputs low		15	24	
			Outputs disabled		16	30	

† All typical values are at $V_{CC} = 5\text{ V}$, $T_A = 25^\circ\text{C}$.

‡ The output conditions have been chosen to produce a current that closely approximates one half of the true short-circuit output current, I_{OS} .

switching characteristics (see Figure 1)

PARAMETER	FROM (INPUT)	TO (OUTPUT)	$V_{CC} = 4.5\text{ V to }5.5\text{ V}$, $C_L = 50\text{ pF}$, $R_1 = 500\ \Omega$, $R_2 = 500\ \Omega$, $T_A = \text{MIN to MAX}\S$						UNIT
			SN54ALS576B		SN74ALS576B		SN74ALS577A		
			MIN	MAX	MIN	MAX	MIN	MAX	
f_{max}			22		30		30		MHz
t_{PLH}	CLK	Any \bar{Q}	4	24	3	14	4	14	ns
t_{PHL}			4	20	4	14	4	14	
t_{PZH}	\bar{OE}	Any \bar{Q}	4	24	3	18	4	18	ns
t_{PZL}			3	23	4	18	4	18	
t_{PHZ}	\bar{OE}	Any \bar{Q}	2	14	1	10	2	10	ns
t_{PLZ}			3	29	2	15	3	15	

§ For conditions shown as MIN or MAX, use the appropriate value specified under recommended operating conditions.



SN54ALS576B, SN54AS576
SN74ALS576B, SN74ALS577A, SN74AS576
OCTAL D-TYPE EDGE-TRIGGERED FLIP-FLOPS WITH 3-STATE OUTPUTS

SDAS065B - DECEMBER 1982 - REVISED JANUARY 1995

absolute maximum ratings over operating free-air temperature range (unless otherwise noted)†

Supply voltage, V_{CC}	7 V
Input voltage, V_I	7 V
Voltage applied to a disabled 3-state output	5.5 V
Operating free-air temperature range, T_A : SN54AS576	-55°C to 125°C
SN74AS576	0°C to 70°C
Storage temperature range	-65°C to 150°C

† Stresses beyond those listed under "absolute maximum ratings" may cause permanent damage to the device. These are stress ratings only, and functional operation of the device at these or any other conditions beyond those indicated under "recommended operating conditions" is not implied. Exposure to absolute-maximum-rated conditions for extended periods may affect device reliability.

recommended operating conditions

		SN54AS576			SN74AS576			UNIT
		MIN	NOM	MAX	MIN	NOM	MAX	
V_{CC}	Supply voltage	4.5	5	5.5	4.5	5	5.5	V
V_{IH}	High-level input voltage	2			2			V
V_{IL}	Low-level input voltage			0.8			0.8	V
I_{OH}	High-level output current			-12			-15	mA
I_{OL}	Low-level output current			32			48	mA
f_{clock}^*	Clock frequency	0		100	0		125	MHz
t_w^*	Pulse duration	CLK high		5	4		ns	
		CLK low		4	2			
t_{su}^*	Setup time, data before CLK↑	3			2			ns
t_h^*	Hold time, data after CLK↑	3			2			ns
T_A	Operating free-air temperature	-55		125	0		70	°C

* On products compliant to MIL-STD-883, Class B, this parameter is based on characterization data but is not production tested.



SN54ALS576B, SN54AS576
SN74ALS576B, SN74ALS577A, SN74AS576
OCTAL D-TYPE EDGE-TRIGGERED FLIP-FLOPS WITH 3-STATE OUTPUTS

SDAS065B - DECEMBER 1982 - REVISED JANUARY 1986

electrical characteristics over recommended operating free-air temperature range (unless otherwise noted)

PARAMETER	TEST CONDITIONS		SN54AS576		SN74AS576		UNIT	
			MIN	TYPT [†] MAX	MIN	TYPT [†] MAX		
V _{IK}	V _{CC} = 4.5 V, I _I = -18 mA		-1.2		-1.2		V	
V _{OH}	V _{CC} = 4.5 V to 5.5 V, I _{OH} = -2 mA		V _{CC} - 2		V _{CC} - 2		V	
	V _{CC} = 4.5 V	I _{OH} = -12 mA	2.4	3.2				
		I _{OH} = -15 mA			2.4	3.3		
V _{OL}	V _{CC} = 4.5 V		0.29 0.5				V	
	I _{OL} = 32 mA				0.33	0.5		
	I _{OL} = 48 mA							
I _{OZH}	V _{CC} = 5.5 V,	V _O = 2.7 V	50		50		μA	
I _{OZL}	V _{CC} = 5.5 V,	V _O = 0.4 V	-50		-50		μA	
I _I	V _{CC} = 5.5 V,	V _I = 7 V	0.1		0.1		mA	
I _{IH}	V _{CC} = 5.5 V,	V _I = 2.7 V	20		20		μA	
I _{IL}	D All others	V _{CC} = 5.5 V,	V _I = 0.4 V	-3		-2		mA
				-0.5		-0.5		
I _{O[‡]}	V _{CC} = 5.5 V,	V _O = 2.25 V	-30	-112	-30	-112	mA	
I _{CC}	V _{CC} = 5.5 V		77 125		77 125		mA	
	Outputs high							
	Outputs low		84 135		84 135			
	Outputs disabled		84 135		84 135			

[†] All typical values are at V_{CC} = 5 V, T_A = 25°C.

[‡] The output conditions have been chosen to produce a current that closely approximates one half of the true short-circuit output current, I_{OS}.

switching characteristics (see Figure 1)

PARAMETER	FROM (INPUT)	TO (OUTPUT)	V _{CC} = 4.5 V to 5.5 V, C _L = 50 pF, R ₁ = 500 Ω, R ₂ = 500 Ω, T _A = MIN to MAX [§]				UNIT
			SN54AS576		SN74AS576		
			MIN	MAX	MIN	MAX	
f _{max} [*]			100		125	MHz	
t _{PLH}	CLK	Any \bar{Q}	3	11	3	8	ns
t _{PHL}			4	11	4	9	
t _{PZH}	\bar{OE}	Any \bar{Q}	2	7	2	6	ns
t _{PZL}			3	11	3	10	
t _{PHZ}	\bar{OE}	Any \bar{Q}	2	7	2	6	ns
t _{PLZ}			2	7	2	6	

* On products compliant to MIL-STD-883, Class B, this parameter is based on characterization data but is not production tested.

§ For conditions shown as MIN or MAX, use the appropriate value specified under recommended operating conditions.



POST OFFICE BOX 655303 • DALLAS, TEXAS 75265

SN54ALS576B, SN54AS576
SN74ALS576B, SN74ALS577A, SN74AS576

OCTAL D-TYPE EDGE-TRIGGERED FLIP-FLOPS WITH 3-STATE OUTPUTS

SDAS065B - DECEMBER 1982 - REVISED JANUARY 1995

PARAMETER MEASUREMENT INFORMATION SERIES 54ALS/74ALS AND 54AS/74AS DEVICES

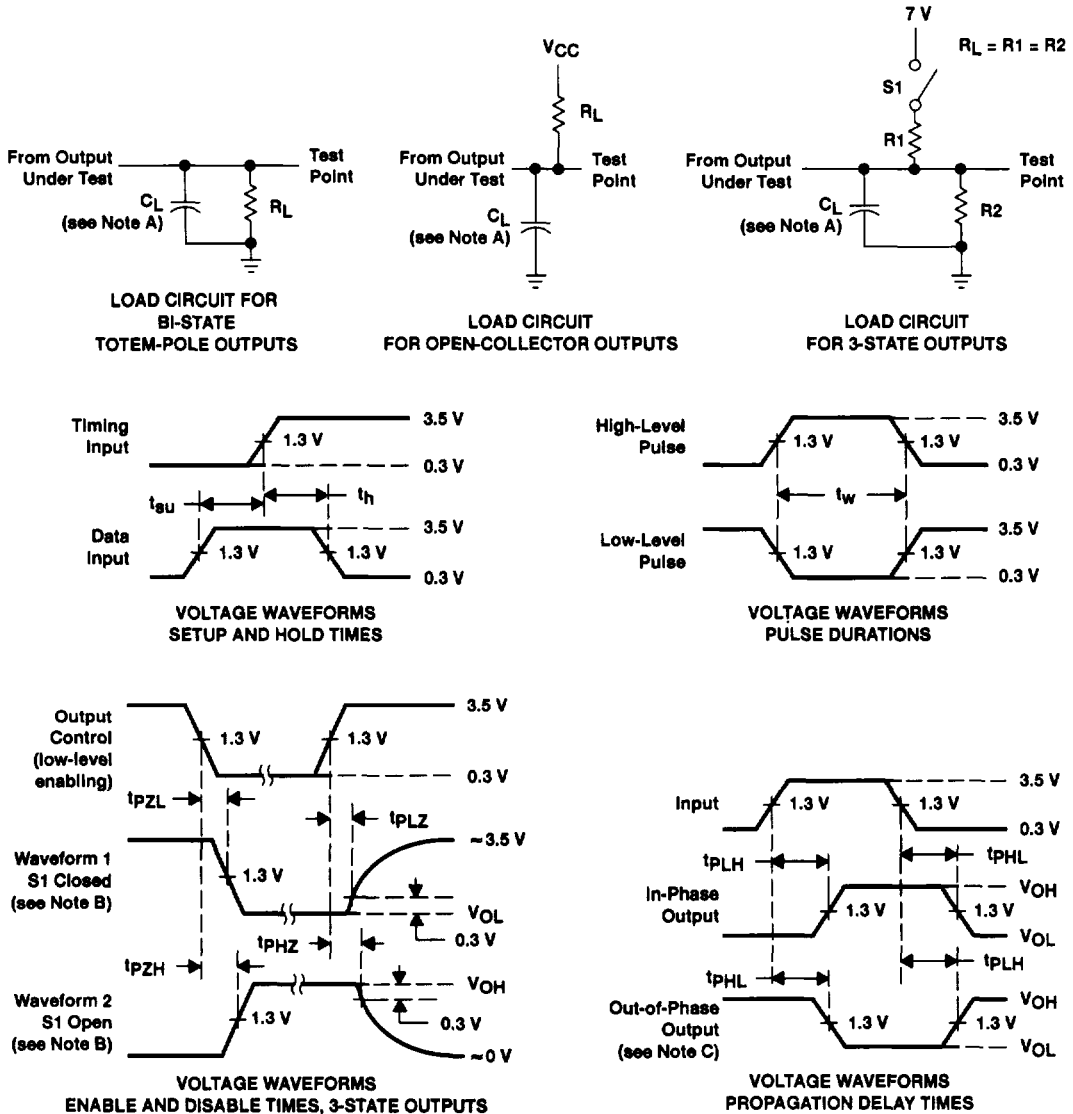

- NOTES:
- A. C_L includes probe and jig capacitance.
 - B. Waveform 1 is for an output with internal conditions such that the output is low except when disabled by the output control. Waveform 2 is for an output with internal conditions such that the output is high except when disabled by the output control.
 - C. When measuring propagation delay items of 3-state outputs, switch S1 is open.
 - D. All input pulses have the following characteristics: $PRR \leq 1$ MHz, $t_r = t_f = 2$ ns, duty cycle = 50%.
 - E. The outputs are measured one at a time with one transition per measurement.

Figure 1. Load Circuits and Voltage Waveforms



POST OFFICE BOX 655303 • DALLAS, TEXAS 75265