



Integrated Device Technology, Inc.

FAST CMOS BUS INTERFACE LATCHES

IDT54/74FCT841AT/BT/CT/DT

FEATURES:

• Common features:

- Low input and output leakage $\leq 1\mu\text{A}$ (max.)
- Extended commercial range of -40°C to $+85^\circ\text{C}$
- CMOS power levels
- True TTL input and output compatibility
 - $V_{OH} = 3.3\text{V}$ (typ.)
 - $V_{OL} = 0.3\text{V}$ (typ.)
- Meets or exceeds JEDEC standard 18 specifications
- Product available in Radiation Tolerant and Radiation Enhanced versions
- Military product compliant to MIL-STD-883, Class B and DESC listed (dual marked)
- Available in DIP, SOIC, SSOP, QSOP, CERPACK and LCC packages

• Features for FCT841T:

- A, B, C and D speed grades
- High drive outputs (-15mA IOH, 48mA IOL)
- Power off disable outputs permit "live insertion"

DESCRIPTION:

The FCT8xxT series is built using an advanced dual metal CMOS technology.

The FCT8xxT bus interface latches are designed to eliminate the extra packages required to buffer existing latches and provide extra data width for wider address/data paths or buses carrying parity. The FCT841T are buffered, 10-bit wide versions of the popular FCT373T function. They are ideal for use as an output port requiring high IOH/IOH.

All of the FCT8xxT high-performance interface family can drive large capacitive loads, while providing low-capacitance bus loading at both inputs and outputs. All inputs have clamp diodes to ground and all outputs are designed for low-capacitance bus loading in high-impedance state.

FUNCTIONAL BLOCK DIAGRAM

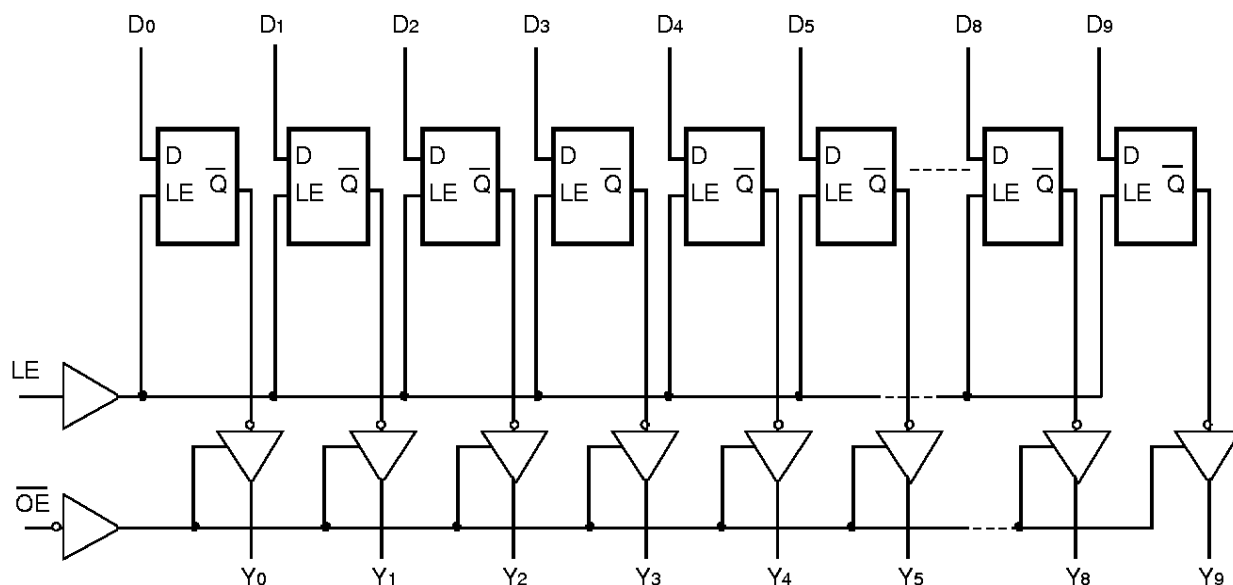

2571 drw 01

The IDT logo is a registered trademark of Integrated Device Technology, Inc.

MILITARY AND INDUSTRIAL TEMPERATURE RANGES

SEPTEMBER 1996

©1997 Integrated Device Technology, Inc.

6.21

For the latest information regarding this part, please contact IDT's web site at <http://www.idt.com> or fax-on-demand service at (US)1-800-9-IDT-FAX / (International) 408-492-8391.

DSC-2571/7

1

PIN CONFIGURATIONS

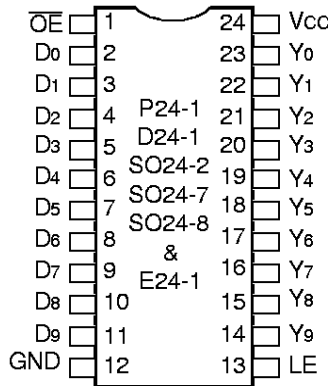

DIP/SOIC/SSOP/QSOP/CERPACK
TOP VIEW

2571 drw 02

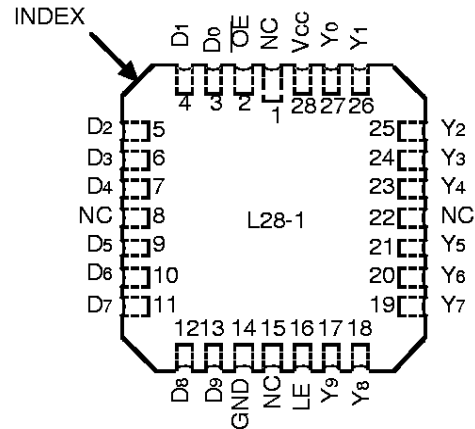

LCC
TOP VIEW

2571 drw 03

PIN DESCRIPTION

Name	I/O	Description
Di	I	The latch data inputs.
LE	I	The latch enable input. The latches are transparent when LE is HIGH. Input data is latched on the HIGH-to-LOW transition.
Yi	O	The 3-state latch outputs.
OE	I	The output enable control. When OE is LOW, the outputs are enabled. When OE is HIGH, the outputs Yi are in high-impedance (off) state.

2571 tbl 01

FUNCTION TABLE⁽¹⁾

Inputs			Internal	Output	Function
OE	LE	Di	Qi	Yi	
H	H	L	L	Z	High Z
H	H	H	H	Z	High Z
H	L	X	NC	Z	Latched (High Z)
L	H	L	L	L	Transparent
L	H	H	H	H	Transparent
L	L	X	NC	NC	Latched

NOTE:

2571 tbl 02

1. H = HIGH, L = LOW, X = Don't Care, NC = No Change, Z = High Impedance

ABSOLUTE MAXIMUM RATINGS⁽¹⁾

Symbol	Description	Max.	Unit
VTERM ⁽²⁾	Terminal Voltage with Respect to GND	-0.5 to +7.0	V
VTERM ⁽³⁾	Terminal Voltage with Respect to GND	-0.5 to Vcc +0.5	V
TSTG	Storage Temperature	-65 to +150	°C
IOUT	DC Output Current	-60 to +120	mA

NOTES:

2571 lnk 03

- Stresses greater than those listed under ABSOLUTE MAXIMUM RATINGS may cause permanent damage to the device. This is a stress rating only and functional operation of the device at these or any other conditions above those indicated in the operational sections of this specification is not implied. Exposure to absolute maximum rating conditions for extended periods may affect reliability. No terminal voltage may exceed Vcc by +0.5V unless otherwise noted.
- Input and Vcc terminals only.
- Outputs and I/O terminals only.

CAPACITANCE (TA = +25°C, f = 1.0MHz)

Symbol	Parameter ⁽¹⁾	Conditions	Typ.	Max.	Unit
CIN	Input Capacitance	VIN = 0V	6	10	pF
COUT	Output Capacitance	VOUT = 0V	8	12	pF

NOTE:

2571 lnk 04

1. This parameter is measured at characterization but not tested.

DC ELECTRICAL CHARACTERISTICS OVER OPERATING RANGE

Following Conditions Apply Unless Otherwise Specified:

Commercial: $T_A = -40^{\circ}\text{C}$ to $+85^{\circ}\text{C}$, $V_{CC} = 5.0\text{V} \pm 5\%$; Military: $T_A = -55^{\circ}\text{C}$ to $+125^{\circ}\text{C}$, $V_{CC} = 5.0\text{V} \pm 10\%$

Symbol	Parameter	Test Conditions ⁽¹⁾		Min.	Typ. ⁽²⁾	Max.	Unit
V_{IH}	Input HIGH Level	Guaranteed Logic HIGH Level		2.0	—	—	V
V_{IL}	Input LOW Level	Guaranteed Logic LOW Level		—	—	0.8	V
I_{IH}	Input HIGH Current ⁽⁴⁾	$V_{CC} = \text{Max.}$	$V_I = 2.7\text{V}$	—	—	± 1	μA
I_{IL}	Input LOW Current ⁽⁴⁾		$V_I = 0.5\text{V}$	—	—	± 1	
I_{OZH}	High Impedance Output Current (3-State Output pins) ⁽⁴⁾	$V_{CC} = \text{Max.}$	$V_O = 2.7\text{V}$	—	—	± 1	μA
I_{OZL}			$V_O = 0.5\text{V}$	—	—	± 1	
I_I	Input HIGH Current ⁽⁴⁾	$V_{CC} = \text{Max.}, V_I = V_{CC} (\text{Max.})$		—	—	± 1	μA
V_{IK}	Clamp Diode Voltage	$V_{CC} = \text{Min.}, I_{IN} = -18\text{mA}$		—	-0.7	-1.2	V
V_H	Input Hysteresis	—		—	200	—	mV
I_{CC}	Quiescent Power Supply Current	$V_{CC} = \text{Max.}, V_{IN} = \text{GND or } V_{CC}$		—	0.01	1	mA

2571 Ink 05

OUTPUT DRIVE CHARACTERISTICS FOR FCT841T

Symbol	Parameter	Test Conditions ⁽¹⁾		Min.	Typ. ⁽²⁾	Max.	Unit
V_{OH}	Output HIGH Voltage	$V_{CC} = \text{Min.}$ $V_{IN} = V_{IH} \text{ or } V_{IL}$	$I_{OH} = -6\text{mA MIL.}$	2.4	3.3	—	V
			$I_{OH} = -8\text{mA COM'L.}$	—	—	—	—
			$I_{OH} = -12\text{mA MIL.}$ $I_{OH} = -15\text{mA COM'L.}$	2.0	3.0	—	V
V_{OL}	Output LOW Voltage	$V_{CC} = \text{Min.}$ $V_{IN} = V_{IH} \text{ or } V_{IL}$	$I_{OL} = 32\text{mA MIL.}$ $I_{OL} = 48\text{mA COM'L.}$	—	0.3	0.5	V
I_{OS}	Short Circuit Current	$V_{CC} = \text{Max.}, V_O = \text{GND}^{(3)}$		-60	-120	-225	mA
I_{OFF}	Input/Output Power Off Leakage ⁽⁵⁾	$V_{CC} = 0\text{V}, V_{IN} \text{ or } V_O \leq 4.5\text{V}$		—	—	± 1	μA

2571 Ink 06

NOTES:

- For conditions shown as Max. or Min., use appropriate value specified under Electrical Characteristics for the applicable device type.
- Typical values are at $V_{CC} = 5.0\text{V}$, $+25^{\circ}\text{C}$ ambient.
- Not more than one output should be shorted at one time. Duration of the short circuit test should not exceed one second.
- The test limit for this parameter is $\pm 5\mu\text{A}$ at $T_A = -55^{\circ}\text{C}$.
- This parameter is guaranteed but not tested.

POWER SUPPLY CHARACTERISTICS

Symbol	Parameter	Test Conditions ⁽¹⁾		Min.	Typ. ⁽²⁾	Max.	Unit
ΔI_{CC}	Quiescent Power Supply Current TTL Inputs HIGH	$V_{CC} = \text{Max.}$ $V_{IN} = 3.4V^{(3)}$		—	0.5	2.0	mA
I_{CCD}	Dynamic Power Supply Current ⁽⁴⁾	$V_{CC} = \text{Max.}$ Outputs Open $\overline{OE} = \text{GND}$ $LE = V_{CC}$ One Input Toggling 50% Duty Cycle	$V_{IN} = V_{CC}$ $V_{IN} = \text{GND}$	—	0.15	0.25	mA/ MHz
I_C	Total Power Supply Current ⁽⁶⁾	$V_{CC} = \text{Max.}$ Outputs Open $f_i = 10\text{MHz}$ 50% Duty Cycle $\overline{OE} = \text{GND}$ $LE = V_{CC}$ One Bit Toggling	$V_{IN} = V_{CC}$ $V_{IN} = \text{GND}$	—	1.5	3.5	mA
			$V_{IN} = 3.4$ $V_{IN} = \text{GND}$	—	1.8	4.5	
		$V_{CC} = \text{Max.}$ Outputs Open $f_i = 2.5\text{MHz}$ 50% Duty Cycle $\overline{OE} = \text{GND}$ $LE = V_{CC}$ Eight Bits Toggling	$V_{IN} = V_{CC}$ $V_{IN} = \text{GND}$	—	3.0	6.0 ⁽⁵⁾	
			$V_{IN} = 3.4$ $V_{IN} = \text{GND}$	—	5.0	14.0 ⁽⁵⁾	

2571 tbl 07

NOTES:

- For conditions shown as Max. or Min., use appropriate value specified under Electrical Characteristics for the applicable device type.
- Typical values are at $V_{CC} = 5.0V$, $+25^\circ\text{C}$ ambient.
- Per TTL driven input ($V_{IN} = 3.4V$). All other inputs at V_{CC} or GND .
- This parameter is not directly testable, but is derived for use in Total Power Supply Calculations.
- Values for these conditions are examples of the I_{CC} formula. These limits are guaranteed but not tested.
- $I_C = I_{QUIESCENT} + I_{INPUTS} + I_{DYNAMIC}$
 $I_C = I_{CC} + \Delta I_{CC} \text{DHNT} + I_{CCD} (f_{CP}/2 + f_i N_i)$
 $I_{CC} = \text{Quiescent Current}$
 $\Delta I_{CC} = \text{Power Supply Current for a TTL High Input } (V_{IN} = 3.4V)$
 $\text{DH} = \text{Duty Cycle for TTL Inputs High}$
 $\text{NT} = \text{Number of TTL Inputs at DH}$
 $I_{CCD} = \text{Dynamic Current Caused by an Input Transition Pair (HLH or LHL)}$
 $f_{CP} = \text{Clock Frequency for Register Devices (Zero for Non-Register Devices)}$
 $f_i = \text{Input Frequency}$
 $N_i = \text{Number of Inputs at } f_i$
 All currents are in milliamps and all frequencies are in megahertz.

SWITCHING CHARACTERISTICS OVER OPERATING RANGE

Symbol	Parameter	Conditions ⁽¹⁾	FCT841AT				FCT841BT				Unit
			Com'l.		Mil.		Com'l.		Mil.		
			Min. ⁽²⁾	Max.	Min. ⁽²⁾	Max.	Min. ⁽²⁾	Max.	Min. ⁽²⁾	Max.	
tPLH tPHL	Propagation Delay DI to Yi (LE = HIGH)	CL = 50pF RL = 500Ω	1.5	9.0	1.5	10.0	1.5	6.5	1.5	7.5	ns
		CL = 300pF ⁽⁴⁾ RL = 500Ω	1.5	13.0	1.5	15.0	1.5	13.0	1.5	15.0	
tPLH tPHL	Propagation Delay LE to Yi	CL = 50pF RL = 500Ω	1.5	12.0	1.5	13.0	1.5	8.0	1.5	10.5	ns
		CL = 300pF ⁽⁴⁾ RL = 500Ω	1.5	16.0	1.5	20.0	1.5	15.5	1.5	18.0	
tPZH tPZL	Output Enable Time \overline{OE} to Yi	CL = 50pF RL = 500Ω	1.5	11.5	1.5	13.0	1.5	8.0	1.5	8.5	ns
		CL = 300pF ⁽⁴⁾ RL = 500Ω	1.5	23.0	1.5	25.0	1.5	14.0	1.5	15.0	
tPHZ tPLZ	Output Disable Time \overline{OE} to Yi	CL = 5pF ⁽⁴⁾ RL = 500Ω	1.5	7.0	1.5	9.0	1.5	6.0	1.5	6.5	ns
		CL = 50pF RL = 500Ω	1.5	8.0	1.5	10.0	1.5	7.0	1.5	7.5	
tSU	Data to LE Set-up Time	CL = 50pF	2.5	—	2.5	—	2.5	—	2.5	—	ns
tH	Data to LE Hold Time	RL = 500Ω	2.5	—	3.0	—	2.5	—	2.5	—	ns
tW	LE Pulse Width HIGH ⁽³⁾		4.0	—	5.0	—	4.0	—	4.0	—	ns

NOTES:

1. See test circuit and waveforms.
2. Minimum limits are guaranteed but not tested on Propagation Delays.
3. These parameters are guaranteed but not tested.
4. These conditions are guaranteed but not tested.

2571 tbl 08

SWITCHING CHARACTERISTICS OVER OPERATING RANGE

Symbol	Parameter	Conditions ⁽¹⁾	FCT841CT				FCT841DT				Unit
			Com'l.		Mil.		Com'l.		Mil.		
			Min. ⁽²⁾	Max.	Min. ⁽²⁾	Max.	Min. ⁽²⁾	Max.	Min. ⁽²⁾	Max.	
tPLH tPHL	Propagation Delay DI to Yi (LE = HIGH)	CL = 50pF RL = 500Ω	1.5	5.5	1.5	6.3	1.5	4.2	—	—	ns
		CL = 300pF ⁽⁴⁾ RL = 500Ω	1.5	13.0	1.5	15.0	1.5	8.0	—	—	
tPLH tPHL	Propagation Delay LE to Yi	CL = 50pF RL = 500Ω	1.5	6.4	1.5	6.8	1.5	4.0	—	—	ns
		CL = 300pF ⁽⁴⁾ RL = 500Ω	1.5	15.0	1.5	16.0	1.5	8.0	—	—	
tPZH tPZL	Output Enable Time \overline{OE} to Yi	CL = 50pF RL = 500Ω	1.5	6.5	1.5	7.3	1.5	4.8	—	—	ns
		CL = 300pF ⁽⁴⁾ RL = 500Ω	1.5	12.0	1.5	13.0	1.5	9.0	—	—	
tPHZ tPLZ	Output Disable Time \overline{OE} to Yi	CL = 5pF ⁽⁴⁾ RL = 500Ω	1.5	5.7	1.5	6.0	1.5	4.0	—	—	ns
		CL = 50pF RL = 500Ω	1.5	6.0	1.5	6.3	1.5	4.0	—	—	
tSU	Data to LE Set-up Time	CL = 50pF	2.5	—	2.5	—	1.5	—	—	—	ns
tH	Data to LE Hold Time	RL = 500Ω	2.5	—	2.5	—	1.0	—	—	—	ns
tW	LE Pulse Width HIGH ⁽³⁾		4.0	—	4.0	—	3.0	—	—	—	ns

NOTES:

1. See test circuit and waveforms.
2. Minimum limits are guaranteed but not tested on Propagation Delays.
3. These parameters are guaranteed but not tested.
4. These conditions are guaranteed but not tested.

2571 tbl 09

TEST CIRCUITS AND WAVEFORMS

TEST CIRCUITS FOR ALL OUTPUTS

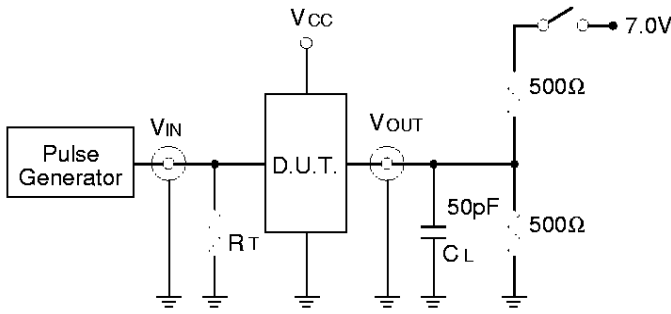

2571 drw 04

SWITCH POSITION

Test	Switch
Open Drain Disable Low Enable Low	Closed
All Other Tests	Open

DEFINITIONS: 2571 lnk 11

CL = Load capacitance: includes jig and probe capacitance.
RT = Termination resistance: should be equal to ZOUT of the Pulse Generator.

SET-UP, HOLD AND RELEASE TIMES

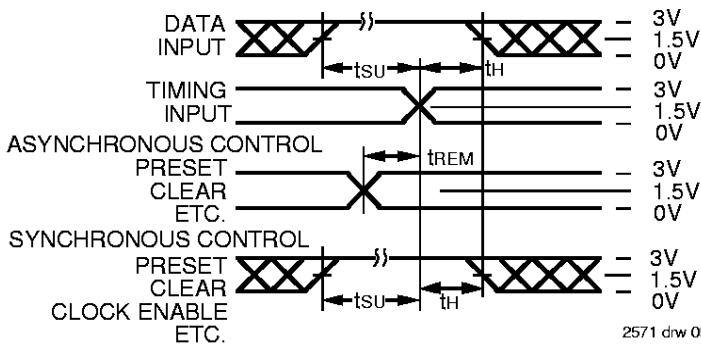

2571 drw 05

PULSE WIDTH

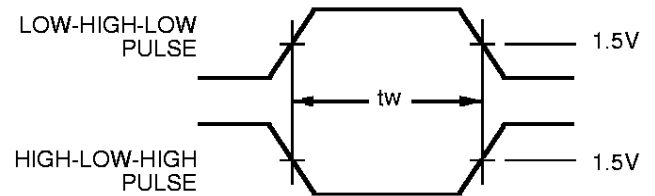

2571 drw 06

PROPAGATION DELAY

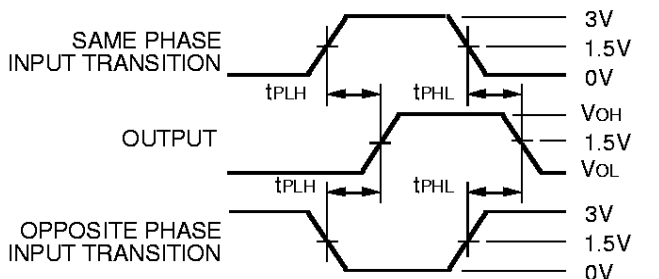

2571 drw 07

ENABLE AND DISABLE TIMES

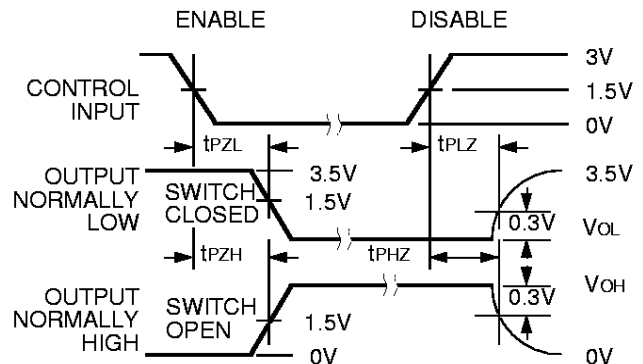

2571 drw 08

NOTES:

- Diagram shown for input Control Enable-LOW and input Control Disable-HIGH
- Pulse Generator for All Pulses: Rate $\leq 1.0\text{MHz}$; $t_f \leq 2.5\text{ns}$; $t_r \leq 2.5\text{ns}$

ORDERING INFORMATION

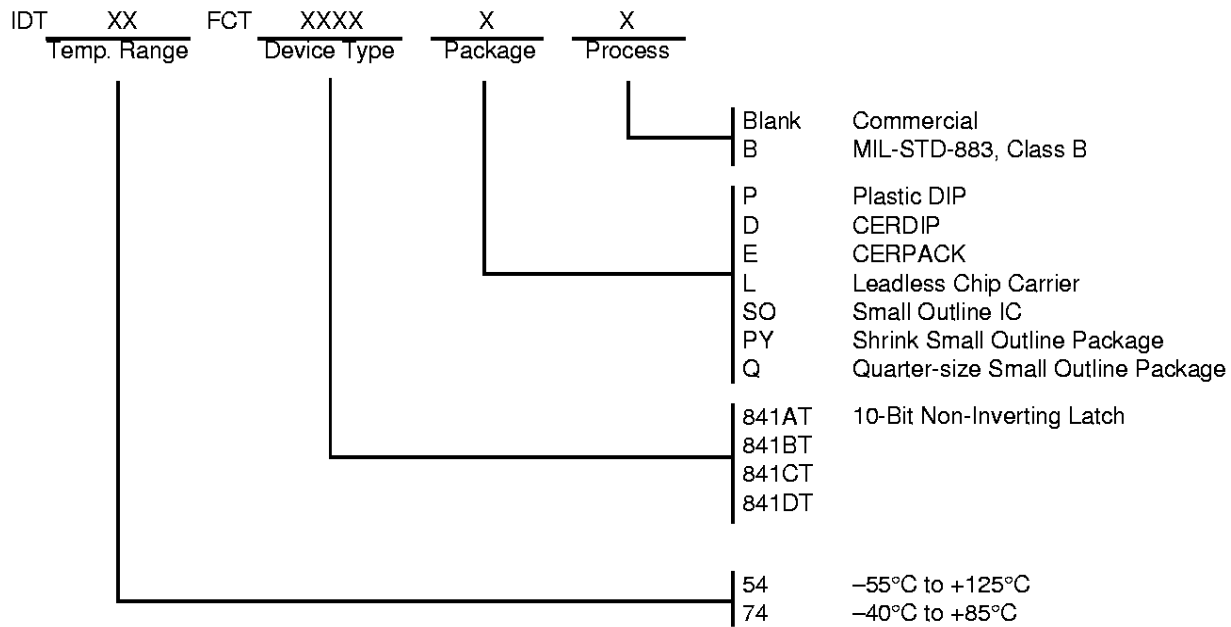

2571 drw 09