

# RC5036

## Dual Adjustable Voltage Regulators w/Enable

### Features

- Combines switching regulator and low dropout linear regulator in single chip
- Pentium® P54C/P55C CPU selectable – no jumpers required
- Linear regulator on/off control
- Each output voltage adjustable from 1.5V to 3.6V
- Built-in soft start
- Switcher can be configured for 13A loads, linear for 5A
- Precision trimmed low TC voltage reference
- “Constant On-Time” oscillator (patent pending)
- Small footprint 16 lead SOIC package

### Applications

- Switchable single/dual power supply for Pentium P54C/P55C flexible motherboard implementation
- Dual 3.3V/2.xV or 3.xV power supply for Intel Pentium MMX™ and AMD-K6™ MMX and Cyrix 6x86MX™ (M2) processors requiring separate voltage planes
- Programmable dual power supply for high current loads

### Description

The RC5036 combines a switch-mode DC-DC converter with a low-dropout linear regulator. In addition, it integrates the circuitry required to switch the DC-DC converter output between 3.5V and a user-selectable voltage from 1.5V to 3.6V as well as an enable function to allow the linear regulator to be turned off when not required. RC5036 has built-in Soft Start feature which offers system protection during power-up by reducing both inrush current and output overshoot. Using minimal external components, the RC5036 can be configured to directly implement the two supply situations required in a P54/P55 and K6 flexible motherboard application. In one mode, the DC-DC converter provides the 3.5V VRE level required by the P54 processor. The linear regulator can be disabled or can provide 3.3V for peripheral components. Using the *VCC2DET* pin from the P55C processor, the RC5036 can be automatically reconfigured to provide a 2.xV or 3.xV CPU core supply from the DC-DC converter and a 3.3V I/O supply from the linear regulator.

With the appropriate external components, the DC-DC converter can deliver load current as high as 13A and the linear regulator can provide 5A. The DC-DC converter and the linear regulator can be set independently using two external resistors each to any value between 1.5V and 3.6V. The factory trimmed internal reference achieves tight tolerance voltage regulation on both outputs. Independent short circuit protection is also provided.

### Block Diagram

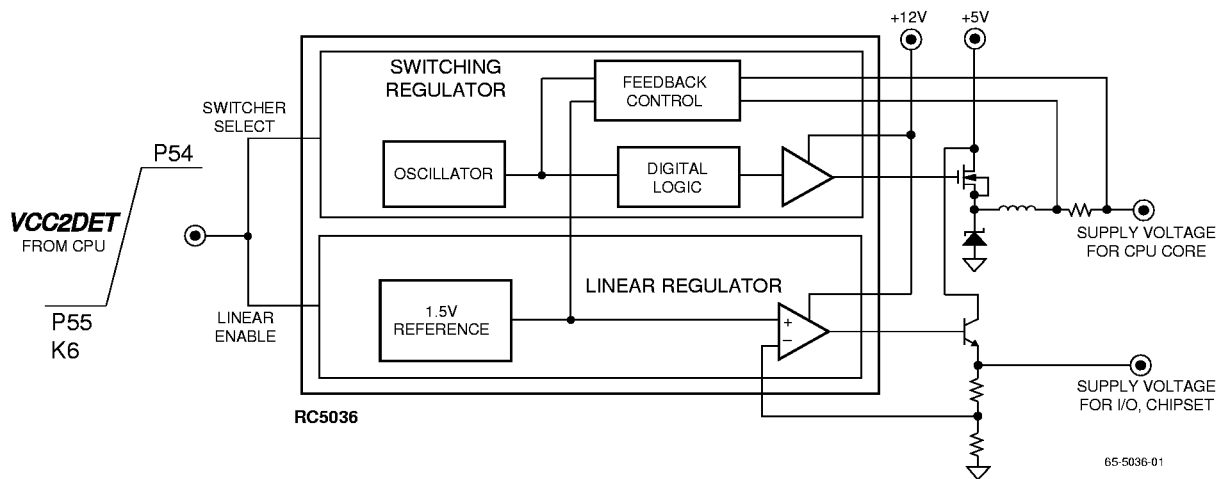

Pentium is a registered trademark of Intel Corporation.  
MMX is a trademark of Intel Corporation.  
K6 is a trademark of AMD Corporation.  
6x86MX is a trademark of Cyrix Corporation.

## Functional Description

The RC5036 contains a precision trimmed zero TC voltage reference, a constant-on-time architecture controller, a high current switcher output driver, a low offset op-amp, and switches for selecting various output modes. The block diagram in Figure 1 shows how the RC5036 in combination with the external components achieves a switchable dual power supply.

### Switch-Mode Control Loop

The main control loop for the switch-mode converter consists of a current conditioning amplifier and one of the two voltage conditioning amplifiers that take the raw voltage and current information from the regulator output, compare them against the precision reference and present the error signal to the input of the constant-on-time oscillator. The two voltage conditioning amplifiers act as an analog switch to select between the internal resistor divider network (set for 3.5V) or an external resistor divider network (adjustable for 1.5V to 3.6V.) The switch-mode select pin determines which of the two amplifiers is selected. The current feedback signals come across the Iout sense resistor to the IFBH and IFBL inputs of the RC5036. The error signals from both the current feedback loop and the voltage feedback loop are summed together and used to control the off-time duration of the oscillator. The current feedback error signal is also used as part of the RC5036 short-circuit protection.

### Linear Control Loop

The low-offset op-amp is configured to be the controlling element in a precision low-drop-out linear regulator. As can

be seen from Figure 1, the op-amp is used to compare the divided down output of the linear regulator to the precision reference. The error signal is used to control either an N-channel MOSFET or a power NPN transistor.

### High Current Output Drivers

The RC5036 switching high current output driver (SDRV) contains high speed bipolar power transistors configured in a push-pull configuration. The output driver is capable of supplying 0.5A of current in less than 100ns. The driver's power and ground are separated from the overall chip power and ground for added switching noise immunity.

### Internal Reference

The reference in the RC5036 is a precision band-gap type reference. Its temperature coefficient is trimmed to provide a near zero TC. For guaranteed stable operation under all loading conditions, a 0.1µF capacitor is recommended on the VREF output pin.

### Constant-On-Time Oscillator

The RC5036 switch-mode oscillator is designed as a fixed on-time, variable off-time oscillator. The constant-on-time oscillator consists of a comparator, an external capacitor, a fixed current source, a variable current source, and an analog switch that selects between two threshold voltages for the comparator. The external timing capacitor is alternately charged and discharged through the enabling and disabling of the fixed current source. The variable current source is controlled from the error inputs that are received from the current and voltage feedback signals. The oscillator off-time

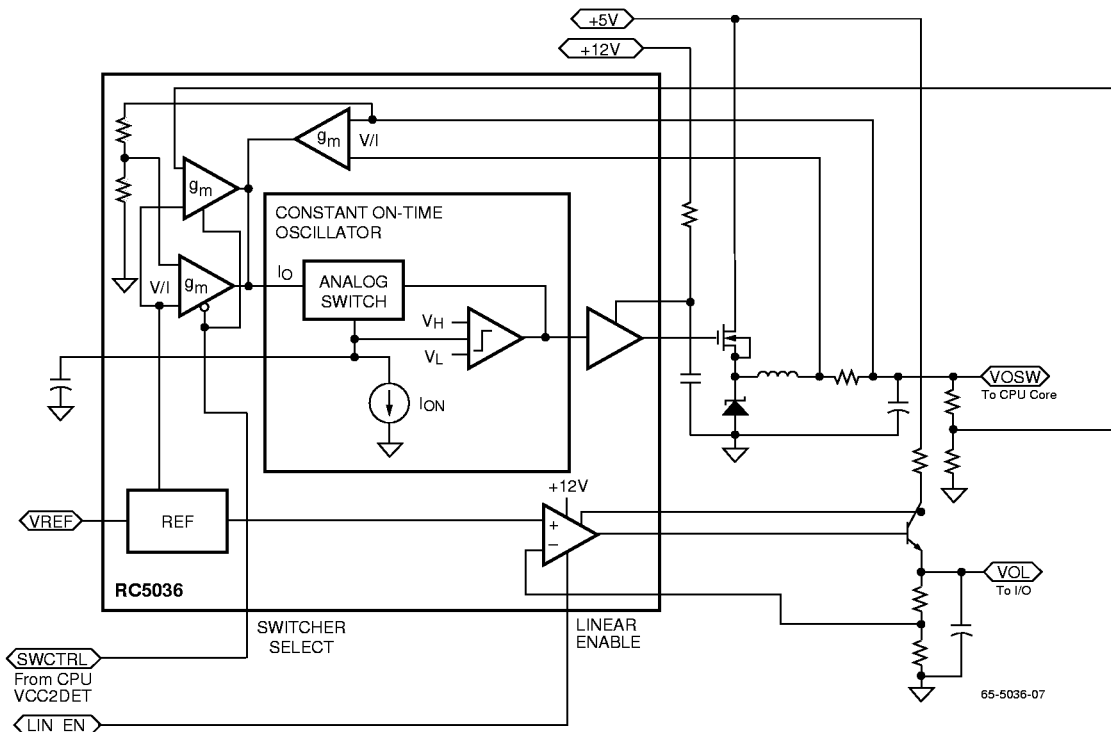

Figure 1. RC5036 Block Diagram

is controlled by the amount of current that is available from the variable current source to charge the external capacitor up to the high threshold level of the comparator. The on-time is set by the constant current source that discharges the external capacitor voltage down to the lower comparator threshold.

### Using Intel's VCC2DET pin

Intel has specified a logic pin on both the P54 and P55C Pentium processors in order to simplify the task of designing a “flexible motherboard” that can accept both varieties of CPU. This pin (VCC2DET) is located at position AL1, and is internally bonded to ground on the P55C and left unconnected on the P54 and its equivalents. The RC5036 has two

logic inputs (SWCTRL and LIN\_EN) that can read this CPU pin directly and set each of its two outputs accordingly.

When the SWCTRL pin is HIGH, the switching regulator will set its output at 3.5V using two internal precision resistors. When this pin is LOW, the switching regulator output can be set to any voltage between 1.5V and 3.6V using external precision resistors. The LIN\_EN pin is used to enable or disable the linear regulator. When the LIN\_EN pin is HIGH, the linear regulator will be disabled. If this pin is LOW, the linear regulator output can be set from 1.5V to 3.5V using external precision resistors. The linear regulator output can be left on to provide power to other 3.3V components such as SRAM, DRAM and I/O chipset.

## Pin Assignments

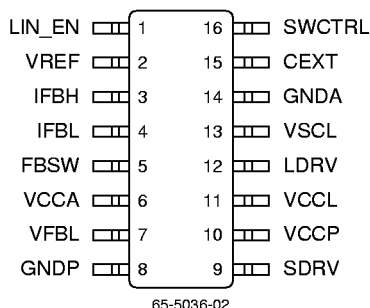

## Pin Descriptions

Pin Name	Pin Number	Pin Function Description
LIN_EN	1	<b>Linear regulator enable input.</b> Accepts TTL/open collector input levels. A logic level HIGH on this pin disables the output of the linear regulator, pin 12. For P54/P55 applications, this pin should be connected to the VCC2DET processor pin (located at CPU pin position AL1).
VREF	2	<b>Voltage reference test point.</b> This pin provides access to the internal precision 1.5V bandgap reference and should be decoupled to ground using a 0.1µF ceramic capacitor. No load should be connected to this pin.
IFBH	3	<b>High side current feedback for switching regulator.</b> Pins 3 and 4 are used as the inputs for the current feedback control loop and as the short circuit current sense points. Careful layout of the traces from these pins to the current sense resistor is critical for optimal performance of the short circuit protection scheme. See Applications Discussion for details.
IFBL	4	<b>Low side current feedback for switching regulator.</b> See Applications Discussion for details.
FBSW	5	<b>Voltage feedback for switching regulator.</b> This input is active when a logic level LOW is input on pin 16 (SWCTRL). Using two external resistors, it sets the output voltage level for the switching regulator. See Applications Discussion for details.
VCCA	6	<b>Switching Regulator V<sub>cc</sub>.</b> Power supply for switching regulator control circuitry and voltage reference. Connect to system 5V supply and decouple to ground with 0.1µF ceramic capacitor.
VFBL	7	<b>Voltage feedback for linear regulator.</b> Using two external resistors, this pin sets the output voltage level for the linear regulator. See Applications Discussion for details.

## Pin Descriptions (continued)

Pin Name	Pin Number	Pin Function Description
GNDP	8	<b>Power Ground.</b> Return pin for high currents flowing in pins 9, 10 and 12 (SDRV, VCCP and LDRV). Connect to a low impedance ground. See Applications Discussion for details.
SDRV	9	<b>FET driver output for switching regulator.</b> Connect this pin to the gate of the N-channel MOSFET M1 as shown in Figure 14. The trace from this pin to the MOSFET gate should be kept as short as possible (less than 0.5"). See Applications Discussion for details.
VCCP	10	<b>Switching regulator gate drive V<sub>CC</sub>.</b> Power supply for SDRV output driver. Connect to system 12V supply with R-C filter shown in Figure 14. See Applications Discussion for details.
VCCL	11	<b>Linear Regulator V<sub>CC</sub>.</b> Power supply for LDRV output op-amp. Connect to system 12V supply and decouple to ground with 0.1 $\mu$ F ceramic capacitor.
LDRV	12	<b>Output driver for linear regulator.</b> Connect this pin to the base of an NPN transistor. When pin 1 (LIN_EN) is pulled HIGH, the linear regulator is disabled and pin 12 will be pulled low internally.
VSCL	13	<b>Low side current sense for linear regulator.</b> Connect this pin between the sense resistor and the collector of the power transistor. The high side current sense is internally connected to pin 6 (VCCA). Layout is critical to optimal performance of the linear regulator short circuit protection scheme. See Applications Discussion for details.
GND A	14	<b>Analog ground.</b> All low power internal circuitry returns to this pin. This pin should be connected to system ground so that ground loops are avoided. See Applications Discussion for details.
CEXT	15	<b>External capacitor.</b> A 180pF capacitor is connected to this pin as part of the constant on-time pulse width circuit. Careful layout of this pin is critical to system performance. See Applications Discussion for details.
SWCTRL	16	<b>Switching regulator control input.</b> Accepts TTL/open collector input levels. A logic level HIGH on this pin presets the switching regulator output voltage at 3.5V using internal resistors. A logic level LOW on this pin will select the output voltage set by two external resistors and the voltage feedback control pin 5 (VFBSW). See Applications Discussion for details.

## Absolute Maximum Ratings

Supply Voltages, VCCA, VCCL, VCCP	13V
Junction Temperature, T <sub>J</sub>	+150°C
Storage Temperature, T <sub>S</sub>	-65 to +150°C
Lead Soldering Temperature, 10 seconds	300°C

### Note:

- Functional operation under any of these conditions is not implied. Performance is guaranteed only if Operating Conditions are not exceeded.

## Operating Conditions

Parameter	Conditions	Min.	Typ.	Max.	Units
Switching Regulator VCC, VCCA		4.75	5	5.25	V
Linear Regulator VCC, VCCL		11.4	12	12.6	V
Logic Inputs, SWCTRL, LIN_EN	Logic HIGH Logic LOW	2.4		0.8	V V
Ambient Operating Temperature, TA		0		70	°C
Drive Gate Supply, VCCP		9	12	13	V

## Electrical Characteristics – Switch-Mode Regulator

(VCCA = 5V, VCCL = 12V, TA = 25°C using circuit of Figure 14, unless otherwise noted)

The • denotes specifications which apply over the full ambient operating temperature range.

Parameter	Conditions	Min.	Typ.	Max.	Units	
Output Voltage, VOSW <sup>1</sup>	SWCTRL = HIGH Set by internal resistors	•	3.5		V	
Output Voltage, VOSW <sup>1</sup>	SWCTRL = LOW Set by external resistors	•	1.5	3.6	V	
Setpoint Accuracy <sup>2</sup>	ISW = 5A		-1.2	+1.2	%Vo	
Output Temperature Drift		•	40		ppm	
Output Current, ISW		•		13	A	
Line Regulation	VCCA = 4.75 to 5.25V ISW = 5A		0.10	0.15	%Vo	
Load Regulation	ISW = 0 to 5A or 5A to 10A		±0.9	±1.3	%Vo	
Output Ripple, peak-peak	20MHz BW, ISW = 5A		15		mV	
Cumulative DC Accuracy <sup>3</sup>		•	±55	±100	mV	
Efficiency	ISW = 5A	•	80	87	%	
Output Driver Current	Open Loop	•	0.5		A	
Short Circuit Threshold Voltage		•	80	90	100	mV
On Time Pulse Width <sup>4</sup>	CEXT = 180pF		3.5		µs	

### Notes:

- When the SWCTRL pin is HIGH or left open, the switch-mode regulator output will be preset at 3.5V using internal precision resistors. When the SWCTRL pin is LOW, the output voltage may be programmed with external resistors. Please refer to the Applications Section for output voltage selection information.
- Setpoint accuracy is the initial output voltage variability under the specified conditions. When SWCTRL is LOW, the matching of the external resistors will have a major influence on this parameter.
- Cumulative DC accuracy includes setpoint accuracy, temperature drift, line and load regulation, and output ripple.
- The on-time pulse width of the oscillator is preset using external capacitor CEXT. See Typical Operating Characteristics curves.

## Electrical Characteristics – Linear Regulator

(VCCA = 5V, VCCL = 12V, TA = 25°C using circuit in Figure 14, unless otherwise noted)

The • denotes specifications which apply over the full ambient operating temperature range.

Parameter	Conditions	Min	Typ	Max	Units
Output Voltage, VOL <sup>1</sup>	Set by external resistors •	1.5		3.6	V
Setpoint Accuracy <sup>2</sup>	IL=0.5A, using 0.1% resistors	-1.5		+1.5	%
Output Temperature Drift	•		40		ppm
Output Current, IL	•			5	A
Line Regulation	VCCL = 11.4V to 12.6V, IL = 3A		0.1	0.15	%Vo
Load Regulation	IL = 0 to 5A		±0.7	±1	%Vo
Output Noise	0.1 to 20KHz		1		mV
Cumulative DC Accuracy <sup>3</sup>	•		±1.7	±3	%
Crosstalk <sup>4</sup>	ISW = 5A		35		mV, p-p
Short Circuit Comparator Threshold	Internal comparator offset •	40	50	60	mV
Op-amp Output Current	Open Loop	50	70		mA

### Notes:

1. When the LIN\_EN pin is LOW, the linear regulator output is set with external resistors. When the LIN\_EN pin is HIGH, the linear regulator is disabled and will exhibit no output voltage. Please refer to the Application Section for output voltage selection information.
2. Setpoint accuracy is the initial output voltage variability under the specified conditions. The matching of the external resistors will have a major influence on this parameter.
3. Cumulative DC accuracy includes setpoint accuracy, temperature drift, line and load regulation.
4. Crosstalk is defined as the amount of switching noise from the switch-mode regulator that appears on the output of the linear regulator when both outputs are in a static load condition.

## Electrical Characteristics – Common

(VCCA = 5V, VCCL = 12V, TA = 25°C using circuit of Figure 14, unless otherwise noted)

The • denotes specifications which apply over the full ambient operating temperature range.

Parameter	Conditions	Min	Typ	Max	Units
Reference Voltage, VREF		1.485	1.5	1.515	V
VREF PSRR		60			dB
Thermal Impedance, $\theta_{JA}$	•		150		°C/W
VCCA Supply Current	Independent of load •		5	10	mA
VCCP Supply Current	ISW = 5A •		20	25	mA
VCCL Supply Current	IL = 2A •		5		mA
Internal Power Dissipation	ISW = 5A, IL = 2A, using Figure 1 •		325		mW

### Typical Operating Characteristics

(VCCA = 5V, VCCL = 12V and TA = +25°C using circuit in Figure 14, unless otherwise noted)

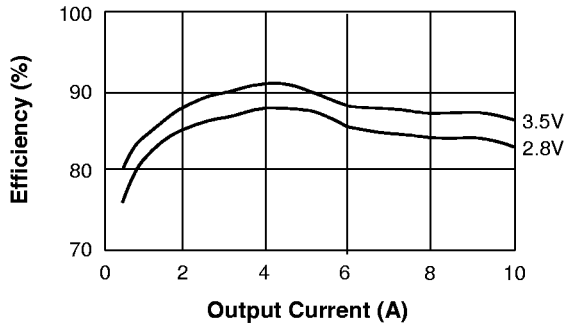

Figure 2. Switcher Efficiency vs. Output Current

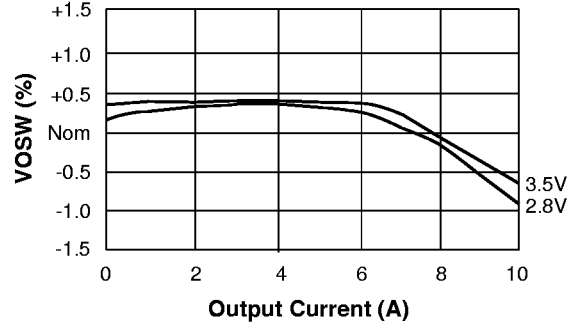

Figure 3. Switcher Output Voltage vs. Load

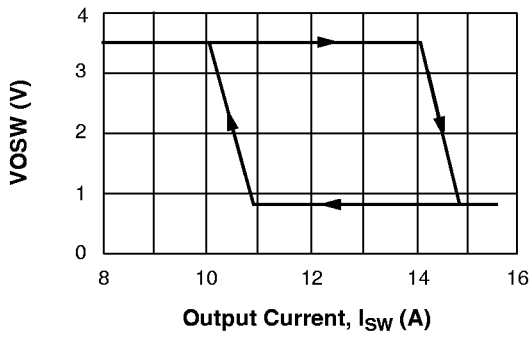

Figure 4. Switcher Output vs Output Current

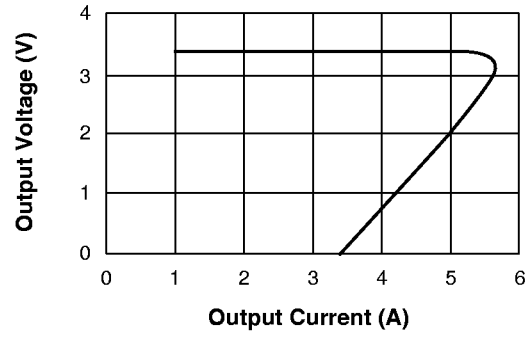

Figure 5. Linear Regulator Shortcircuit Characteristic R<sub>sense</sub> = 7 mΩ

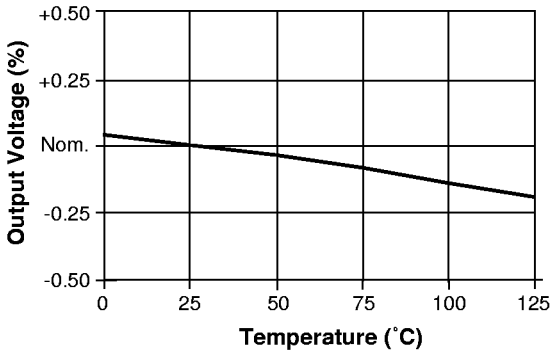

Figure 6. Output Voltage vs. Temperature (ISW or IL = 5A)

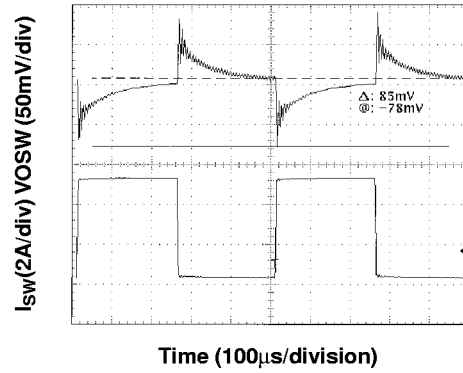

Figure 7. Switcher Transient Response (0.5 to 5.5A Load Step)

# Typical Operating Characteristics (continued)

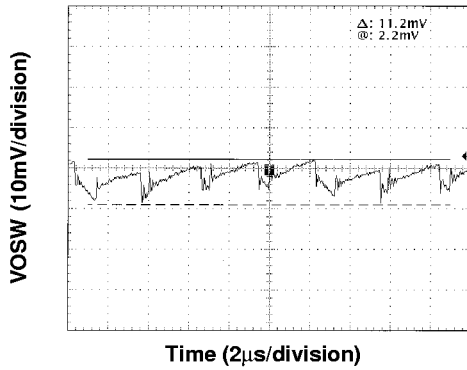

Figure 8. Switcher Output Ripple (BW = 20MHz, I<sub>SW</sub> = 5A)

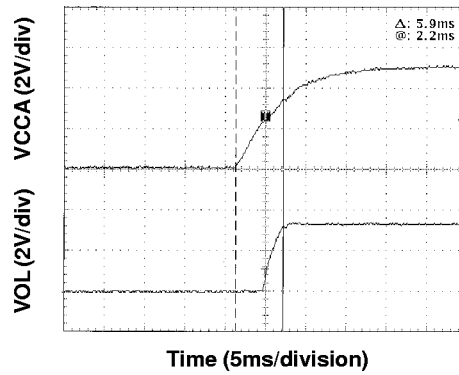

Figure 9. Linear Turn-on Response

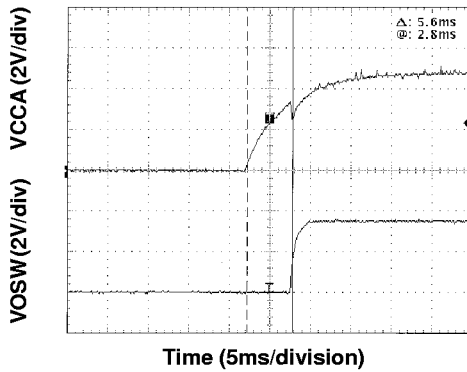

Figure 10. Switcher Turn-on Response

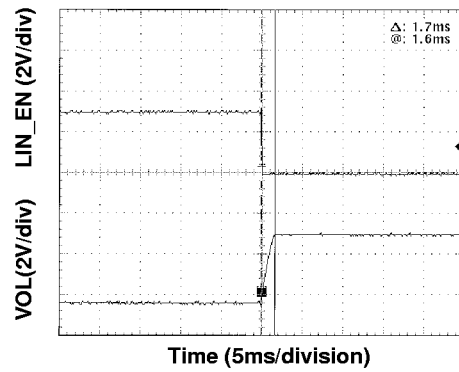

Figure 11. Linear Turn-on Response (using LIN\_EN pin)

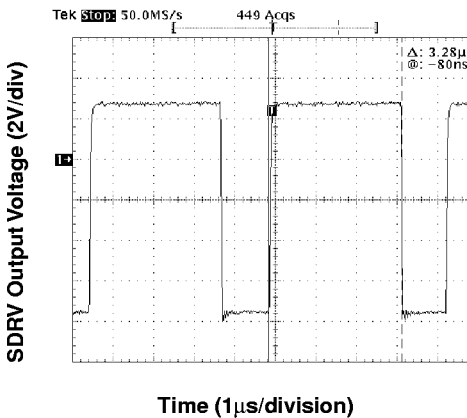

Figure 12. Pin 9 (SDRV) at a 5 Amp Load

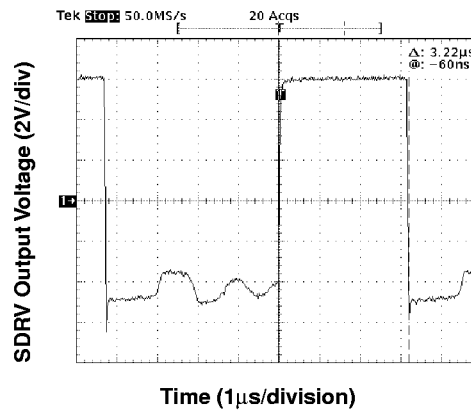
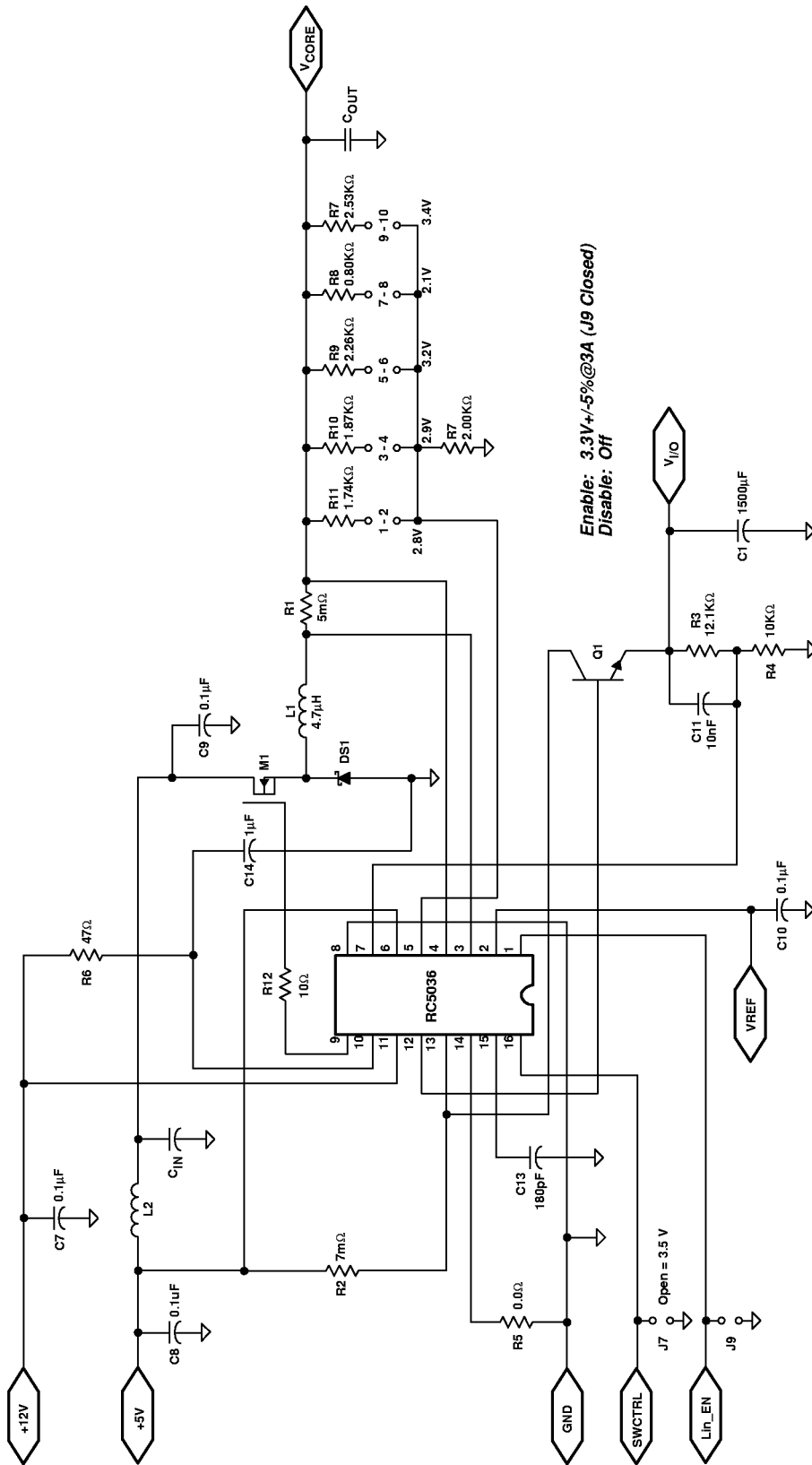

Figure 13. Pin 9 (SDRV) at a 0.1 Amp Load



# Test Circuit Configurations



Enable: 3.3V+/-5%@3A (J9 Closed)  
Disable: Off

Figure 14. P54/P55C, K6, or M2 Single/Dual Power Supply Application Schematic

**Table 1. Bill of Materials for a RC5036 P55C, K6, or M2 Application**

Qty.	Reference	Manufacturer Part Order #	Description	Requirements and Comments
4	C7, C8, C9, C10	Panasonic ECU-V1H104ZFX	0.1 $\mu$ F 50V SMT 0805 capacitors	
1	C11	Panasonic ECU-V1H103KBX	10nF 50V SMT 0805 capacitor	
1	C13	Panasonic ECU-V1H181JCG	180pF 50V SMT0805 capacitor	
1	C14	Panasonic ECSH1CY105R	1 $\mu$ F 16V SMT 0805 Capacitor	
See Table 2	COUT	Sanyo 6MV1500GX	1500 $\mu$ F 6.3V electrolytic capacitor, 10mm x 20mm	ESR < 0.044 $\Omega$
See Table 2	CIN	Sanyo 10MB1200GX	1200 $\mu$ F 10 B electrolytic capacitor, 10mm x 20mm	
1	C1	Sanyo 6MV1500GX	1500 $\mu$ F 6.3V electrolytic capacitor, 10mm x 20mm	
1	DS1	Motorola MBR1545CT	Schottky Diode	$V_f < 0.57V$ at $I_f = 7.5A$
1	L1	Pulse Engineering PE-53682	4.7 $\mu$ H inductor	
1	L2	Beads Inductor	2 Beads, 3.5 x 8mm wire, diameter = 0.6mm	Optional—Helps reduce ripple on the 5V line
1	M1	IRL3103	N-Channel Logic Level Enhancement Mode MOSFET	$R_{DS(ON)} < 20m\Omega$ , $V_{GS} < 4.5V$ , $I_D > 20A$
1	Q1	Motorola MJE15028	NPN power transistor	$\beta > 80$ at 3A
1	R1	RSENSE (SW)	5m $\Omega$ MnCu or Copel resistor	
1	R8	Panasonic ERJ-6ENF 0.80KV	0.80K $\Omega$ 1% resistor	0.1% resistor desirable for accuracy
1	R9	Panasonic ERJ-6ENF2.26KV	2.26K $\Omega$ 1% resistor	0.1% resistor desirable for accuracy
1	R10	Panasonic ERJ-6ENF1.87KV	1.87K $\Omega$ 1% resistor	0.1% resistor desirable for accuracy
1	R11	Panasonic ERJ-6ENF1.74KV	1.74K $\Omega$ 1% resistor	0.1% resistor desirable for accuracy
1	R7	Panasonic ERJ-6ENF2.00KV	2.00K $\Omega$ 1% resistor	0.1% resistor desirable for accuracy
1	R3	Panasonic ERJ-6ENF12.1KV	12.1K $\Omega$ 1% resistor	0.1% resistor desirable for accuracy
1	R4	Panasonic ERJ-6ENF10.0KV	10.0K $\Omega$ 1% resistor	0.1% resistor desirable for accuracy
1	R5	Panasonic ERJ-6GEY000V	0 $\Omega$ 5% resistor	Resistor raises $V_{OUT}$ 25mV/5 $\Omega$
1	R6	Panasonic ERJ-6GEY047V	47 $\Omega$ 5% resistor	
1	R2	RSENSE (Lin)	7m $\Omega$ MnCu or Copel resistor	
1	U1	Raytheon RC5036M	Dual Regulator for P55—switching regulator + LDO linear regulator	

**Table 2. Switching Regulator Components Selection Table**

Output Voltage	Output Current	CIN Sanyo 10MV1200GX	COU Sanyo 6M1500GX	Power MOSFET (M1)
3.5	8	1x	2x	IRL3103
2.8	6	1x	2x	IRL3103
2.9	6.25	1x	2x	IRL3103
2.9	7.5	1x	2x	IRL3103
3.2	9.5	2x	4x	IRL3103
3.2	13	3x	6x	IRL3103
2.1	5.6	1x	2x	IRL3103
3.3	3	N/A	1x	MJE15028

## Applications Discussion

The following discussion is intended to be an abbreviated list of design considerations regarding the RC5036 as used in a typical dual voltage processor motherboard application. For a more thorough discussion of applicable specifications relating to the Intel Pentium P55C processor as well as details on RC5036 design equations, please refer to Application Note 48.

### Output Voltage Selection

#### Feedback Voltage Divider

The RC5036 precision reference is trimmed to be 1.5V nominally. When using the RC5036, the system designer has complete flexibility in choosing the output voltage for each regulator from 1.5V to 3.6V. This is done by appropriately selecting the feedback resistors. These should be 0.1% resistors to realize optimum output accuracy. The following equations determine the output voltages of the two regulators:

Switching Regulator

$$V_{OUT} = 1.5 \times \left( \frac{R2 + R3}{R3} \right)$$

Linear Regulator

$$V_{OUT} = 1.5 \times \left( \frac{R4 + R5}{R5} \right)$$

where  $R2 > 1.5k\Omega$  and  $(R2 + R3) \leq 25k\Omega$  and  $R4 > 1.5k\Omega$  and  $(R4 + R5) \leq 25k\Omega$

Example:

For 2.8V,

$$V_{OUT} = 1.5 \times \left( \frac{R2 + R3}{R3} \right) = 1.5 \times \left( \frac{1.6k + 1.85k}{1.85k} \right) = 2.8V$$

For 3.3V,

$$V_{OUT} = 1.5 \times \left( \frac{R4 + R5}{R5} \right) = 1.5 \times \left( \frac{12.1k + 10k}{10k} \right) = 3.32V$$

### Linear Regulator Design Considerations

Figure 14 shows the application schematic for the RC5036 with a power NPN used for the linear regulator.

Careful consideration must be given to the base current of the power NPN device. The base current to the power NPN device is limited by:

- The RC5036 op-amp output current (50mA)
- The internal power dissipation of the RC5036 package
- The  $\beta$  of the power NPN device.

The internal RC5036 power dissipation is the most severe limitation for this application. For optimum reliability, we require that the junction temperature not exceed 130°C; thus we can calculate the maximum power dissipation allowable for this 16-lead SOIC package as follows:

$$P_D = \frac{T_{J(max)} - T_A}{R_{\theta JA}}$$

If we assume that the ambient temperature  $T_A$  is 50°C and the thermal resistance of the 16-lead SOIC package is 150°C/W, then the maximum power dissipation for the IC is:

$$P_D = \frac{130 - 50}{150} \leq 0.533W$$

$$P_D = P_{SW} + P_{LN} =$$

$$(35mA \times 5.25V) + (12.6V - V_{OUT} - V_{BE}) \times I_{OL} \leq 0.533W$$

Where  $P_{SW}$  is the internal power dissipation of the switching regulator and  $P_{LN}$  is the internal power dissipation of the linear regulator.  $I_{OL}$  is the linear regulator op-amp output current. For  $V_{OUT} = 3.3V$  nominal, the worst case output will be determined by the specific CPU used.

For example, for a worst case  $V_{OUT} = 3.135V$ , the maximum op-amp output current is:

$$I_{OL} = \frac{0.533W - (35mA \times 5.25V)}{(12.6V - 3.135V - 0.8V)} \leq 40mA$$

$$\beta \geq \frac{3000mA}{40mA} = 75$$

The power NPN transistor must have a minimum  $\beta$  of 75 at  $I_L = 3A$  in order to meet the internal power dissipation limit of the 16-SOIC package.

Using a D44H11 power transistor (available from several manufacturers), we find that the minimum  $\beta$  for operation at 3A is around 50 at 25°C. At first glance, we might think that this violates our requirement for  $\beta > 75$ . However, further analysis will show that the  $\beta$  in the actual application will be much higher than 50. We know that the manufacturer's minimum at 25°C is conservative, and that over temperature  $\beta$  increases. If we calculate the junction temperature of the power transistor under a 3A load, we get:

$$P_D = I \times V_{CE} = 3A \times (5 - 3.3) = 5.1W$$

Using the equation from above for obtaining the junction temperature, we have:

$$P_D = \frac{T_{J(max)} - T_A}{R_{\Theta JA}} = 5.1W$$

For a TO-220 package with the appropriate heat sink, the  $\Theta_{JC}$  is about 8°C/W. If we again assume that the ambient temperature is 50°C, then we can solve for  $T_{J(max)}$ .

$$T_{J(max)} = P_D \times R_{\Theta JA} + T_A = 5.1W \times 8 + 50 = 90.8^\circ C$$

At this temperature, the typical  $\beta$  for a D44H11 will be over 90, much higher than the minimum, so that a transistor with a rated  $\beta$  minimum of 50 at 25°C will yield a  $\beta$  well above 75 under typical ambient conditions.

## Short Circuit Considerations

### For the Switch-Mode Regulator

The RC5036 uses a current sensing scheme to limit the load current if an output fault condition occurs. The current sense resistor carries the peak current of the inductor, which is greater than the maximum load current due to ripple currents flowing in the inductor. The RC5036 will begin to limit the output current to the load by turning off the top-side FET driver when the voltage across the current-sense resistor exceeds the short circuit comparator threshold voltage ( $V_{th}$ ). When this happens the output voltage will temporarily go out of regulation. As the voltage across the sense resistor becomes larger, the top-side MOSFET will continue to turn off until the current limit value is reached. At this point, the RC5036 will continuously deliver the limit current at a reduced output voltage level. The short circuit comparator threshold voltage is typically 90mV, with a variability of  $\pm 10mV$ . The ripple current flowing through the inductor is typically 0.5A. There needs to be a 29% margin for the sense resistor when using a motherboard PC trace resistor. Refer to Application Note 48 for detailed discussions. The sense resistor value can be approximated as follows:

$$R_{SENSE} = \frac{V_{th,min}}{I_{PK}} \times (1 - TF) = \frac{V_{th,min}}{1.5A + I_{LOAD,MAX}} \times (1 - TF)$$

Where TF = Tolerance Factor for the sense resistor and 1.5A accounts for the inductor current ripple. Table 3 describes the tolerance, size, power capability, temperature coefficient and cost of various types of sense resistors.

**Table 3. Comparison of Sense Resistors**

	Motherboard Trace Resistor	Discrete Iron Alloy resistor (IRC)	Discrete Metal Strip surface mount resistor (Dale)	Discrete MnCu Alloy wire resistor	Discrete CuNi Alloy wire resistor (Copel)
Tolerance Factor (TF)	$\pm 29\%$	$\pm 5\%$ ( $\pm 1\%$ available)	$\pm 1\%$	$\pm 10\%$	$\pm 10\%$
Size (L x W x H)	2" x 0.2" x 0.001" (1 oz Cu trace)	0.45" x 0.065" x 0.2"	0.25" x 0.125" x 0.025"	0.2" x 0.04" x 0.16"	0.2" x 0.04" x 0.1"
Power capability	>50A/in	1 watt (3 and 5 watts available)	1 watt (3 and 5 watts available)	1 watt	1 watt
Temperature Coefficient	+4,000 ppm	+30 ppm	$\pm 75$ ppm	$\pm 30$ ppm	$\pm 20$ ppm
Cost@10,000 piece quantity	Low; included in motherboard	\$0.31	\$0.47	\$0.09	\$0.09

Based on the Tolerance in Table 3:

- For an embedded PC trace resistor:

$$R_{SENSE} = \frac{V_{th,min}}{1.5 + I_{LOAD,MAX}} \times (1 - TF)$$

$$= \frac{80mV}{1.5A + 10A} \times (1 - 29\%) = 4.9m\Omega$$

- For a discrete resistor:

$$R_{SENSE} = \frac{V_{th,min}}{1.5 + I_{LOAD,MAX}} \times (1 - TF)$$

$$= \frac{80mV}{1.5A + 10A} \times (1 - 5\%) = 6.6m\Omega$$

Table 4 lists recommended values for sense resistors for various load currents using an embedded PC trace resistor or a discrete resistor.

**Table 4. RSENSE for Various Load Currents, Switching Regulator**

I <sub>LOAD, MAX</sub> (A)	R <sub>SENSE</sub> PC Trace Resistor (mΩ)	R <sub>SENSE</sub> Discrete Resistor (mΩ)
5	8.7	11.7
6	7.6	10.1
7	6.7	8.9
8	6.0	8.0
9	5.4	7.2
10	4.9	6.6

Since the value of the sense resistor is often less than 10mΩ, care should be taken in the layout of the PCB. Trace resistance can contribute significant errors. The traces to the IFBH and IFBL pins of the RC5036 should be Kelvin connected to the pads of the current-sense resistor. To minimize the influence of noise, the two traces should be run next to each other.

### For the Linear Regulator

The analysis for short circuit protection of the linear regulator is much simpler than that of the switching regulator. The formula for the inception point of short-circuit protection for the linear regulator is:

$$R_{SENSE} = \frac{V_{th,min}}{I_{LOAD,MAX}} \times (1 - TF)$$

$$V_{th} = 45mV \pm 8mV \text{ and } I_{LOAD,MAX} = 5A,$$

$$R_{SENSE} = \frac{37mV}{5A} \times (1 - 29\%) = 5.3m\Omega \text{ for using an embedded PC trace resistor}$$

$$R_{SENSE} = \frac{37mV}{5A} \times (1 - 5\%) = 7.0m\Omega \text{ for using a discrete resistor}$$

Table 5 lists recommended values for sense resistors for various load currents using an embedded PC trace resistor or a discrete resistor.

**Table 5. RSENSE for Various Load Currents, Linear Regulator**

I <sub>LOAD, MAX</sub> (A)	R <sub>SENSE</sub> PC Trace Resistor (mΩ)	R <sub>SENSE</sub> Discrete Resistor (mΩ)
2	13.1	17.6
3	8.8	11.7
4	6.6	8.8
5	5.3	7.0
6	4.4	5.9

### Thermal Design Considerations

Good thermal management is critical in the design of high current regulators. System reliability will be degraded if the component temperatures become excessive. The following guide should serve as a reference for proper thermal management.

#### MOSFET Temperature

The maximum power dissipation of the MOSFET can be calculated by using the following formula:

$$P_D = \frac{T_{J(MAX)} - T_A}{\Theta_{JA}}$$

For IR 3103,  $\Theta_{JA}$  is 42°C/W. For reliability the junction temperature of the MOSFET should not exceed 120°C. Assuming that the ambient temperature is 40°C, then the maximum power dissipation is calculated as:

$$P_D = \frac{120 - 40}{42} = 1.905W$$

The power that the MOSFET dissipates at the rated 6A load is calculated as follows:

$$P_{MOSFET} = I_{LOAD}^2 \times R_{DS(ON)} \times (\text{Duty Cycle}) + \frac{V_{IN} \times I_{LOAD}}{6} \times (t_r + t_f) \times f$$

$$\text{Duty Cycle} = \frac{V_{OUT} + V_D}{V_{IN} + V_D - (I_{LOAD} \times R_{DS(ON)})}$$

where  $V_D$  is the forward voltage of the Schottky diode used.

Using the above formula, for  $V_{OUT} = 2.8V$ ,  $I_{LOAD} = 6A$

$$\text{Duty Cycle} = \frac{2.8 + 0.57}{2.8 + 0.57 - (6 \times 0.019)} = 61.8\%$$

$$P_{MOSFET} = 6A^2 \times 0.019\Omega \times 61.8\% + \frac{5V \times 6A}{6} \times (210ns + 54ns) \times 300KHz$$

$$P_{MOSFET} = 0.82W$$

Since the power at 6A is within the thermal guideline, a heat sink is not required other than the PCB.

**Schottky Diode**

In Figure 14, MOSFET M1 and flyback diode DS1 are used as complementary switches in order to maintain a constant current through the output inductor L1. As a result, DS1 will have to carry the full current of the output load when the power MOSFET is turned off. The power in the diode is a direct function of the forward voltage at the rated load current during the off time of the FET. The following equation can be used to estimate the diode power:

$$P_{DIODE} = I_D \times V_D \times (1 - DutyCycle)$$

where  $I_D$  is the forward current of the diode,  $V_D$  is the forward voltage of the diode, and DutyCycle is defined the same as above.

For the Motorola MBR2030CTL Power Rectifier used in Figure 14,

$$P_{DIODE} = 10A \times 0.57 \times (1 - 64.8\%) = 2.0W$$

It is recommended that the diode T0-220 package be placed down on the motherboard to utilize the power plane as a heatsink and achieve a thermal resistance of 40°C/W.

**Board Design Considerations**

**RC5036 Placement**

The RC5036 should be placed as close to the core voltage supply pins of the P55C as possible. Preferably the PC layer directly underneath the RC5036 should be the ground layer. This serves as extra isolation from noisy power planes.

**MOSFET Placement**

Placement of the power MOSFET is critical in the design of the switch-mode regulator. The FET should be placed in such a way as to minimize the length of the gate drive path from the RC5036 SDRV pin. This trace should be kept under 0.5" for optimal performance. Excessive lead length on this trace causes high frequency noise resulting from the parasitic inductance and capacitance of the trace. Since this voltage can transition nearly 12V in around 100nsec, the resultant ringing and noise will be very difficult to suppress. This trace should be routed on one layer only and kept well away from the "quiet" analog pins of the device: VREF, CEXT, FBSW, IFBH, IFBL, and VFBL. Refer to Figure 15. A 10Ω resistor in series with the gate of the MOSFET can decrease this layout critically.

**Inductor and Schottky Diode Placement**

The inductor and fly-back Schottky diode must be placed close to the source of the power MOSFET. The node connecting the inductor and the diode swing between the drain voltage of the FET and the forward voltage of the Schottky diode. It is recommended that this node be converted to a plane if possible. This node is part of the high current path in the design, and is best treated as a plane to minimize the parasitic resistance and inductance on that node.

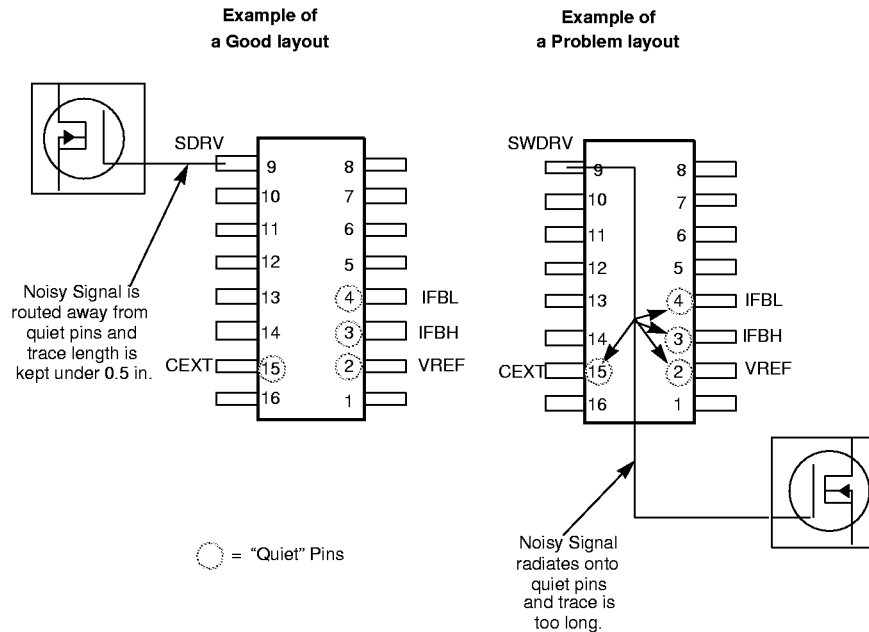

Figure 15. Examples of good and poor layouts

Most PC board manufacturers utilize 1/2oz copper on the top and bottom signal layers of the PCB; thus, it is not recommended to use these layers to route the high current portions of the regulator design. Since it is more common to use 1 oz. copper on the PCB inner layers, it is recommended to use those layers to route the high current paths in the design.

**Capacitor Placement**

One of the keys to a successful switch-mode power supply design is correct placement of the low ESR capacitors. Decoupling capacitors serve two purposes; first there must be enough bulk capacitance to support the expected transient current of the CPU, and second, there must be a variety of values and capacitor types to provide noise suppression over a wide range of frequencies. The low ESR capacitors on the input side (5V) of the FET must be located close to the drain of the power FET. Minimizing parasitic inductance and resistance is critical in suppressing the ringing and noise spikes on the power supply. The output low ESR capacitors need to be placed close to the output sense resistor to provide good decoupling at the voltage sense point. One of the characteristics of good low ESR capacitors is that the impedance gradually increases as the frequency increases. Thus for high frequency noise suppression, good quality low inductance ceramic capacitors need to be placed in parallel with the low ESR bulk capacitors. These can usually be 0.1µF 1206 surface mount capacitors.

**Power and Ground Connections**

The connection of VCCA to the 5V power supply plane should be short and bypassed with a 0.1µF directly at the VCCA pin of the RC5036. The ideal connection would be a via down to the 5V power plane. A similar arrangement should be made for the VCCL pin that connects to +12V, though this one is somewhat less critical since it powers only the linear op-amp. Each ground should have a separate via connection to the ground plane below.

**MOSFET Gate Bias**

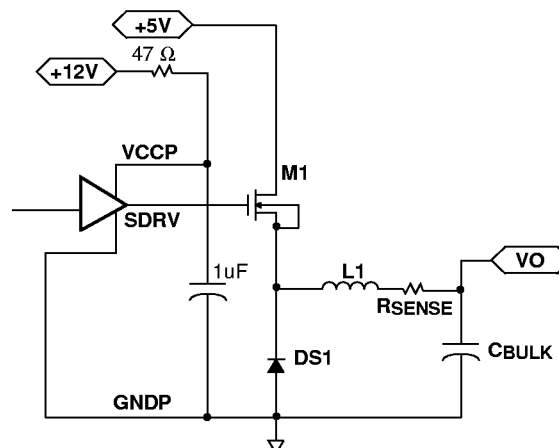

**Figure 16. 12V Gate Bias Configuration**

A 12V power supply is used to bias the VCCP. A 47Ω resistor is used to limit the transient current into VCCP. A 1µF capacitor filter is used to filter the VCCP supply and source the transient current required to charge the MOSFET gate capacitance. This method provides sufficiently high gate bias voltage to the MOSFET (VGS), and therefore reduces RDS(ON) of the MOSFET and its power loss.

Figure 16 provides about 5V of gate bias which works well when using typical logic-level MOSFETs, as shown in Figure 17.

**Layout Gerber File and Silk Screen**

A reference design for motherboard implementation of the RC5036 along with the Layout Gerber File and the Silk Screen is available. Please call Raytheon Electronics Semiconductor Division’s Marketing Department at 650-966-7819 to obtain this information.

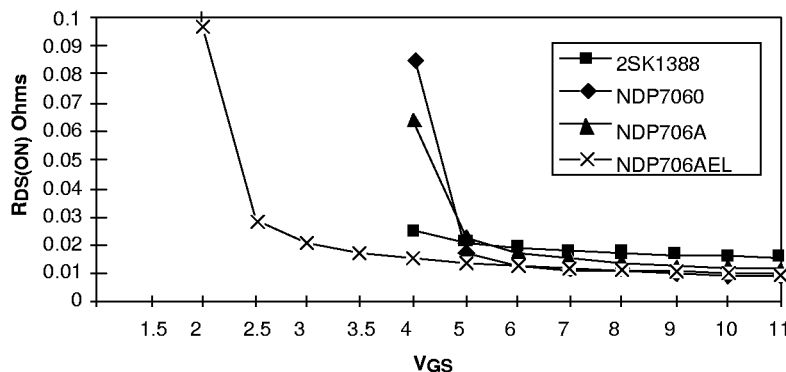

**Figure 17. RDS(ON) vs. VGS for Selected Logic-Level MOSFETs**

**RC5036 Evaluation Board**

Raytheon Electronics Semiconductor Division provides an evaluation board for verifying the system level performance of the RC5036. The evaluation board provides a guide as to what can be expected in performance with the supplied external components and PCB layout. Please call your local Sales Office or Raytheon Electronics Semiconductor Division at 650-968-9211 for an evaluation board.



**Notes:**

**Notes:**

# Mechanical Dimensions

## 16-Lead SOIC Package

Symbol	Inches		Millimeters		Notes
	Min.	Max.	Min.	Max.	
A	.053	.069	1.35	1.75	
A1	.004	.010	0.10	0.25	
B	.013	.020	0.33	0.51	
C	.008	.010	0.19	0.25	5
D	.386	.394	9.80	10.00	2
E	.150	.158	3.81	4.00	2
e	.050 BSC		1.27 BSC		
H	.228	.244	5.80	6.20	
h	.010	.020	0.25	0.50	
L	.016	.050	0.40	1.27	3
N	16		16		6
$\alpha$	0°	8°	0°	8°	
ccc	—	.004	—	0.10	

**Notes:**

1. Dimensioning and tolerancing per ANSI Y14.5M-1982.
2. "D" and "E" do not include mold flash. Mold flash or protrusions shall not exceed .010 inch (0.25mm).
3. "L" is the length of terminal for soldering to a substrate.
4. Terminal numbers are shown for reference only.
5. "C" dimension does not include solder finish thickness.
6. Symbol "N" is the maximum number of terminals.

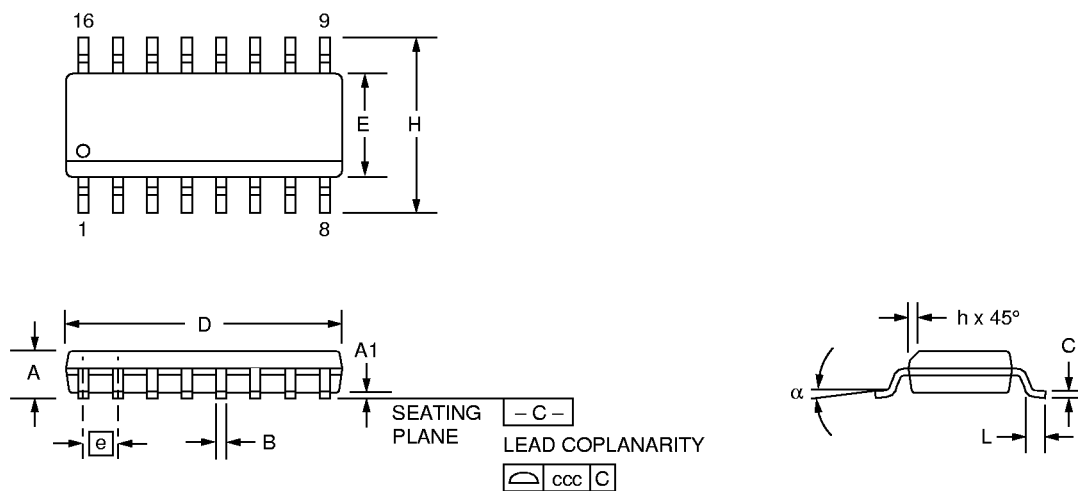

## Ordering Information

Product Number	Package
RC5036M	16 pin SOIC

The information contained in this data sheet has been carefully compiled; however, it shall not by implication or otherwise become part of the terms and conditions of any subsequent sale. Raytheon's liability shall be determined solely by its standard terms and conditions of sale. No representation as to application or use or that the circuits are either licensed or free from patent infringement is intended or implied. Raytheon reserves the right to change the circuitry and any other data at any time without notice and assumes no liability for errors.

### LIFE SUPPORT POLICY:

Raytheon's products are not designed for use in life support applications, wherein a failure or malfunction of the component can reasonably be expected to result in personal injury. The user of Raytheon components in life support applications assumes all risk of such use and indemnifies Raytheon Company against all damages.

Raytheon Electronics  
Semiconductor Division  
350 Ellis Street  
Mountain View, CA 94043  
650.968.9211  
FAX 650.966.7742