

DM74ALS240A/DM74ALS241A/74ALS240A-1 Octal 3-STATE Bus Driver

General Description

These octal 3-STATE bus drivers are designed to provide the designer with flexibility in implementing a bus interface with memory, microprocessor, or communication systems. The output 3-STATE gating control is organized into two separate groups of four buffers. The 'ALS240A control inputs symmetrically enable the respective outputs when set logic low, while the 'ALS241A has complementary enable gating. The 3-STATE circuitry contains a feature that maintains the buffer outputs in 3-STATE (high impedance state) during power supply ramp-up or ramp-down. This eliminates bus glitching problems that arise during power-up and power-down.

The 'ALS240-1 version features the same performance as the standard version with the addition of increased current drive capability to meet the current requirements of various bus architectures. For all ALS-1 products, the recommended maximum I_{OL} is increased to 48 mA.

Features

- Maximum I_{OL} increased to 48 mA for 'ALS240A-1 product
- Advanced low power oxide-isolated ion-implanted Schottky TTL process
- Functional and pin compatible with the DM74LS counterpart
- Improved switching performance with less power dissipation compared with the DM74LS counterpart
- Switching response specified into 500Ω and 50 pF load
- Switching response specifications guaranteed over full temperature and V_{CC} supply range
- PNP input design reduces input loading
- Low level drive current: 74ALS = 24 mA

Connection Diagrams

Dual-In-Line Package

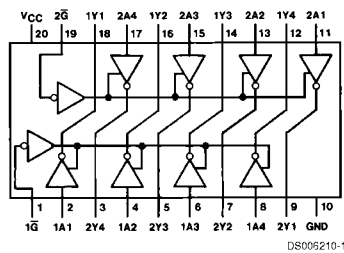

DS005210-1

Top View

Order Number DM74ALS240AWM, DM74ALS240AN,
DM74ALS240ASJ,
74ALS240A-1N or 74ALS240A-1WM
See Package Number M20B, M20D or N20A

Dual-In-Line Package

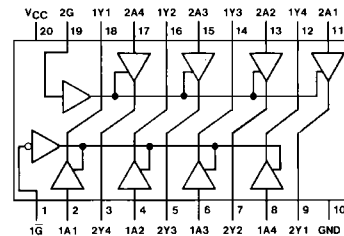

DS005210-2

Top View

Order Number DM74ALS241AWM
or DM74ALS241AN
See Package Number M20B or N20A

Function Tables

'ALS240A, 'ALS240A-1

Input		Output
\overline{G}	A	Y
L	L	H
L	H	L
H	X	Z

'ALS241A

Input		Output
2G	2A	Y
H	L	L
H	H	H
L	X	Z

'ALS241A

Input		Output
1G	1A	Y
L	L	L
L	H	H
H	X	Z

H = High Level Logic State
L = Low Level Logic State
X = Don't Care (Either Low or High Level Logic State)
Z = High Impedance (Off) State

Absolute Maximum Ratings (Note 1)

Supply Voltage, V_{CC}	7V	DM74ALS	0°C to +70°C
Input Voltage	7V	Storage Temperature Range	-65°C to +150°C
Voltage Applied to Disabled Output	5.5V	Typical θ_{JA}	
Operating Free Air Temperature Range		N Package	60.5°C/W
		M Package	79.8°C/W

Recommended Operating Conditions

Symbol	Parameter	DM74ALS240A, 240A-1, 241A			Units
		Min	Typ	Max	
V_{CC}	Supply Voltage	4.5	5	5.5	V
V_{IH}	High Level Input Voltage	2			V
V_{IL}	Low Level Input Voltage			0.8	V
I_{OH}	High Level Output Current			-15	mA
I_{OL}	Low Level	'ALS240A, 'ALS241A			mA
	Output Current	'ALS240A-1			
T_A	Operating Free Air Temperature	0		70	°C

Note 1: The "Absolute Maximum Ratings" are those values beyond which the safety of the device cannot be guaranteed. The device should not be operated at these limits. The parametric values defined in the "Electrical Characteristics" table are not guaranteed at the absolute maximum ratings. The "Recommended Operating Conditions" table will define the conditions for actual device operation.

Electrical Characteristics

over recommended operating free-air temperature range (unless otherwise specified)

Symbol	Parameter	Conditions	DM74ALS240A, 240A-1, 241A			Units
			Min	Typ	Max	
V_{IK}	Input Clamp Voltage	$V_{CC} = 4.5V, I_I = -18 \text{ mA}$			-1.5	V
V_{OH}	High Level Output Voltage	$V_{CC} = 4.5V \text{ to } 5.5V, I_{OH} = -0.4 \text{ mA}$	$V_{CC} - 2$			V
		$V_{CC} = 4.5V, I_{OH} = -3 \text{ mA}$	2.4			V
		$I_{OH} = \text{Max}$	2			V
V_{OL}	Low Level Output Voltage	$V_{CC} = 4.5V, I_{OL} = \text{Max}$		0.35	0.5	V
I_I	Input Current at Max Input Voltage	$V_{CC} = 5.5V, V_I = 7V$			0.1	mA
I_{IH}	High Level Input Current	$V_{CC} = 5.5V, V_I = 2.7V$			20	μA
I_{IL}	Low Level Input Current	$V_{CC} = 5.5V, V_{IL} = 0.4V$			-0.1	mA
I_O	Output Drive Current	$V_{CC} = 5.5V, V_O = 2.25V$	-30		-112	mA
I_{OZH}	High Level 3-STATE Output Current	$V_{CC} = 5.5V, V_O = 2.7V$			20	μA
I_{OZL}	Low Level 3-STATE Output Current	$V_{CC} = 5.5V, V_O = 0.4V$			-20	μA
I_{CC}	Supply Current	$V_{CC} = 5.5V, \text{ALS240A, ALS240A-1}$ Outputs High		4	10	mA
		Outputs Low		13	23	mA
		Outputs 3-STATE		14	25	mA
		$V_{CC} = 5.5V, \text{ALS241A}$ Outputs High		9	15	mA
		Outputs Low		15	26	mA
		Outputs 3-STATE		17	30	mA

'ALS240A and 240A-1 Switching Characteristics

over recommended operating free air temperature range (Note 2)

Symbol	Parameter	Conditions	From (Input)	To (Output)	DM74ALS240A, 74ALS240A-1		Units
					Min	Max	
t _{PLH}	Propagation Delay Time Low to High Level Output	V _{CC} = 4.5V to 5.5V, C _L = 50 pF, R1 = 500Ω, R2 = 500Ω, T _A = Min to Max	A	Y	2	9	ns
t _{PHL}	Propagation Delay Time High to Low Level Output				2	9	ns
t _{PZH}	Output Enable Time to High Level Output		G̅	Y	3	13	ns
t _{PZL}	Output Enable Time to Low Level Output				3	18	ns
t _{PHZ}	Output Disable Time from High Level Output		G̅	Y	2	10	ns
t _{PLZ}	Output Disable Time from Low Level Output				3	12	ns

'ALS241A Switching Characteristics

over recommended operating free air temperature range (Note 2)

Symbol	Parameter	Conditions	From (Input)	To (Output)	DM74ALS241A		Units
					Min	Max	
t _{PLH}	Propagation Delay Time Low to High Level Output	V _{CC} = 4.5V to 5.5V, C _L = 50 pF, R1 = 500Ω, R2 = 500Ω, T _A = Min to Max	A	Y	3	11	ns
t _{PHL}	Propagation Delay Time High to Low Level Output				3	10	ns
t _{PZH}	Output Enable Time to High Level Output		1G̅	Y	3	21	ns
t _{PZL}	Output Enable Time to High Level Output				3	21	ns
t _{PHZ}	Output Disable Time to High Level Output		1G̅	Y	2	10	ns
t _{PLZ}	Output Disable Time to Low Level Output				3	15	ns
t _{PZH}	Output Enable Time to High Level Output		2G	Y	7	21	ns
t _{PZL}	Output Enable Time to Low Level Output				7	21	ns
t _{PHZ}	Output Disable Time from High Level Output		2G	Y	2	10	ns
t _{PLZ}	Output Disable Time from Low Level Output				3	15	ns

Note 2: See Section 5 for test waveforms and output load.

Logic Diagrams

ALS240A, ALS240A-1

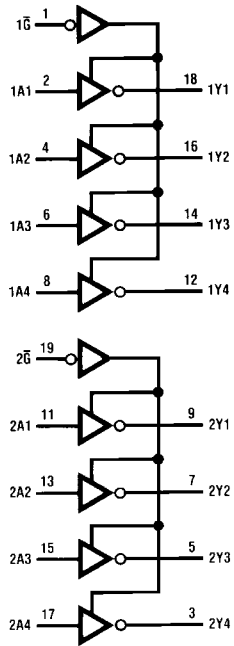

DS006210-3

ALS241A

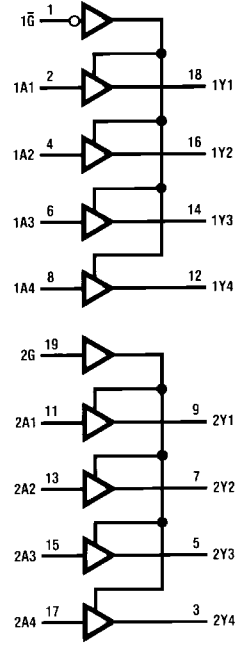

DS006210-4

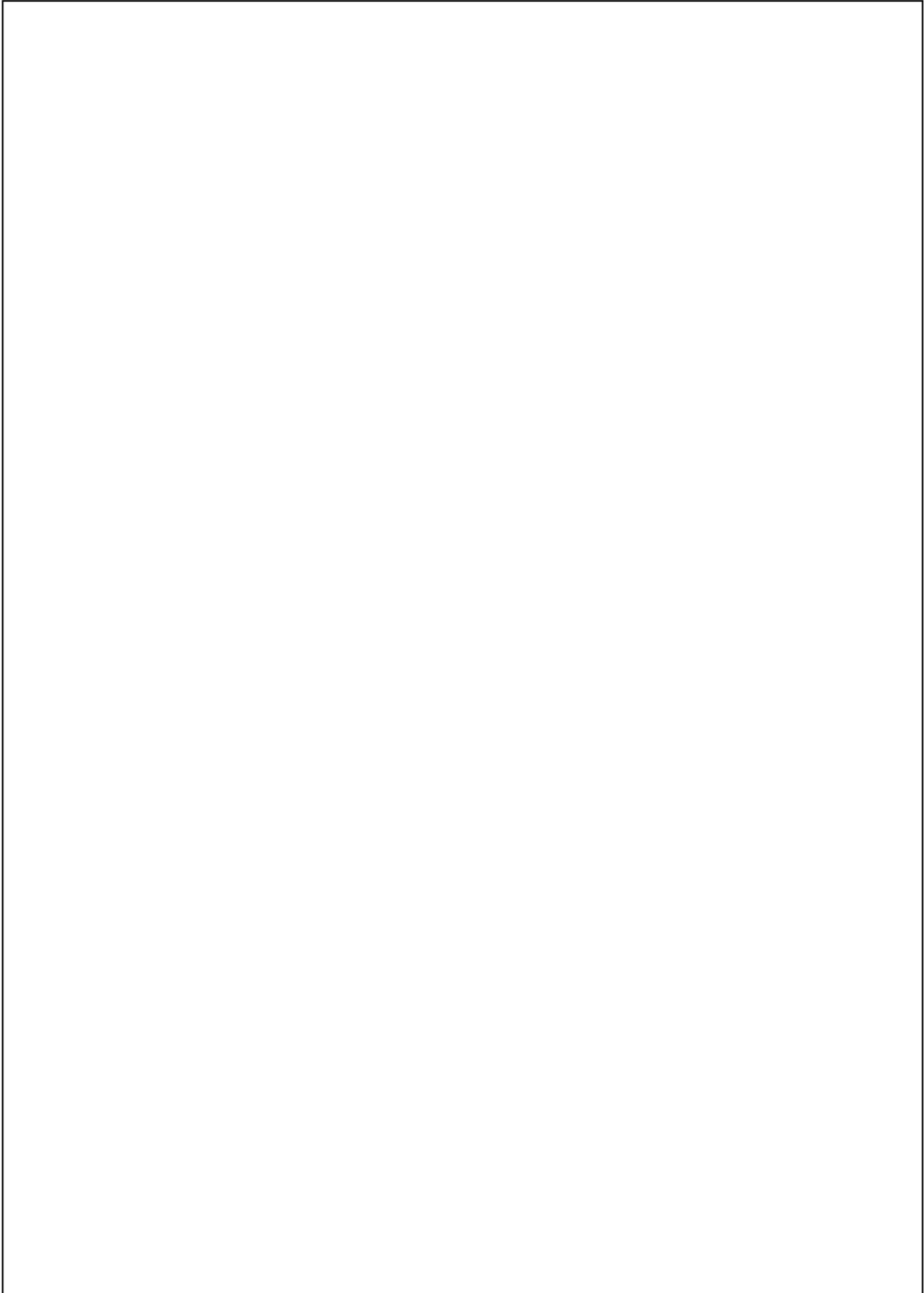

Physical Dimensions inches (millimeters) unless otherwise noted

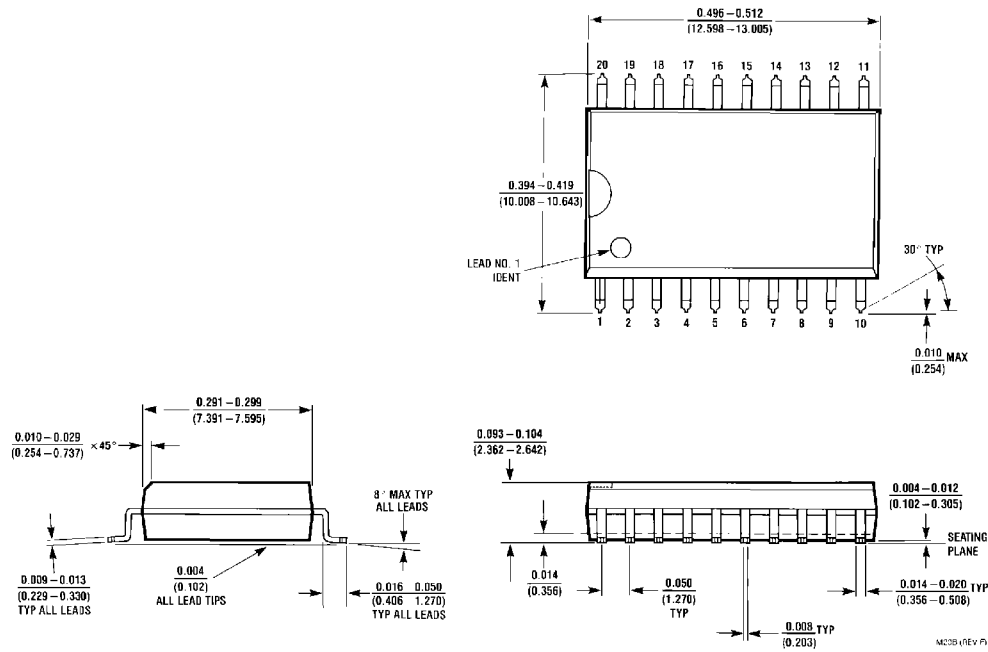

S.O. Package (M)
Order Number DM74ALS240AWM, 74ALS240A-1WM or DM74ALS241AWM
Package Number M20B

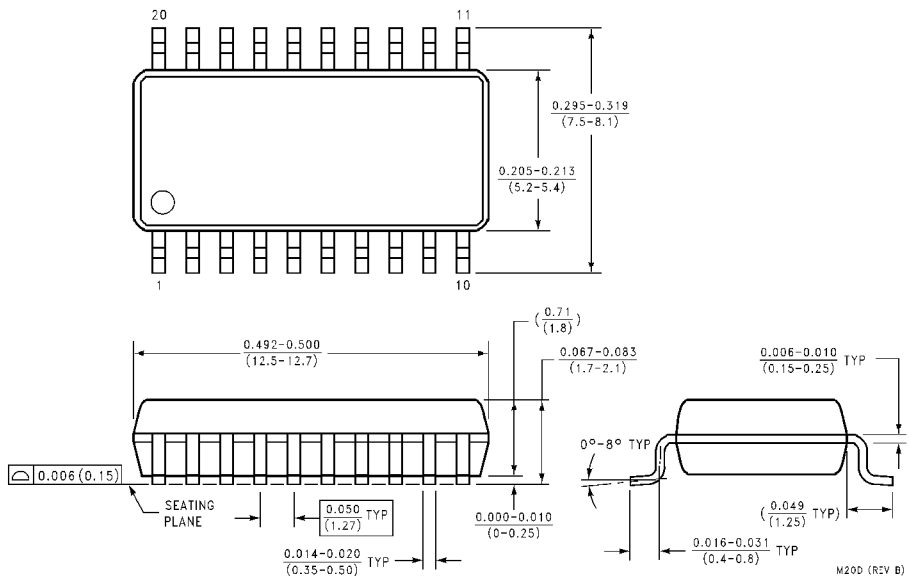

S.O. Package (M)
Order Number DM74ALS240ASJ
Package Number M20D

Physical Dimensions inches (millimeters) unless otherwise noted (Continued)

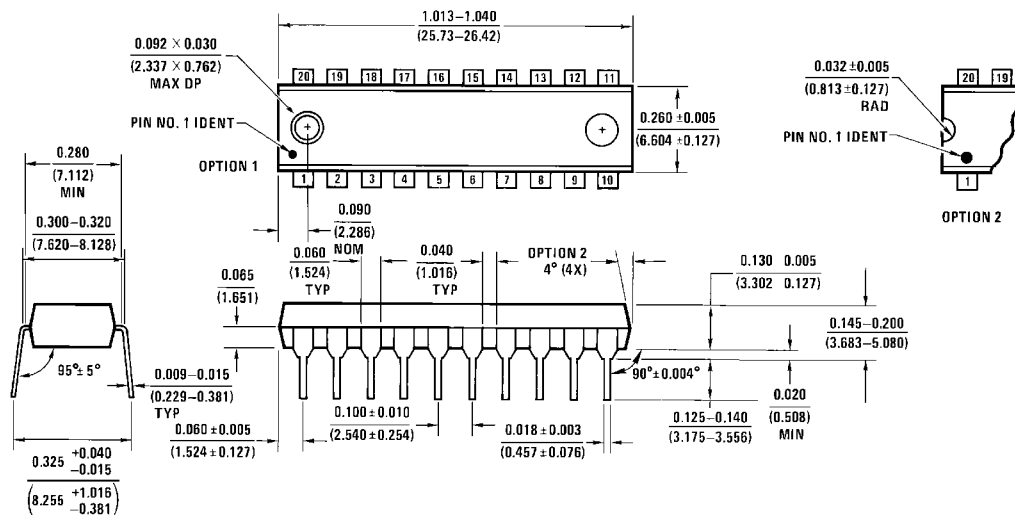

N20A (REV G)

Molded Dual-In-Line Package (N)
Order Number DM74ALS240AN, DM74ALS241AN or 74ALS240A-1N
Package Number N20A

LIFE SUPPORT POLICY

FAIRCHILD'S PRODUCTS ARE NOT AUTHORIZED FOR USE AS CRITICAL COMPONENTS IN LIFE SUPPORT DEVICES OR SYSTEMS WITHOUT THE EXPRESS WRITTEN APPROVAL OF THE PRESIDENT OF FAIRCHILD SEMICONDUCTOR CORPORATION. As used herein:

1. Life support devices or systems are devices or systems which, (a) are intended for surgical implant into the body, or (b) support or sustain life, and (c) whose failure to perform when properly used in accordance with instructions for use provided in the labeling, can be reasonably expected to result in a significant injury to the user.
2. A critical component in any component of a life support device or system whose failure to perform can be reasonably expected to cause the failure of the life support device or system, or to affect its safety or effectiveness.

Fairchild Semiconductor Corporation
 Americas
 Customer Response Center
 Tel: 1-888-522-5372

Fairchild Semiconductor Europe
 Fax: +49 (0) 1 80-530 85 86
 Email: europe.support@nsc.com
 Deutsch Tel: +49 (0) 8 141-35-0
 English Tel: +44 (0) 1 793-85-68-56
 Italy Tel: +39 (0) 2 57 5631

Fairchild Semiconductor Hong Kong Ltd.
 13th Floor, Straight Block,
 Ocean Centre, 5 Canton Rd.
 Tsimshatsui, Kowloon
 Hong Kong
 Tel: +852 2737-7200
 Fax: +852 2314-0061

National Semiconductor Japan Ltd.
 Tel: 81-3-5620-6175
 Fax: 81-3-5620-6179

www.fairchildsemi.com