

HD100171

Triple 4-input Multiplexers with Enable

The HD100171 contains Triple 4-input multiplexers which share a common decoder (inputs S_0 and S_1). Output buffer gates provide true and

complement outputs. A high on the Enable input (\bar{E}) forces all true outputs low (see truth table).

PIN ARRANGEMENT

HD100171

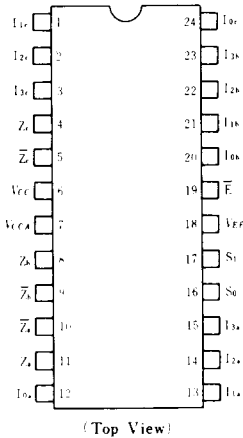

HD100171F

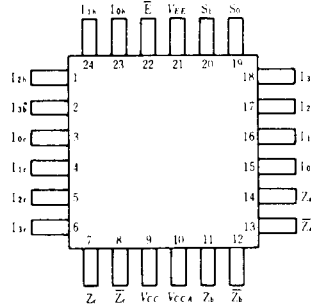

LOGIC DIAGRAM

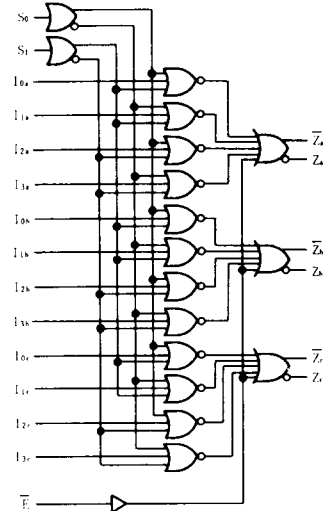

TRUTH TABLE

\bar{E}	S_0	S_1	Z_s
L	L	L	I_{0s}
L	H	L	I_{1s}
L	L	H	I_{2s}
L	H	H	I_{3s}
H	x	x	L

DC CHARACTERISTICS ($V_{EE} = -4.2$ to $-4.8V$, $V_{CC} = V_{CCA} = GND$, $T_a = 0$ to $+85^\circ C$)

Item	Symbol	Test Condition	min	typ	max	Unit
Supply Current	I_{EE}	All input open	56	81	114	mA
Input Current	I_{IH}	S_0, S_1, \bar{E} input	—	—	300	μA
		Data input	—	—	340	μA

Note) As for other items, refer to the "Common DC Characteristics".

■ AC CHARACTERISTICS ($V_{EE} = -2.2$ to $-2.8V$, $V_{CC} = V_{CCA} = 2.0V$)

● HD100171

Item	Symbol	Test Condition	0°C		25°C			85°C		Unit	
			min	max	min	typ	max	min	max		
Propagation Delay Time	t_{PLH}, t_{PHL}	See test circuit and waveform	$I_{OS} - I_{IS}$ input to output	0.45	1.30	0.55	0.95	1.40	0.60	1.45	ns
			$S_0 - S_1$ input to output	0.90	2.10	1.00	1.30	2.20	1.00	2.20	
			\bar{E} input to output	0.80	1.95	0.90	1.50	2.05	0.90	2.05	
Transition Time	t_{TLH}, t_{THL}		0.40	1.40	0.40	0.80	1.40	0.40	1.40	ns	

● HD100171F

Item	Symbol	Test Condition	0°C		25°C			85°C		Unit	
			min	max	min	typ	max	min	max		
Propagation Delay Time	t_{PLH}, t_{PHL}	See test circuit and waveform	$I_{OS} - I_{IS}$ input to output	0.45	1.25	0.55	0.90	1.30	0.55	1.40	ns
			$S_0 - S_1$ input to output	1.00	2.20	1.00	1.40	2.30	1.00	2.30	
			\bar{E} input to output	0.80	2.00	0.90	1.50	2.10	0.90	2.10	
Transition Time	t_{TLH}, t_{THL}		0.45	1.35	0.45	0.90	1.35	0.45	1.35	ns	

Note) The circuits in a test socket or mounted on a printed circuit board and transverse air flow greater than 2.5 m/s (500 linear fpm) is maintained.