

# PCF8582A

## Static CMOS EEPROM

### (256 × 8-bit)

Preliminary Specification

### Linear Products

### DESCRIPTION

The PCF8582A is 2K-bit 5V electrically erasable programmable read only memory (EEPROM) organized as 256 by 8 bits. It is designed in a floating-gate CMOS technology.

As data bytes are received and transmitted via the serial I<sup>2</sup>C bus, an 8-pin DIP package is sufficient. Up to eight PCF8582A devices may be connected to the I<sup>2</sup>C bus.

Chip select is accomplished by three address inputs.

### FEATURES

- Non-volatile storage of 2K-bit organized as 256 × 8
- Only one power supply required (5V)
- On-chip voltage multiplier for erase/write
- Serial input/output bus (I<sup>2</sup>C)
- Automatic word address incrementing
- Low power consumption
- One point erase/write timer
- Power-on reset
- 10,000 erase/write cycles per byte
- 10 years non-volatile data retention
- Infinite number of read cycles
- Pin-and address-compatible to PCF8570 and PCF8571

### APPLICATIONS

- Telephony
- Radio and television
- General purpose

### ORDERING INFORMATION

DESCRIPTION	TEMPERATURE RANGE	ORDER CODE
8-Pin Plastic DIP (SOT-97A)	-40°C to +85°C	PCF8582APN
16-Pin Plastic SO (SO16L; SOT-162A)	-40°C to +85°C	PCF8582ATD

### ABSOLUTE MAXIMUM RATINGS

SYMBOL	PARAMETER	RATING	UNIT
V <sub>DD</sub>	Supply voltage	-0.3 to 7	V
V <sub>IN</sub>	Input voltage, at Pin 4, (input impedance 500Ω)	V <sub>SS</sub> - 0.8 to V <sub>DD</sub> + 0.8	V
T <sub>A</sub>	Operating temperature range	-40 to +85	°C
T <sub>STG</sub>	Storage temperature range	-65 to +150	°C
I <sub>I</sub>	Current into any input pin	1	mA
I <sub>O</sub>	Output current	10	mA

### PIN CONFIGURATION

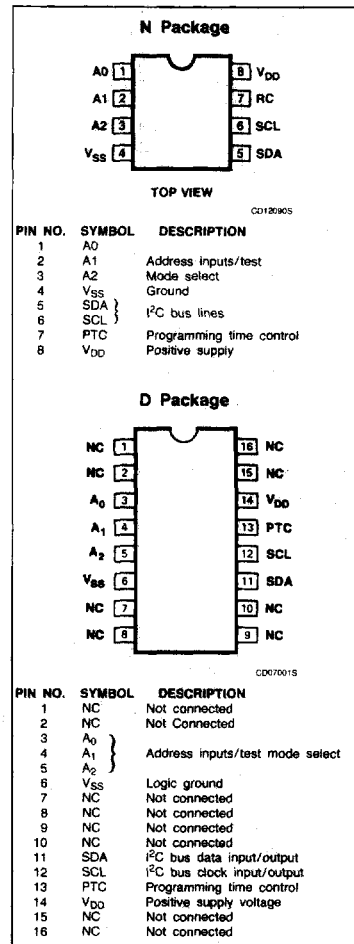

Static CMOS EEPROM

PCF8582A

BLOCK DIAGRAM

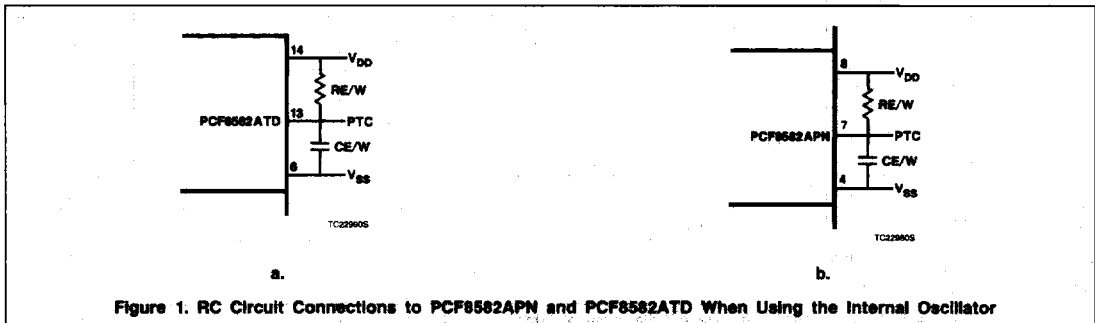
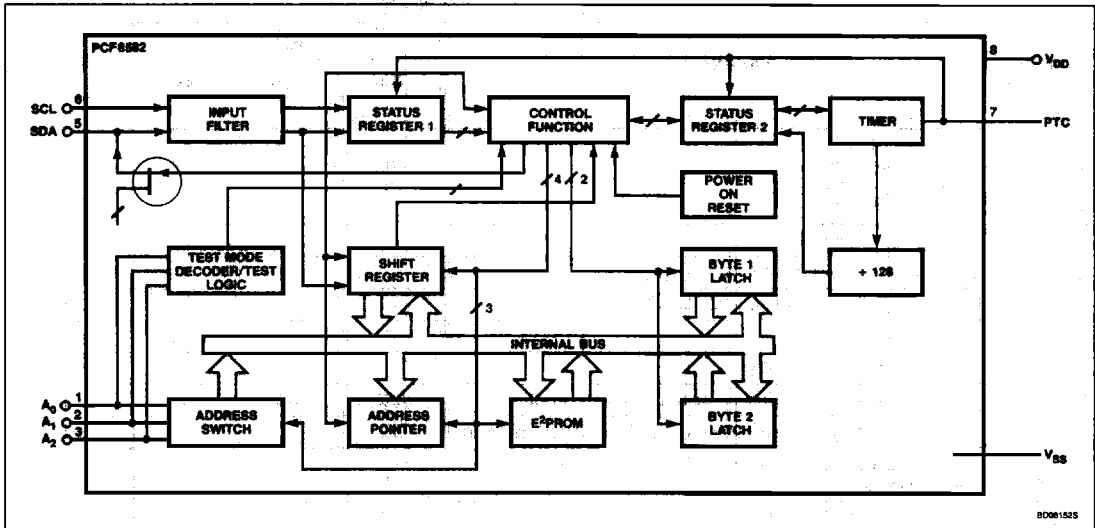

Figure 1. RC Circuit Connections to PCF8582APN and PCF8582ATD When Using the Internal Oscillator

DC AND AC ELECTRICAL CHARACTERISTICS VDD = 5V; VSS = 0V; TA = -40°C to +85°C, unless otherwise specified.

SYMBOL	PARAMETER	LIMITS			UNIT
		Min	Typ	Max	
VDD	Operating supply voltage	4.5	5	5.5	V
IDDR	Operating supply current, READ (VDD MAX, fSCLC = 100kHz)			0.4	mA
IDDW	Operating supply current, WRITE/ERASE			2.0	mA
IDDO	Standby supply current (VDD MAX)			10	μA
<b>Input PTC</b>					
VIH-P	Input voltage High	VDD - 0.3			V
VIL-P	Input voltage Low			VSS + 0.3	V

## Static CMOS EEPROM

PCF8582A

DC AND AC ELECTRICAL CHARACTERISTICS (Continued)  $V_{DD} = 5V$ ;  $V_{SS} = 0V$ ;  $T_A = -40^{\circ}C$  to  $+85^{\circ}C$ , unless otherwise specified.

SYMBOL	PARAMETER	LIMITS			UNIT
		Min	Typ	Max	
<b>Input SCL</b>					
$V_{IL}$ $V_{IH}$ $V$	Input/output SDA: Input voltage LOW Input voltage HIGH Output voltage LOW	-0.3 3		1.5 $V_{DD} + 0.8$	V V
$V_{OL}$	( $I_{OL} = 3mA$ , $V_{DD} = 4.5V$ )			0.4	V
$I_{OH}$	Output leakage current HIGH ( $V_{OH} = V_{DD}$ )			1	$\mu A$
$\pm I_{IN}$	Input leakage current (A0, A1, A2, SCL) <sup>1</sup>			1	$\mu A$
$f_{SCL}$	Clock frequency	0		100	kHz
$C_I$	Input capacitance (SCL, SDA)			7	pF
$t_i$	Noise suppression time constant at SCL and SDA input	0.25	0.5	1	$\mu s$
$t_{BUF}$	Time the bus must be free before a new transmission can start	4.7			$\mu s$
$t_{HD}$ , $t_{STA}$	Hold time start condition. After this period the first clock pulse is generated	4			$\mu s$
$t_{LOW}$	The LOW period of the clock	4.7			$\mu s$
$t_{HIGH}$	The HIGH period of the clock	4			$\mu s$
$t_{SU}$ , $t_{STA}$	Setup time for start condition (only relevant for a repeated start condition)	4.7			$\mu s$
$t_{HD}$ , $t_{DAT}$ $t_{HD}$ , $t_{DAT}$	Hold time DATA for: CBUS compatible masters I <sup>2</sup> C devices <sup>2</sup>	5 0			$\mu s$ $\mu s$
$t_{SU}$ , $t_{DAT}$	Setup time DATA	250			ns
$t_R$	Rise time for both SDA and SCL lines			1	$\mu s$
$t_F$	Fall time for both SDA and SCL lines			300	ns
$t_{SU}$ , $t_{STO}$	Setup time for stop condition	4.7			$\mu s$
<b>Erase/write timer constant</b>					
$C_{E/W}$	Erase/write timing capacitor for erase/write cycle of 30ns <sup>3</sup>		3.3		nF
$R_{E/W}$	Erase/write cycle timing resistor <sup>4</sup>		56.0		k $\Omega$
<b>Programming frequency using external clock</b>					
$f_P$	Frequency	2.57		12.85	kHz
$t_{LOW}$	Period Low	10.0			$\mu s$
$t_{HIGH}$	Period High	10.0			$\mu s$
$t_R$	Rise time			300	ns
$t_F$	Fall time			300	ns
$t_D$	Delay time	0			ns
$t_S$	Data retention time ( $T_A = 55^{\circ}C$ )	10			years

## NOTES:

- Selection of the chip address is done by connecting the A0, A1, and A2 inputs either to  $V_{SS}$  or  $V_{DD}$ .
- A transmitter must internally provide a hold time to bridge the undefined region (maximum 300ns) of the falling edge of SCL.
- Maximum tolerance  $\pm 10\%$  using internal oscillator.
- Maximum tolerance  $\pm 5\%$  using internal oscillator.

## Static CMOS EEPROM

PCF8582A

### FUNCTIONAL DESCRIPTION

#### Characteristics of the I<sup>2</sup>C Bus

The I<sup>2</sup>C bus is intended for communication between different ICs. The serial bus consists of two bidirectional lines, one for data signals (SDA), and one for clock signals (SCL). Both the SDA and the SCL lines must be connected to a positive supply voltage via a pull-up resistor.

The following protocol has been defined:

Data transfer may be initiated only when the bus is not busy.

During data transfer, the data line must remain stable whenever the clock line is HIGH. Changes in the data line while the clock line is HIGH will be interpreted as control signals.

Accordingly, the following bus conditions have been defined:

**Bus Not Busy** — both data and clock lines remain HIGH.

**Start Data Transfer** — a change in the state of the data line, from HIGH to LOW, while the clock is HIGH defines the start condition.

**Stop Data Transfer** — a change in the state of the data line, from LOW to HIGH, defines the stop condition.

**Data Valid** — the state of the data line represents valid data when, after a start condition, the data line is stable for the duration of the HIGH period of the clock signal. The data on the line may be changed during the LOW period of the clock signal. There is one clock pulse per bit of data.

Each data transfer is initiated with a start condition and terminated with a stop condition; the number of the data bytes transferred between the start and stop conditions is limited to two bytes in the ERASE/WRITE mode and unlimited in the READ mode. The information is transmitted in bytes and each receiver acknowledges with a ninth bit.

Within the I<sup>2</sup>C bus specifications a low-speed mode (2kHz clock rate) and a high-speed mode (100kHz clock rate) are defined. The PCF8582A works in both modes. By definition a device that gives out a signal is called a "transmitter," and the device which receives the signal is called a "receiver". The device which controls the signal is called the "master". The devices that are controlled by the master are called "slaves".

Each word of eight bits is followed by one acknowledge bit. This acknowledge bit is a HIGH level put on the bus by the transmitter

whereas the master generates an extra acknowledge-related clock pulse. A slave receiver which it addresses is obliged to generate an acknowledge after the reception of each byte.

Also, a master receiver must generate an acknowledge after the reception of each byte that has been clocked out of the slave transmitter.

The device that acknowledges has to pull down the SDA line during the acknowledge clock pulse in such a way that the SDA line is stable LOW during the high period of the acknowledge related clock pulse.

Setup and hold times must be taken into account. A master receiver must signal an end-of-data to the slave transmitter by not generating an acknowledge on the last byte that has been clocked out of the slave. In this case the transmitter must leave the data line HIGH to enable the master generation of the stop condition.

#### I<sup>2</sup>C Bus Protocol

The I<sup>2</sup>C bus configuration for different READ and WRITE cycles of the PCF8582A are shown in Figures 1a and 1b.

# Static CMOS EEPROM

## PCF8582A

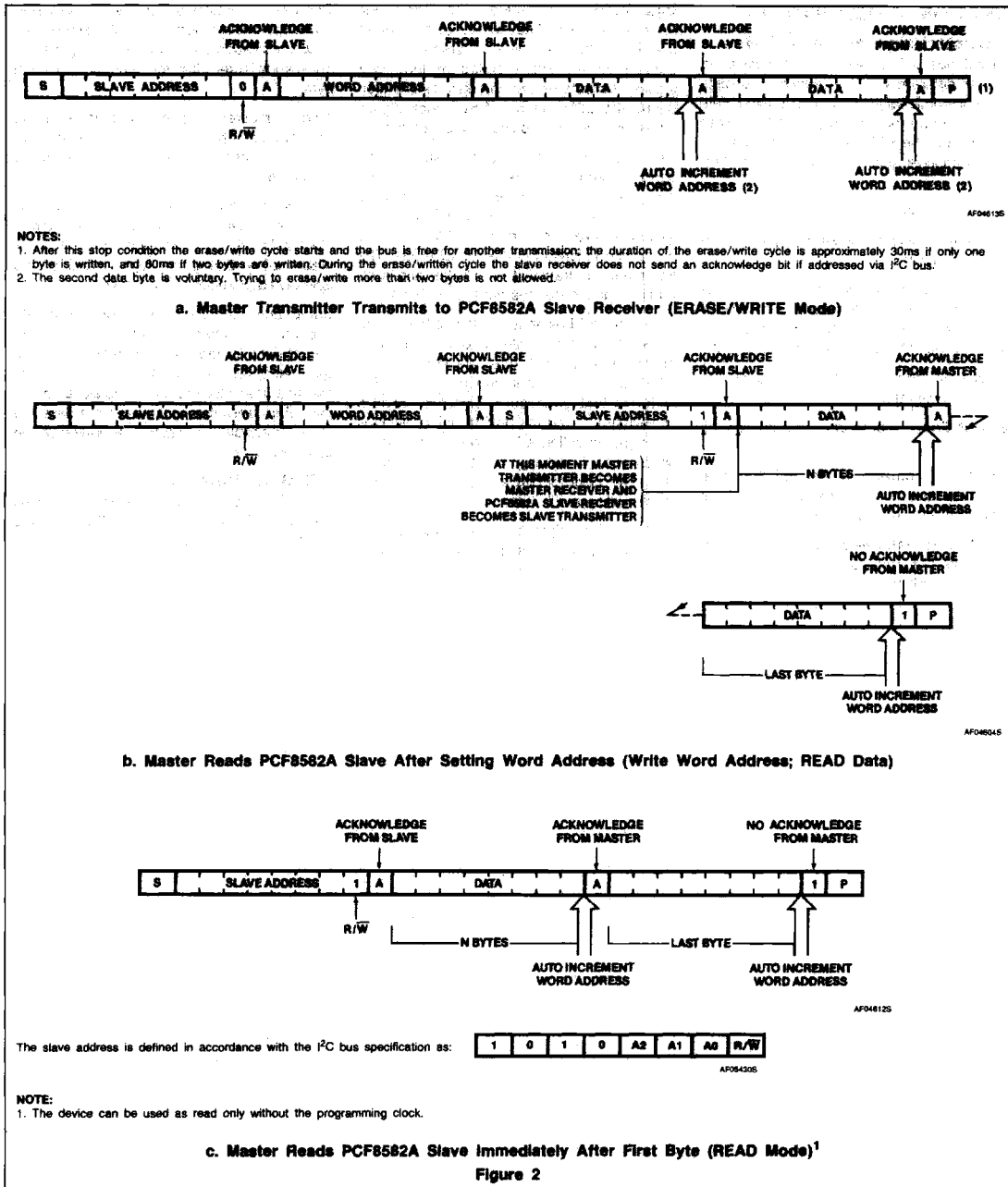

## Static CMOS EEPROM

PCF8582A

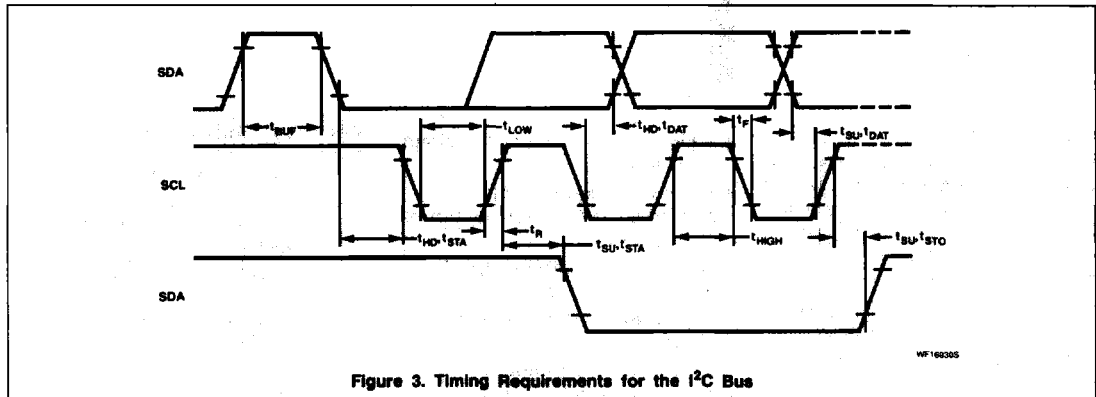
I<sup>2</sup>C BUS TIMINGFigure 3. Timing Requirements for the I<sup>2</sup>C Bus