



SINGLE BUFFER (OPEN DRAIN)



- HIGH SPEED: $t_{PD} = 6.1 \text{ ns}$ (TYP.) at $V_{CC} = 5V$
- LOW POWER DISSIPATION:
 $I_{CC} = 1 \mu\text{A}$ (MAX.) at $T_A = 25^\circ\text{C}$
- HIGH NOISE IMMUNITY:
 $V_{NIH} = V_{NIL} = 28\% V_{CC}$ (MIN.)
- POWER DOWN PROTECTION ON INPUT
- OPERATING VOLTAGE RANGE:
 $V_{CC} \text{ (OPR)} = 2V \text{ to } 5.5V$
- IMPROVED LATCH-UP IMMUNITY

DESCRIPTION

The 74V1G07 is an advanced high-speed CMOS SINGLE BUFFER (OPEN DRAIN) fabricated with sub-micron silicon gate and double-layer metal wiring C²MOS technology.

The internal circuit is composed of 2 stages including buffer output, which provide high noise immunity and stable output.

PRELIMINARY DATA

	
S	C
(SOT23-5L)	(SC-70)
ORDER CODE:	
74V1G07S	74V1G07C

Power down protection is provided on input and 0 to 7V can be accepted on input with no regard to the supply voltage. This device can be used to interface 5V to 3V.

PIN CONNECTION AND IEC LOGIC SYMBOLS

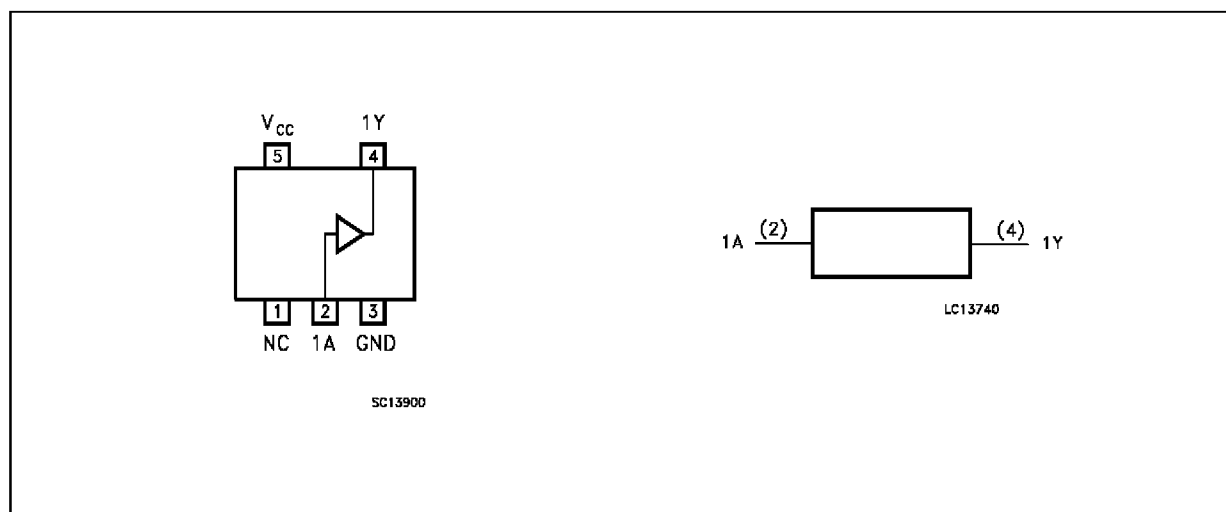

INPUT EQUIVALENT CIRCUIT

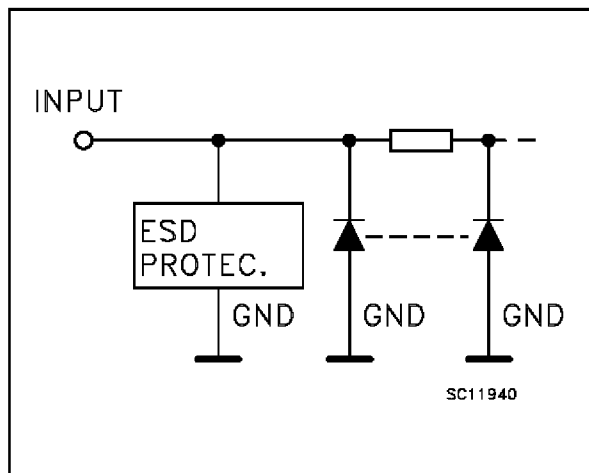

PIN DESCRIPTION

PIN No	SYMBOL	NAME AND FUNCTION
1	N.C.	Not Connected
2	1A	Data Input
4	1Y	Data Output
3	GND	Ground (0V)
5	V _{CC}	Positive Supply Voltage

TRUTH TABLE

A	Y
L	L
H	Z

Z = High impedance

ABSOLUTE MAXIMUM RATINGS

Symbol	Parameter	Value	Unit
V _{CC}	Supply Voltage	-0.5 to +7.0	V
V _I	DC Input Voltage	-0.5 to +7.0	V
V _O	DC Output Voltage	-0.5 to V _{CC} + 0.5	V
I _{IK}	DC Input Diode Current	- 20	mA
I _{OK}	DC Output Diode Current	± 20	mA
I _O	DC Output Current	± 25	mA
I _{CC} or I _{GND}	DC V _{CC} or Ground Current	± 50	mA
T _{stg}	Storage Temperature	-65 to +150	°C
T _L	Lead Temperature (10 sec)	260	°C

Absolute Maximum Ratings are those values beyond which damage to the device may occur. Functional operation under these condition is not implied.

RECOMMENDED OPERATING CONDITIONS

Symbol	Parameter	Value	Unit
V _{CC}	Supply Voltage	2.0 to 5.5	V
V _I	Input Voltage	0 to 5.5	V
V _O	Output Voltage	0 to V _{CC}	V
T _{op}	Operating Temperature	-40 to +85	°C
dt/dv	Input Rise and Fall Time (see note 1) (V _{CC} = 3.3 ± 0.3V) (V _{CC} = 5.0 ± 0.5V)	0 to 100 0 to 20	ns/V ns/V

1) V_{IN} from 30% to 70% of V_{CC}

DC SPECIFICATIONS

Symbol	Parameter	Test Conditions		Value					Unit
				T _A = 25 °C			-40 to 85 °C		
				Min.	Typ.	Max.	Min.	Max.	
V _{IH}	High Level Input Voltage	2.0		1.5			1.5		V
		3.0 to 5.5		0.7V _{CC}			0.7V _{CC}		
V _{IL}	Low Level Input Voltage	2.0				0.5		0.5	V
		3.0 to 5.5				0.3V _{CC}		0.3V _{CC}	
V _{OL}	Low Level Output Voltage	2.0	I _O =50 μA		0.0	0.1		0.1	V
		3.0	I _O =50 μA		0.0	0.1		0.1	
		4.5	I _O =50 μA		0.0	0.1		0.1	
		3.0	I _O =4 mA			0.36		0.44	
		4.5	I _O =8 mA			0.36		0.44	
I _{OZ}	High Impedance Output Leakage Current	5.5	V _I = V _{IH} or V _{IL} V _O = V _{CC} or GND			±0.25		±2.5	μA
I _I	Input Leakage Current	0 to 5.5	V _I = 5.5V or GND			±0.1		±1.0	μA
I _{CC}	Quiescent Supply Current	5.5	V _I = V _{CC} or GND			1		10	μA

AC ELECTRICAL CHARACTERISTICS (Input t_r = t_f = 3 ns)

Symbol	Parameter	Test Condition			Value					Unit
					T _A = 25 °C			-40 to 85 °C		
					Min.	Typ.	Max.	Min.	Max.	
t _{PLH} t _{PHL}	Propagation Delay Time	3.3 ^(*)	15			7.0	9.7	1.0	11.5	ns
		3.3 ^(*)	50			9.5	13.2	1.0	15.0	
		5.0 ^(**)	15			4.6	6.8	1.0	8.0	
		5.0 ^(**)	50			6.1	8.8	1.0	10.0	

(*) Voltage range is 3.3V ± 0.3V

(**) Voltage range is 5V ± 0.5V

CAPACITIVE CHARACTERISTICS

Symbol	Parameter	Test Conditions		Value					Unit
				T _A = 25 °C			-40 to 85 °C		
				Min.	Typ.	Max.	Min.	Max.	
C _{IN}	Input Capacitance			4	10			10	pF
C _{PD}	Power Dissipation Capacitance (note 1)			11					pF

1) C_{PD} is defined as the value of the IC's internal equivalent capacitance which is calculated from the operating current consumption without load. (Refer to Test Circuit). Average operating current can be obtained by the following equation. I_{CC(oper)} = C_{PD} • V_{CC} • f_{IN} + I_{CC}

TEST CIRCUIT

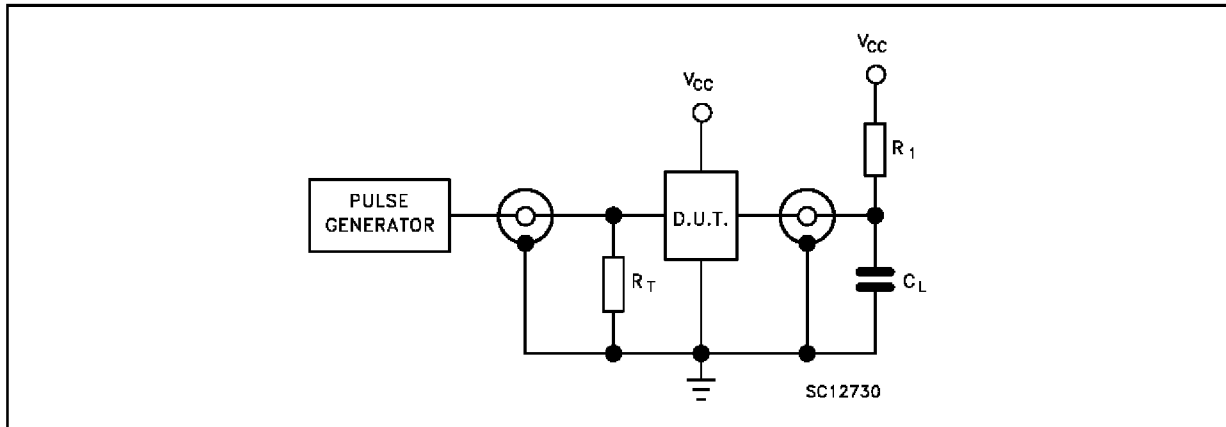

$C_L = 15/50$ pF or equivalent (includes jig and probe capacitance)
 $R_L = R_1 = 1K\Omega$ or equivalent
 $R_T = Z_{out}$ of pulse generator (typically 50Ω)

WAVEFORM: PROPAGATION DELAYS ($f=1MHz$; 50% duty cycle)

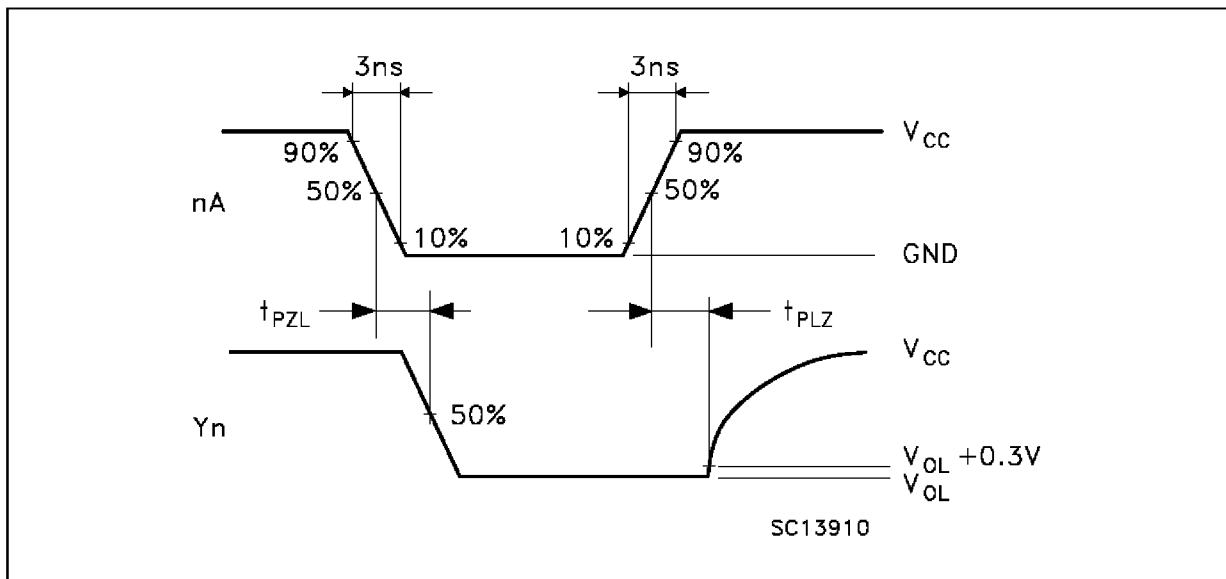

SOT23-5L MECHANICAL DATA

DIM.	mm			mils		
	MIN.	TYP.	MAX.	MIN.	TYP.	MAX.
A	0.90		1.45	35.4		57.1
A1	0.00		0.15	0.0		5.9
A2	0.90		1.30	35.4		51.2
b	0.35		0.50	13.7		19.7
C	0.09		0.20	3.5		7.8
D	2.80		3.00	110.2		118.1
E	2.60		3.00	102.3		118.1
E1	1.50		1.75	59.0		68.8
L	0.35		0.55	13.7		21.6
e		0.95			37.4	
e1		1.9			74.8	

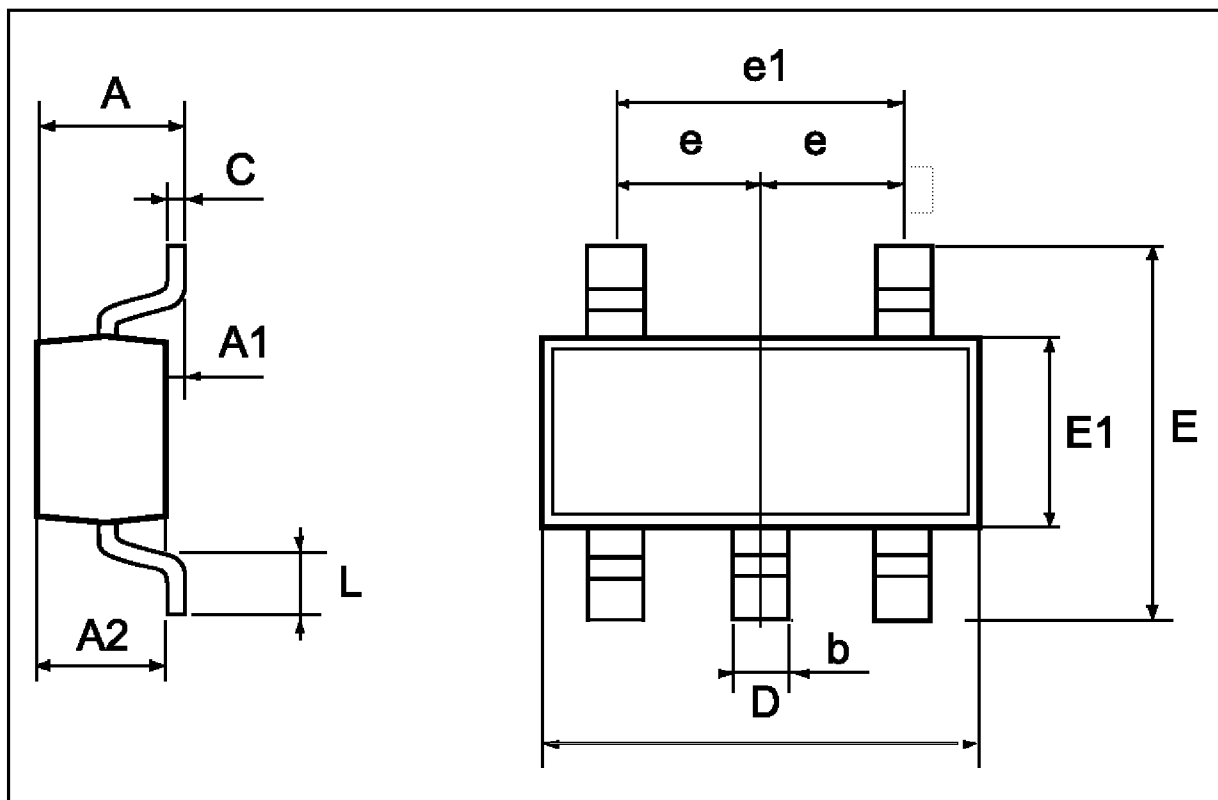

SC-70 MECHANICAL DATA

DIM.	mm			mils		
	MIN.	TYP.	MAX.	MIN.	TYP.	MAX.
A	0.80		1.10	31.5		43.3
A1	0.00		0.10	0.0		3.9
A2	0.80		1.00	31.5		39.4
b	0.15		0.30	5.9		11.8
C	0.10		0.18	3.9		7.1
D	1.80		2.20	70.9		86.6
E	1.80		2.40	70.9		94.5
E1	1.15		1.35	45.3		53.1
L	0.10		0.30	3.9		11.8
e		0.65			25.6	
e1		1.3			51.2	

