

SILICON PLANAR EPITAXIAL SWITCHING TRANSISTOR

N-P-N transistor in a plastic TO-92 envelope intended for high-speed switching applications.

QUICK REFERENCE DATA

Collector-base voltage (open emitter)	V_{CBO}	max.	40 V
Collector-emitter voltage ($V_{BE} = 0$)	V_{CES}	max.	40 V
Collector-emitter voltage (open base)	V_{CEO}	max.	15 V
Collector current (peak value)	I_{CM}	max.	500 mA
Total power dissipation up to $T_{amb} = 25\text{ }^{\circ}\text{C}$	P_{tot}	max.	500 mW
D.C. current gain			
$I_C = 10\text{ mA}; V_{CE} = 1\text{ V}$	PH2369	h_{FE}	40 to 120
$I_C = 10\text{ mA}; V_{CE} = 0.35\text{ V}$	PH2369A	h_{FE}	40 to 120
Transition frequency at $f = 100\text{ MHz}$			
$I_C = 10\text{ mA}; V_{CE} = 10\text{ V}$	f_T	>	500 MHz
Storage time			
$I_{Con} = I_{Bon} = -I_{Boff} = 10\text{ mA}$	t_s	<	13 ns

MECHANICAL DATA

Dimensions in mm

Fig. 1 TO-92.

Pinning

- 1 = emitter
- 2 = base
- 3 = collector

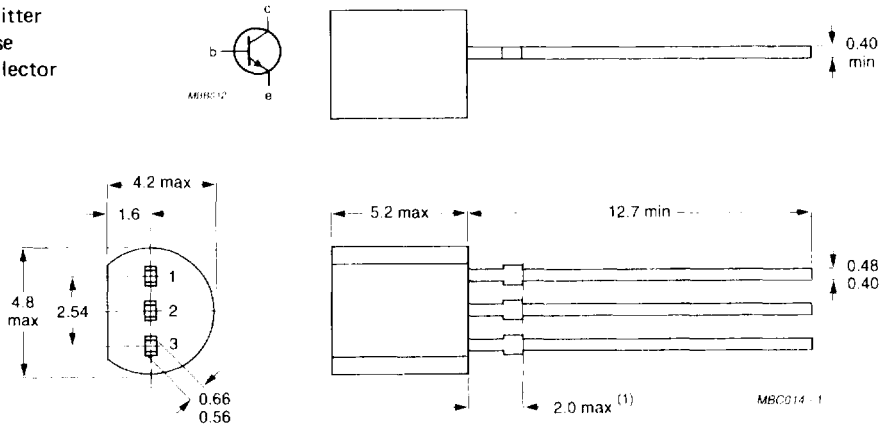

Note (1) Terminal dimensions within this zone are uncontrolled to allow for flow of plastic and terminal irregularities.

RATINGS

Limiting values in accordance with the Absolute Maximum System (IEC 134)

Collector-base voltage (open emitter)	V_{CBO}	max.	40 V
Collector emitter voltage ($V_{BE} = 0$)	V_{CES}	max.	40 V
Collector-emitter voltage (open base)	V_{CEO}	max.	15 V
Emitter-base voltage (open collector)	V_{EBO}	max.	4,5 V
Collector current (peak value; $t_p = 10 \mu s$)	I_{CM}	max.	500 mA
Total power dissipation up to $T_{amb} = 25 \text{ }^\circ\text{C}$	P_{tot}	max.	500 mW
Storage temperature range	T_{stg}		-65 to + 150 $^\circ\text{C}$
Junction temperature	T_j	max.	150 $^\circ\text{C}$

THERMAL RESISTANCE

From junction to ambient in free air	$R_{th j-a}$	=	250 K/W
--------------------------------------	--------------	---	---------

CHARACTERISTICS

$T_{amb} = 25 \text{ }^\circ\text{C}$ unless otherwise specified

Collector cut off current

$I_E = 0; V_{CB} = 20 \text{ V}$	I_{CBO}	<	400 nA
$I_E = 0; V_{CB} = 20 \text{ V}; T_j = 125 \text{ }^\circ\text{C}$	I_{CBO}	<	30 μA

Emitter cut off current

$I_C = 0; V_{EB} = 2 \text{ V}$	I_{EBO}	<	100 nA
---------------------------------	-----------	---	--------

Saturation voltages

$I_C = 10 \text{ mA}; I_B = 1 \text{ mA}$	PH2369	V_{CEsat}	max.	0,25 V
$I_C = 10 \text{ mA}; I_B = 1 \text{ mA}$		V_{BEsat}	min.	0,70 V
$I_C = 10 \text{ mA}; I_B = 1 \text{ mA}$	PH2369A	V_{BEsat}	max.	0,85 V
$I_C = 10 \text{ mA}; I_B = 1 \text{ mA}$		V_{CEsat}	<	0,20 V
$I_C = 30 \text{ mA}; I_B = 3 \text{ mA}$		V_{CEsat}	<	0,25 V
$I_C = 100 \text{ mA}; I_B = 10 \text{ mA}$		V_{CEsat}	<	0,50 V
$I_C = 10 \text{ mA}; I_B = 10 \text{ mA}$		V_{CEsat}	<	0,30 V
$I_C = 10 \text{ mA}; I_B = 1 \text{ mA}$		V_{BEsat}	min.	0,70 V
		V_{BEsat}	max.	0,85 V

D.C. current gain

$I_C = 10 \text{ mA}; V_{CE} = 1 \text{ V}$	PH2369	h_{FE}		40 to 120
$I_C = 10 \text{ mA}; V_{CE} = 1 \text{ V}; T_{amb} = -55 \text{ }^\circ\text{C}$		h_{FE}	>	20
$I_C = 100 \text{ mA}; V_{CE} = 2 \text{ V}$		h_{FE}	>	20
$I_C = 10 \text{ mA}; V_{CE} = 0,35 \text{ V}$	PH2369A	h_{FE}	>	40 to 120
$I_C = 30 \text{ mA}; V_{CE} = 0,4 \text{ V}$		h_{FE}	>	30
$I_C = 100 \text{ mA}; V_{CE} = 1 \text{ V}$		h_{FE}	>	20
$I_C = 10 \text{ mA}; V_{CE} = 0,35 \text{ V}; T_{amb} = -55 \text{ }^\circ\text{C}$		h_{FE}	>	20
		h_{FE}	>	20

Transition frequency at $f = 100 \text{ MHz}$

$I_C = 10 \text{ mA}; V_{CE} = 10 \text{ V}$	f_T	>	500 MHz
--	-------	---	---------

Collector capacitance at $f = 1 \text{ MHz}$

$I_E = I_B = 0; V_{CB} = 5 \text{ V}$	C_c	<	4 pF
---------------------------------------	-------	---	------

Emitter capacitance at $f = 1 \text{ MHz}$
 $I_C = I_C = 0; V_{EB} = 1 \text{ V}$

$C_e < 4,5 \text{ pF}$

Switching times

Storage time (see Fig. 2)

$I_{Con} = I_{Bon} = -I_{Boff} = 10 \text{ mA}$

$t_s \text{ typ. } 6 \text{ ns}$
 $< 13 \text{ ns}$

Pulse generator:

$t_r < 1 \text{ ns}$

$t_p > 300 \text{ ns}$

$\delta < 0,02$

$R_s = 50 \Omega$

Oscilloscope:

$R_i = 50 \Omega$

$t_r < 1 \text{ ns}$

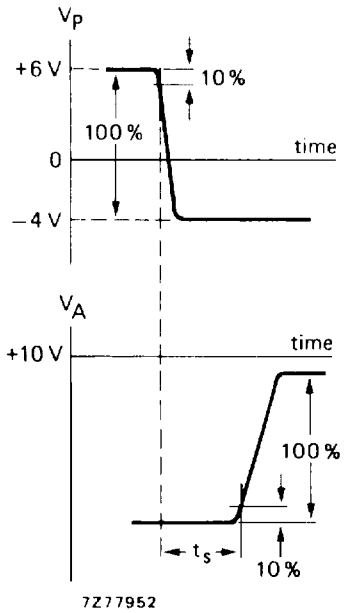
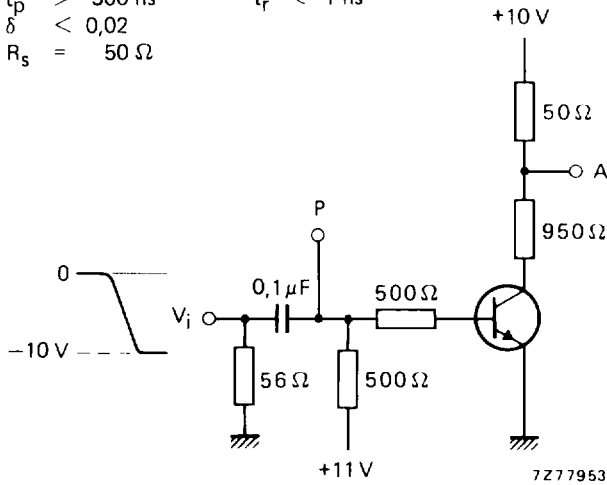

Fig. 2 Test circuit and waveforms.

Turn-on time (see Fig. 3)

from $-V_{BEoff} = 1,5 \text{ V}$ to $I_{Con} = 10 \text{ mA}; I_{Bon} = 3 \text{ mA}$

from $-V_{BEoff} = 2,25 \text{ V}$ to $I_{Con} = 100 \text{ mA}; I_{Bon} = 40 \text{ mA}$

$t_{on} < 12 \text{ ns}$

$t_{on} < 7 \text{ ns}$

Turn-off time (see Fig. 3)

$i_{Con} = 10 \text{ mA}; I_{Bon} = 3 \text{ mA}; -I_{Boff} = 1,5 \text{ mA}$

$I_{Con} = 100 \text{ mA}; I_{Bon} = 40 \text{ mA}; -I_{Boff} = 20 \text{ mA}$

$t_{off} < 18 \text{ ns}$

$t_{off} < 21 \text{ ns}$

Pulse generator:

- $t_r < 1 \text{ ns}$
- $t_p > 300 \text{ ns}$
- $\delta < 0,02$
- $R_s = 50 \Omega$

Oscilloscope:

- $R_i = 50 \Omega$
- $t_r < 1 \text{ ns}$

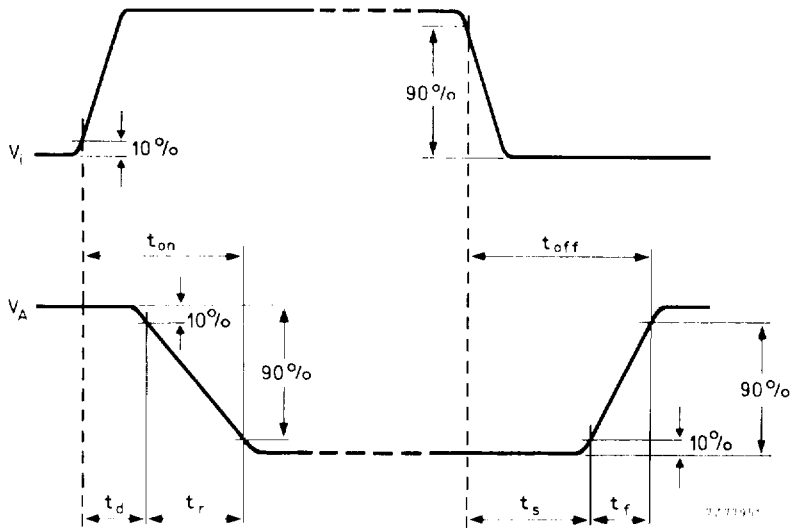
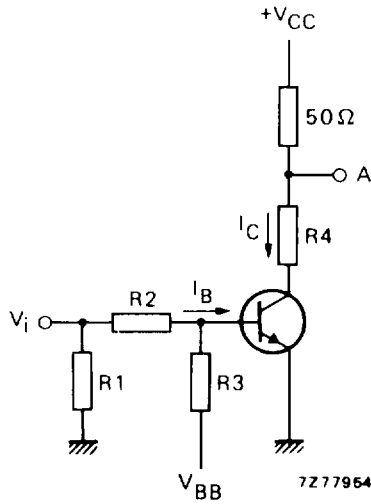

Fig. 3 Test circuit and waveforms.

I_{Con} mA	I_{Bon} mA	I_{Boff} mA	V_{CC} V	R_1 Ω	$R_2; R_3$ k Ω	R_4 Ω	turn-on time			turn-off time	
							V_{BB} V	V_{BE} V	V_i V	V_{BB} V	V_i V
10	3	-1,5	3	50	3,30	220	-3,0	-1,50	15	12,0	-15
100	40	-20	6	56	0,33	0	-4,5	-2,25	20	15,3	-20