

T-46-07-11

574



54AC/74AC574 • 54ACT/74ACT574

Octal D-Type Flip-Flop with TRI-STATE® Outputs

General Description

The 'AC/'ACT574 is a high-speed, low power octal flip-flop with a buffered common Clock (CP) and a buffered common Output Enable (\overline{OE}). The information presented to the D inputs is stored in the flip-flops on the LOW-to-HIGH Clock (CP) transition.

The 'AC/'ACT574 is functionally identical to the 'AC/'ACT374 except for the pinouts.

Features

- I_{CC} and I_{OZ} reduced by 50%
- Inputs and outputs on opposite sides of package allowing easy interface with microprocessors
- Useful as input or output port for microprocessors
- Functionally identical to 'AC/'ACT374
- TRI-STATE outputs for bus-oriented applications
- Outputs source/sink 24 mA
- 'ACT574 has TTL-compatible inputs
- Standard Military Drawing (SMD) — 'ACT574: 5962-89601

Ordering Code: See Section 8

Logic Symbols

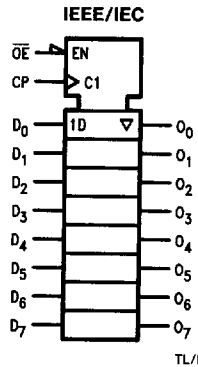
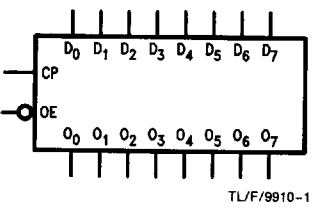

Connection Diagrams

Pin Assignment for DIP, Flatpak and SOIC

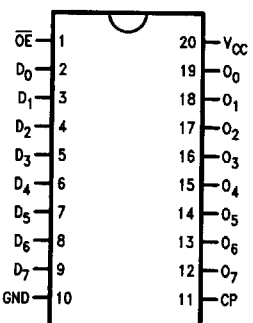

Pin Assignment for LCC

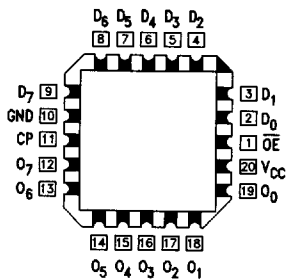

Pin Names	Description
D ₀ -D ₇	Data Inputs
CP	Clock Pulse Input
\overline{OE}	TRI-STATE Output Enable Input
O ₀ -O ₇	TRI-STATE Outputs

Functional Description

The 'AC/'ACT574 consists of eight edge-triggered flip-flops with individual D-type inputs and TRI-STATE true outputs. The buffered clock and buffered Output Enable are common to all flip-flops. The eight flip-flops will store the state of their individual D inputs that meet the setup and hold time requirements on the LOW-to-HIGH Clock (CP) transition. With the Output Enable (\overline{OE}) LOW, the contents of the eight flip-flops are available at the outputs. When \overline{OE} is HIGH, the outputs go to the high impedance state. Operation of the \overline{OE} input does not affect the state of the flip-flops.

Function Table

Inputs			Internal	Outputs	Function
\overline{OE}	CP	D	Q	O_N	
H	H	L	NC	Z	Hold
H	H	H	NC	Z	Hold
H	↗	L	L	Z	Load
H	↗	H	H	Z	Load
L	↗	L	L	L	Data Available
L	↗	H	H	H	Data Available
L	H	L	NC	NC	No Change in Data
L	H	H	NC	NC	No Change in Data

H = HIGH Voltage Level
 L = LOW Voltage Level
 X = Immaterial
 Z = High Impedance
 ↗ = LOW-to-HIGH Transition
 NC = No Change

Logic Diagram

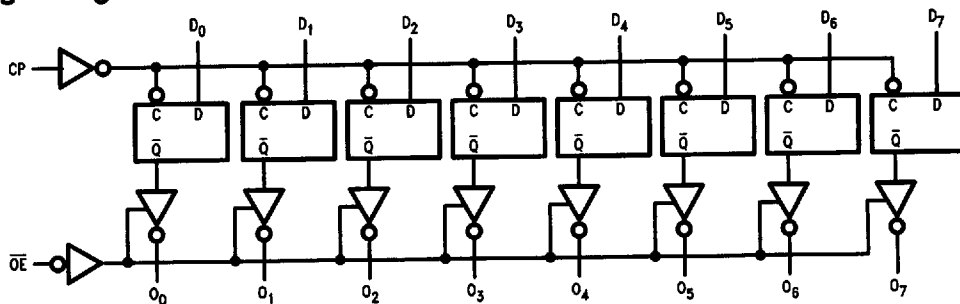

TL/F/8910-5

Please note that this diagram is provided only for the understanding of logic operations and should not be used to estimate propagation delays.

Absolute Maximum Ratings (Note 1)

If Military/Aerospace specified devices are required, please contact the National Semiconductor Sales Office/Distributors for availability and specifications.

Supply Voltage (V _{CC})	-0.5V to +7.0V
DC Input Diode Current (I _{IK})	
V _I = -0.5V	-20 mA
V _I = V _{CC} + 0.5V	+20 mA
DC Input Voltage (V _I)	-0.5V to V _{CC} + 0.5V
DC Output Diode Current (I _{OK})	
V _O = -0.5V	-20 mA
V _O = V _{CC} + 0.5V	+20 mA
DC Output Voltage (V _O)	-0.5V to V _{CC} + 0.5V
DC Output Source or Sink Current (I _O)	±50 mA
DC V _{CC} or Ground Current	
Per Output Pin (I _{CC} or I _{GND})	±50 mA
Storage Temperature (T _{STG})	-65°C to +150°C
Junction Temperature (T _J)	
CDIP	175°C
PDIP	140°C

Note 1: Absolute maximum ratings are those values beyond which damage to the device may occur. The databook specifications should be met, without exception, to ensure that the system design is reliable over its power supply, temperature, and output/input loading variables. National does not recommend operation of FACT™ circuits outside databook specifications.

Recommended Operating Conditions

Supply Voltage (V _{CC})	(Unless Otherwise Specified) (AC)	2.0V to 6.0V
	(ACT)	4.5V to 5.5V
Input Voltage (V _I)		0V to V _{CC}
Output Voltage (V _O)		0V to V _{CC}
Operating Temperature (T _A)		
74AC/ACT		-40°C to +85°C
54AC/ACT		-55°C to +125°C
Minimum Input Edge Rate (ΔV/Δt)		
'AC Devices		
V _{IN} from 30% to 70% of V _{CC}		
V _{CC} @ 3.3V, 4.5V, 5.5V		125 mV/ns
Minimum Input Edge Rate (ΔV/Δt)		
'ACT Devices		
V _{IN} from 0.8V to 2.0V		
V _{CC} @ 4.5V, 5.5V		125 mV/ns

DC Characteristics for 'AC Family Devices

Symbol	Parameter	V _{CC} (V)	74AC		54AC	74AC	Units	Conditions	
			T _A = 25°C		T _A = -55°C to +125°C	T _A = -40°C to +85°C			
			Typ		Guaranteed Limits				
V _{IH}	Minimum High Level Input Voltage	3.0	1.5	2.1	2.1	2.1	V	V _{OUT} = 0.1V or V _{CC} - 0.1V	
		4.5	2.25	3.15	3.15	3.15			
		5.5	2.75	3.85	3.85	3.85			
V _{IL}	Maximum Low Level Input Voltage	3.0	1.5	0.9	0.9	0.9	V	V _{OUT} = 0.1V or V _{CC} - 0.1V	
		4.5	2.25	1.35	1.35	1.35			
		5.5	2.75	1.65	1.65	1.65			
V _{OH}	Minimum High Level Output Voltage	3.0	2.99	2.9	2.9	2.9	V	I _{OUT} = -50 μA	
		4.5	4.49	4.4	4.4	4.4			
		5.5	5.49	5.4	5.4	5.4			
			3.0		2.56	2.4	2.46	V	*V _{IN} = V _{IL} or V _{IH} -12 mA I _{OH} -24 mA -24 mA
			4.5		3.86	3.7	3.76		
			5.5		4.86	4.7	4.76		
V _{OL}	Maximum Low Level Output Voltage	3.0	0.002	0.1	0.1	0.1	V	I _{OUT} = 50 μA	
		4.5	0.001	0.1	0.1	0.1			
		5.5	0.001	0.1	0.1	0.1			
			3.0		0.36	0.50	0.44	V	*V _{IN} = V _{IL} or V _{IH} 12 mA I _{OL} 24 mA 24 mA
			4.5		0.36	0.50	0.44		
			5.5		0.36	0.50	0.44		
I _{IN}	Maximum Input Leakage Current	5.5		±0.1	±1.0	±1.0	μA	V _I = V _{CC} , GND	

*All outputs loaded; thresholds on input associated with output under test.

DC Characteristics for 'AC Family Devices (Continued)

Symbol	Parameter	V _{CC} (V)	74AC		54AC		74AC		Units	Conditions
			T _A = 25°C		T _A = -55°C to +125°C		T _A = -40°C to +85°C			
			Typ	Guaranteed Limits						
I _{OZ}	Maximum TRI-STATE Leakage Current	5.5		±0.25		±5.0		±2.5	μA	V _I (OE) = V _{IL} , V _{IH} V _I = V _{CC} , V _{GND} V _O = V _{CC} , GND
I _{OLD}	†Minimum Dynamic Output Current	5.5				50		75	mA	V _{OLD} = 1.65V
I _{OHD}		5.5				-50		-75	mA	V _{OHD} = 3.85V
I _{CC}	Maximum Quiescent Supply Current	5.5		4.0		80.0		40.0	μA	V _{IN} = V _{CC} or GND

†Maximum test duration 2.0 ms, one output loaded at a time.

Note: I_{IN} and I_{CC} @ 3.0V are guaranteed to be less than or equal to the respective limit @ 5.5V V_{CC}.
I_{CC} for 54AC @ 25°C is identical to 74AC @ 25°C.

DC Characteristics for 'ACT Family Devices

Symbol	Parameter	V _{CC} (V)	74ACT		54ACT		74ACT		Units	Conditions
			T _A = 25°C		T _A = -55°C to +125°C		T _A = -40°C to +85°C			
			Typ	Guaranteed Limits						
V _{IH}	Minimum High Level Input Voltage	4.5	1.5	2.0		2.0		2.0	V	V _{OUT} = 0.1V or V _{CC} - 0.1V
		5.5	1.5	2.0		2.0		2.0		
V _{IL}	Maximum Low Level Input Voltage	4.5	1.5	0.8		0.8		0.8	V	V _{OUT} = 0.1V or V _{CC} - 0.1V
		5.5	1.5	0.8		0.8		0.8		
V _{OH}	Minimum High Level	4.5	4.49	4.4		4.4		4.4	V	I _{OUT} = -50 μA
		5.5	5.49	5.4		5.4		5.4		
		4.5		3.86		3.70		3.76	V	*V _{IN} = V _{IL} or V _{IH} I _{OH} = -24 mA -24 mA
		5.5		4.86		4.70		4.76		
V _{OL}	Maximum Low Level Output Voltage	4.5	0.001	0.1		0.1		0.1	V	I _{OUT} = 50 μA
		5.5	0.001	0.1		0.1		0.1		
		4.5		0.36		0.50		0.44	V	*V _{IN} = V _{IL} or V _{IH} I _{OL} = 24 mA 24 mA
		5.5		0.36		0.50		0.44		
I _{IN}	Maximum Input Leakage Current	5.5		±0.1		±1.0		±1.0	μA	V _I = V _{CC} , GND
I _{OZ}	Maximum TRI-STATE Leakage Current	5.5		±0.25		±5.0		±2.5	μA	V _I = V _{IL} , V _{IH} V _O = V _{CC} , GND
I _{CC1}	Maximum I _{CC} /Input	5.5	0.6			1.6		1.5	mA	V _I = V _{CC} - 2.1V
I _{OLD}	†Minimum Dynamic Output Current	5.5				50		75	mA	V _{OLD} = 1.65V
I _{OHD}		5.5				-50		-75	mA	V _{OHD} = 3.85V
I _{CC}	Maximum Quiescent Supply Current	5.5		4.0		80.0		40.0	μA	V _{IN} = V _{CC} or GND

*All outputs loaded; thresholds on input associated with output under test.

†Maximum test duration 2.0 ms, one output loaded at a time.

Note: I_{CC} for 54ACT @ 25°C is identical to 74ACT @ 25°C.

AC Electrical Characteristics: See Section 2 for Waveforms

Symbol	Parameter	V _{CC} * (V)	74AC			54AC		74AC		Units	Fig. No.
			T _A = +25°C C _L = 50 pF			T _A = -55°C to +125°C C _L = 50 pF		T _A = -40°C to +85°C C _L = 50 pF			
			Min	Typ	Max	Min	Max	Min	Max		
f _{MAX}	Maximum Clock Frequency	3.3 5.0	75 95	112 153		55 85		60 85	MHz		
t _{PLH}	Propagation Delay CP to O _n	3.3 5.0	3.5 2.0	8.5 6.0	13.5 9.5	1.0 1.5	16.5 11.5	3.5 2.0	15.0 11.0	ns	2-3, 4
t _{PHL}	Propagation Delay CP to O _n	3.3 5.0	3.5 2.0	7.5 5.5	12.0 8.5	1.0 1.5	15.0 10.5	3.5 2.0	13.5 9.5	ns	2-3, 4
t _{PZH}	Output Enable Time	3.3 5.0	2.5 2.0	7.0 5.0	11.0 8.5	1.0 1.5	13.0 9.5	2.5 2.0	12.0 9.0	ns	2-5
t _{PZL}	Output Enable Time	3.3 5.0	3.0 2.0	6.5 5.0	10.5 8.0	1.0 1.5	12.5 9.5	3.0 1.5	11.5 9.0	ns	2-6
t _{PHZ}	Output Disable Time	3.3 5.0	3.5 2.0	7.5 6.0	12.0 9.5	1.0 1.5	14.0 11.5	2.5 1.5	13.0 10.5	ns	2-5
t _{PLZ}	Output Disable Time	3.3 5.0	2.0 1.0	5.5 4.5	9.0 7.5	1.0 1.5	10.5 9.0	1.5 1.0	10.0 8.5	ns	2-6

*Voltage Range 3.3 is 3.3V ± 0.3V
Voltage Range 5.0 is 5.0V ± 0.5V

AC Operating Requirements: See Section 2 for Waveforms

Symbol	Parameter	V _{CC} * (V)	74AC		54AC		74AC		Units	Fig. No.
			T _A = +25°C C _L = 50 pF		T _A = -55°C to +125°C C _L = 50 pF		T _A = -40°C to +85°C C _L = 50 pF			
			Typ	Guaranteed Minimum						
t _s	Set-Up Time, HIGH or LOW D _n to CP	3.3 5.0	0.5 0	2.5 1.5	4.5 3.5	3.0 2.0			ns	2-7
t _h	Hold Time, HIGH or LOW D _n to CP	3.3 5.0	-0.5 0	1.5 1.5	2.5 2.5	1.5 1.5			ns	2-7
t _w	CP Pulse Width HIGH or LOW	3.3 5.0	3.5 2.0	6.0 4.0	7.5 5.0	7.0 5.0			ns	2-4

*Voltage Range 3.3 is 3.3V ± 0.3V
Voltage Range 5.0 is 5.0V ± 0.5V

574

AC Electrical Characteristics: See Section 2 for Waveforms

Symbol	Parameter	V _{CC} * (V)	74ACT			54ACT		74ACT		Units	Fig. No.
			T _A = +25°C C _L = 50 pF			T _A = -55°C to +125°C C _L = 50 pF		T _A = -40°C to +85°C C _L = 50 pF			
			Min	Typ	Max	Min	Max	Min	Max		
f _{MAX}	Maximum Clock Frequency	5.0	100	110		70		85	ns		
t _{PLH}	Propagation Delay CP to O _n	5.0	2.5	7.0	11.0	1.5	13.5	2.0	12.0	ns	2-3, 4
t _{PHL}	Propagation Delay CP to O _n	5.0	2.0	6.5	10.0	1.5	12.5	1.5	11.0	ns	2-3, 4
t _{PZH}	Output Enable Time	5.0	2.0	6.4	9.5	1.5	11.0	1.5	10.0	ns	2-5
t _{PZL}	Output Enable Time	5.0	2.0	6.0	9.0	1.5	11.0	1.5	10.0	ns	2-6
t _{PHZ}	Output Disable Time	5.0	2.0	7.0	10.5	1.5	12.0	1.5	11.5	ns	2-5
t _{PLZ}	Output Disable Time	5.0	2.0	5.5	8.5	1.5	10.0	1.5	9.0	ns	2-6

*Voltage Range 5.0 is 5.0V ±0.5V

AC Operating Requirements: See Section 2 for Waveforms

Symbol	Parameter	V _{CC} * (V)	74ACT		54ACT		74ACT		Units	Fig. No.
			T _A = +25°C C _L = 50 pF		T _A = -55°C to +125°C C _L = 50 pF		T _A = -40°C to +85°C C _L = 50 pF			
			Typ	Guaranteed Minimum						
t _s	Set-Up Time, HIGH or LOW D _n to CP	5.0	1.5	2.5	3.5	2.5	ns	2-7		
t _h	Hold Time, HIGH or LOW D _n to CP	5.0	-0.5	1.0	2.0	1.0	ns	2-7		
t _w	CP Pulse Width HIGH or LOW	5.0	2.5	3.0	5.0	4.0	ns	2-4		

*Voltage Range 5.0 is 5.0V ±0.5V

Capacitance

Symbol	Parameter	Typ	Units	Conditions
C _{IN}	Input Capacitance	4.5	pF	V _{CC} = OPEN
C _{PD}	Power Dissipation Capacitance	40.0	pF	V _{CC} = 5.0V