

DM64ALS5245/DM74ALS5245/74ALS5245-1 Octal TRI-STATE® Transceiver

General Description

This octal bus transceiver is designed for asynchronous two-way communication between data buses. The inputs include hysteresis which provides improved noise rejection. Data is transmitted either from the A bus to the B bus or from the B bus to the A bus depending on the logic level of the direction control (DIR) input. The device can be disabled via the enable input (\bar{G}) which causes the outputs to enter the high impedance mode so the buses are effectively isolated. This device offers 64-Industrial grade product guaranteeing performance from -40°C to $+85^{\circ}\text{C}$.

The 'ALS5245-1 features the same performance as the 'ALS5245 with the addition of increased current drive capability to meet the requirements of various bus architectures. The recommended maximum I_{OL} is increased to 48 mA.

Features

- Input Hysteresis
- Low output noise generation
- High input noise immunity
- Advanced oxide-isolated, ion implanted Schottky TTL process
- Switching specification guaranteed over the full temperature and V_{CC} range
- PNP inputs to reduce input loading
- Guaranteed performance over industrial temperature range (-40°C to $+85^{\circ}\text{C}$) in 64-grade products
- Maximum I_{OL} is increased to 48 mA for 'ALS5245-1

Connection Diagram

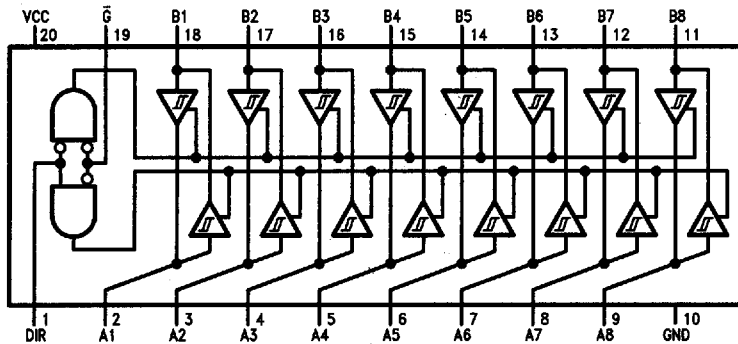

TL/F/9175-1

Order Number DM64ALS5245WM, DM74ALS5245WM, DM74ALS5245SJ,
DM64ALS5245N, DM74ALS5245N, 74ALS5245-1WM, 74ALS5245-1SJ or 74ALS5245-1N
See NS Package Number M20B, M20D or N20A

Function Table

Control Inputs		Operation
\bar{G}	DIR	
L	L	B Data to A Bus
L	H	A Data to B Bus
H	X	High Impedance

L = Low Logic Level, H = High Logic Level
X = Don't Care (Either Low or High Logic Level)

Absolute Maximum Ratings

Supply Voltage	7V
Input Voltage	
Control Inputs	7V
I/O Ports	5.5V
Operating Free-Air Temperature Range	
DM64ALS	-40°C to +85°C
DM74ALS	0°C to +70°C
Storage Temperature Range	-65°C to +150°C

Typical θ_{JA}	
N Package	56.0°C/W
M Package	74.0°C/W

Note: The "Absolute Maximum Ratings" are those values beyond which the safety of the device cannot be guaranteed. The device should not be operated at these limits. The parametric values defined in the "Electrical Characteristics" table are not guaranteed at the absolute maximum ratings. The "Recommended Operating Conditions" table will define the conditions for actual device operation.

Recommended Operating Conditions

Symbol	Parameter	DM64ALS5245		DM74ALS5245		74ALS5245-1		Units
		Min	Max	Min	Max	Min	Max	
V _{CC}	Supply Voltage	4.5	5.5	4.5	5.5	4.5	5.5	V
V _{IH}	High Level Input Voltage	2		2		2		V
V _{IL}	Low Level Input Voltage		0.8		0.8		0.8	V
I _{OH}	High Level Output Current		-15		-15		-15	mA
I _{OL}	Low Level Output Current		24		24		48	mA
T _A	Free Air Operating Temperature Range	-40	85	0	70	0	70	°C

'ALS5245

Electrical Characteristics

over recommended free air temperature range. All typical values are measured at V_{CC} = 5V, T_A = 25°C.

Symbol	Parameter	Test Conditions	DM64ALS5245			DM74ALS5245			Units
			Min	Typ	Max	Min	Typ	Max	
V _{IK}	Input Clamp Voltage	V _{CC} = Min, I _I = -18 mA			-1.5			-1.5	V
H _{YS}	Hysteresis (V _{T+} - V _{T-})	V _{CC} = Min	0.2	0.32		0.2	0.32		V
V _{OH}	High Level Output Voltage	V _{CC} = 4.5V to 5.5V, I _{OH} = -0.4 mA	V _{CC} - 2			V _{CC} - 2			
		V _{CC} = Min, I _{OH} = -3 mA	2.4	3.2		2.4	3.2		V
		I _{OH} = Max	2			2			
V _{OL}	Low Level Output Voltage	V _{CC} = Min, I _{OL} = 12 mA		0.25	0.4		0.25	0.4	
		I _{OL} = 24 mA		0.35	0.5		0.35	0.5	
		V _{CC} = Max, I _I = 100 μ A							
I _I	Input Current at Maximum Input Voltage	V _{CC} = Max			100			100	μ A
		I/O Ports, V _I = 5.5V						100	
		Control Inputs, V _I = 7V			100			100	
I _{IH}	High Level Input Current	V _{CC} = Max, V _I = 2.7V			20			20	μ A
I _{IL}	Low Level Input Current	V _{CC} = Max, V _I = 0.4V			-100			-100	μ A
I _O	Output Drive Current	V _{CC} = Max, V _O = 2.25V	-30		-112	-30		-112	mA
I _{CC}	Supply Current	V _{CC} = Max							
		Outputs High		30	45		30	45	
		Outputs Low		36	55		36	55	
		Outputs Disabled		38	58		38	58	mA
V _{OLP}	Quiet Output Maximum Dynamic V _{OL}	V _{CC} = 5.0V, T _A = 25°C (Figures 1, 2; Notes 1, 2)		0.5			0.5		V
V _{OLV}	Quiet Output Minimum Dynamic V _{OL}	V _{CC} = 5.0V, T _A = 25°C (Figures 1, 2; Notes 1, 2)		-0.2			-0.2		V
V _{IHD}	Minimum High Level Dynamic Input Voltage	V _{CC} = 5.0V, T _A = 25°C (Notes 1, 3)		1.6			1.6		V
V _{ILD}	Maximum Low Level Dynamic Input Voltage	V _{CC} = 5.0V, T _A = 25°C (Notes 1, 3)		1.0			1.0		V

Note 1: Plastic DIP package.

Note 2: n = number of device outputs; n-1 outputs switching, each driven 0V to 3V one output @ GND.

Note 3: n = number of device outputs; n outputs switching, n-1 inputs switching 0V to 3V. Input under test switching 3V to threshold (V_{ILD}); 0V to threshold (V_{IHD}); f = 1 MHz.

Switching Characteristics

over recommended operating free air temperature range (Note 1)

Symbol	Parameter	Conditions	From (Input) To (Output)	DM64ALS5245		DM74ALS5245		Units
				Min	Max	Min	Max	
t _{PLH}	Propagation Delay Time Low to High Level Output	V _{CC} = 4.5V to 5.5V, R ₁ = R ₂ = 500Ω, C _L = 50 pF	A or B to B or A	3	10	3	10	ns
t _{PHL}	Propagation Delay Time High to Low Level Output		A or B to B or A	3	10	3	10	ns
t _{PZH}	Output Enable Time to High Level Output		\bar{G} to A or B	5	20	5	20	ns
t _{PZL}	Output Enable Time to Low Level Output		\bar{G} to A or B	5	20	5	20	ns
t _{PHZ}	Output Disable Time from High Level Output		\bar{G} to A or B	2	10	2	10	ns
t _{PLZ}	Output Disable Time from Low Level Output		\bar{G} to A or B	4	15	4	15	ns

Note 1: See Section 5 for test waveforms and output load.

ALS5245-1

Electrical Characteristics

over recommended free air temperature range

Symbol	Parameter	Test Conditions		74ALS5245-1			Units		
				Min	Typ	Max			
V _{IC}	Input Clamp Voltage	V _{CC} = Min, I _I = -18 mA				-1.5	V		
H _{YS}	Hysteresis (V _{T+} - V _{T-})	V _{CC} = Min		0.2	0.32		V		
V _{OH}	High Level Output Voltage	V _{CC} = 4.5V to 5.5V	I _{OH} = -0.4 mA	V _{CC} - 2			V		
		V _{CC} = Min	I _{OH} = -3 mA	2.4	3.2				
			I _{OH} = Max	2					
V _{OL}	Low Level Output Voltage	V _{CC} = Min	I _{OL} = 48 mA		0.45	0.53	V		
I _I	Input Current at Maximum Input Voltage	V _{CC} = Max					μA		
				I/O Ports, V _I = 5.5V		100			
				Control Inputs, V _I = 7V			100		
I _{IH}	High Level Input Current	V _{CC} = Max, V _I = 2.7V (Note 2)					20	μA	
I _{IL}	Low Level Input Current	V _{CC} = Max, V _I = 0.4V (Note 2)					-100	μA	
I _O	Output Drive Current	V _{CC} = Max, V _O = 2.25V		-30			-112	mA	
I _{CC}	Supply Current	V _{CC} = Max		Outputs High			30	45	mA
				Outputs Low			36	55	
				Outputs Disabled			38	58	

Note 2: For I/O ports, I_{IH} and I_{IL} parameters include the TRI-STATE output currents (I_{OZL} and I_{OZH}).

Switching Characteristics over recommended operating free air temperature range (Note 1)

Symbol	Parameter	Conditions	From (Input) To (Output)	74ALS5245-1		Units
				Min	Max	
t _{PLH}	Propagation Delay Time Low to High Level Output	V _{CC} = 4.5V to 5.5V, R ₁ = R ₂ = 500Ω, C _L = 50 pF	A or B to B or A	2	10	ns
t _{PHL}	Propagation Delay Time High to Low Level Output		A or B to B or A	3	10	ns
t _{PZH}	Output Enable Time to High Level Output		\bar{G} to A or B	4	20	ns
t _{PZL}	Output Enable Time to Low Level Output		\bar{G} to A or B	5	20	ns
t _{PHZ}	Output Disable Time from High Level Output		\bar{G} to A or B	1	10	ns
t _{PLZ}	Output Disable Time from Low Level Output		\bar{G} to A or B	3	15	ns

Note 1: See Section 5 for test waveforms and output load.

ALS Noise Characteristics

The setup of a noise characteristics measurement is critical to the accuracy and repeatability of the tests. The following is a brief description of the setup used to measure the noise characteristics of ALS.

Equipment:

Word Generator
Printed Circuit Board Test Fixture
Dual Trace Oscilloscope

Procedure:

1. Verify Test Fixture Loading: Standard Load 50 pF, 500Ω.
2. Deskew the word generator so that no two channels have greater than 150 ps skew between them. This requires that the oscilloscope be deskewed first. Swap out the channels that have more than 150 ps of skew until all channels being used are within 150 ps. It is important to deskew the word generator channels before testing. This will ensure that the outputs switch simultaneously.
3. Terminate all inputs and outputs to ensure proper loading of the outputs and that the input levels are at the correct voltage.
4. Set V_{CC} to 5.0V.
5. Set the word generator to toggle all but one output at a frequency of 1 MHz. Greater frequencies will increase DUT heating and affect the results of the measurement.

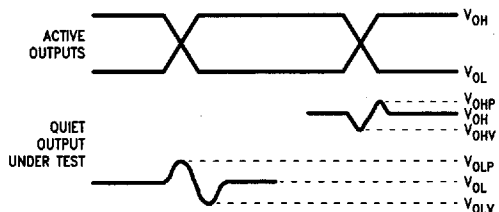

TL/F/9175-2

FIGURE 1. Quiet Output Noise Voltage Waveforms

Note A. V_{OHV} and V_{OHP} are measured with respect to V_{OH} reference. V_{OLV} and V_{OLP} are measured with respect to ground reference.

Note B. Input pulses have the following characteristics: $f = 1$ MHz, $t_r = 3$ ns, $t_f = 3$ ns, skew < 150 ps.

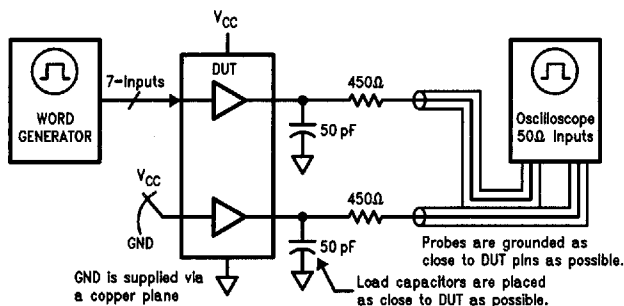

FIGURE 2. Simultaneous Switching Test Circuit

TL/F/9175-3

6. Set the word generator input levels at 0V LOW and 3V HIGH. Verify levels with a digital volt meter.

V_{OLP}/V_{OLV} and V_{OHP}/V_{OHV} :

- Determine the quiet output pin that demonstrates the greatest noise levels. The worst case pin will usually be the furthest from the ground pin. Monitor the output voltages using a 50Ω coaxial cable plugged into a standard SMB type connector on the test fixture. Do not use an active FET probe.
- Measure V_{OLP} and V_{OLV} on the quiet output during the HL transition. Measure V_{OHP} and V_{OHV} on the quiet output during the LH transition.
- Verify that the GND reference recorded on the oscilloscope has not drifted to ensure the accuracy and repeatability of the measurements.

V_{ILD} and V_{IHD} :

- Monitor one of the switching outputs using a 50Ω coaxial cable plugged into a standard SMB type connector on the test fixture. Do not use an active FET probe.
- First increase the input LOW voltage level, V_{IL} , until the output begins to oscillate. Oscillation is defined as noise on the output LOW level that exceeds V_{IL} limits, or on output HIGH levels that exceed V_{IH} limits. The input LOW voltage level at which oscillation occurs is defined as V_{ILD} .
- Next decrease the input HIGH voltage level on the word generator, V_{IH} until the output begins to oscillate. Oscillation is defined as noise on the output LOW level that exceeds V_{IL} limits, or on output HIGH levels that exceed V_{IH} limits. The input HIGH voltage level at which oscillation occurs is defined as V_{IHD} .
- Verify that the GND reference recorded on the oscilloscope has not drifted to ensure the accuracy and repeatability of the measurements.