

- 1 HOUSING MATERIAL: LIQUID CRYSTAL POLYMER
COLOR: NATURAL.
- 2 CONTACT MATERIAL: PHOSPHOR BRONZE
- 3 CONTACT FINISH:
UNDERPLATE (ENTIRE CONTACT):
0.00127 MIN NICKEL.
ON MATING SURFACES:
CONFORMS TO ALL TESTING SPECIFIED FOR TELCORDIA
UNCONTROLLED ENVIRONMENT.
ON LEADS
0.0005 MIN TIN-LEAD OVER UNDERPLATE.
LUBRICATION (ENTIRE CONTACT):
SURFACE CONDITIONER PER AMP SPEC 112-1002 AFTER PLATING.
- 4 PART MARKING LOCATED APPROXIMATELY AS SHOWN.
- 5 PART TO BE MARKED WITH DATE CODE ONLY.

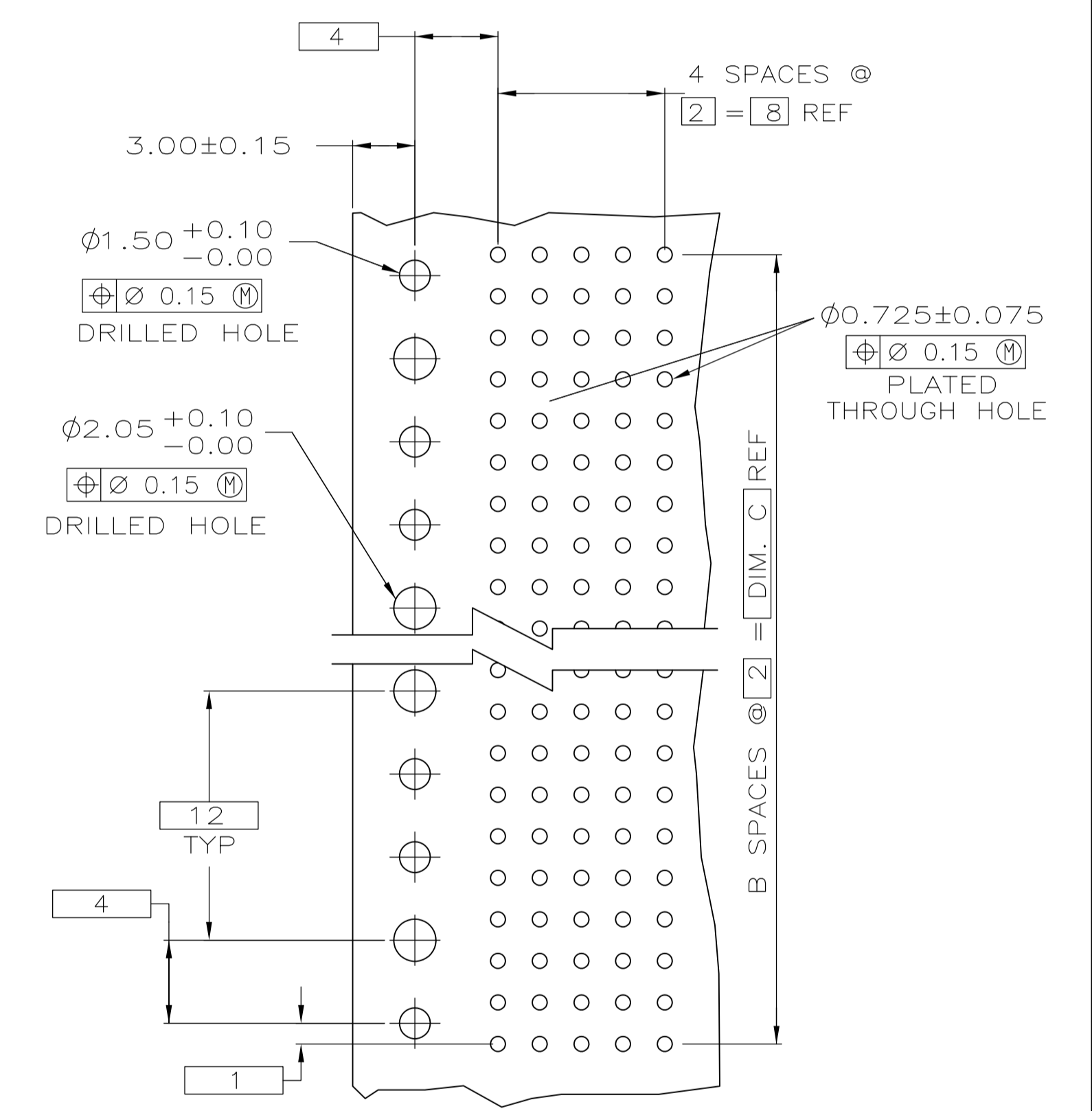

RECOMMENDED CIRCUIT PATTERN
PER IPC-D300 TYPE II, CLASS C
(COMPONENT SIDE)

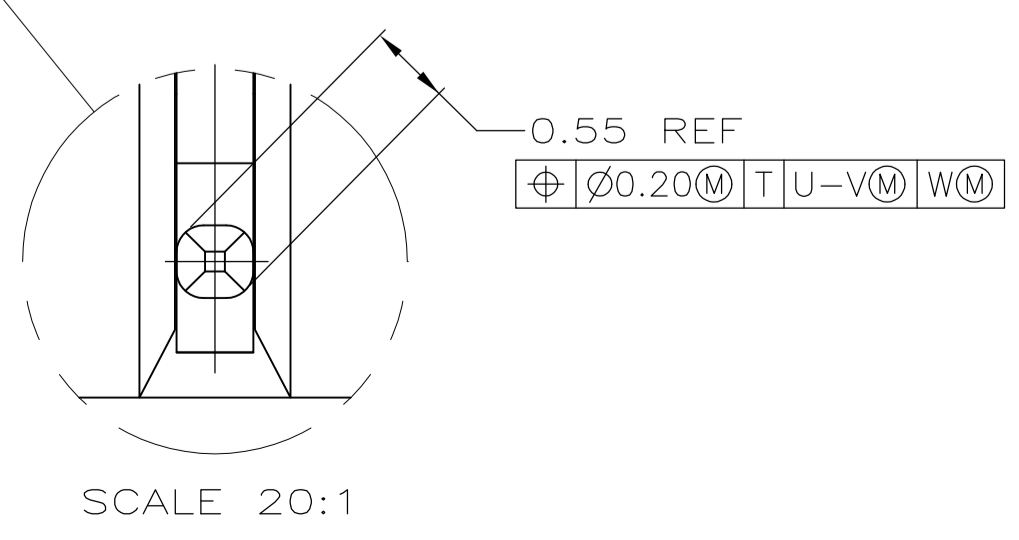

82	41	83.88	3	210	223524-7
70	35	71.88	3	180	223524-6
58	29	59.88	3	150	223524-5
46	23	47.88	3	120	223524-4
34	17	35.88	3	90	223524-3
22	11	23.88	3	60	223524-2
10	5	11.88	3	30	223524-1
C	B	A	FINISH	NO OF POSN	PART NUMBER

THIS DRAWING IS A CONTROLLED DOCUMENT.

DIMENSIONS:	TOLERANCES UNLESS OTHERWISE SPECIFIED:	0 PLC ± -	1 PLC ± -	2 PLC ± 0.13	3 PLC ± -	4 PLC ± -	ANGLES ± -
MATERIAL	FINISH	1	2	3			

DSK SCHRUM 08AUG99
 CJK SCHMID 08AUG99
 CJK SCHMID 08AUG99
 NAME: ASSEMBLY, PIN HEADER, RIGHT ANGLE, 5 ROW, Z-PACK 2mm FB, PRESS FIT LEADS
 SIZE: A1
 CAGE CODE: 00779
 DRAWING NO: 223524
 WEIGHT: --
 CUSTOMER DRAWING: --
 SCALE: 4:1
 SHEET: 1 OF 1
 REV: D2