

DS36C250 Controller Area Network (ISO/DIS 11898) Transceiver

General Description

The DS36C250 is a low power differential, bus transceiver designed to meet the requirements of the ISO/DIS 11898 Controller Area Network (CAN) Standard for multipoint data communication. The DS36C250 also meets the requirements of CAN V2.0..

The DS36C250 transceiver is composed of three major functional blocks: a transmitter with differential output, a differential input receiver and a voltage reference. Data to be transmitted over the CAN bus (CAN_H and CAN_L) is input to the DS36C250 on the TxD pin. Data received over the CAN bus is output via the RxD pin. The CAN bus data signal consists of a sequence of large and small amplitude differential voltages. A positive (or large) differential voltage represents the so-called "dominant" (or active) bit value. When the CAN bus voltage corresponds to the dominant bit, the CAN_H voltage is more positive than the CAN_L voltage. A zero differential voltage ($CAN_H = CAN_L \approx V_{CC}/2$) represents the "recessive" (or passive) bit value. Data signals applied to TxD or output from RxD are logically low-true. The signal polarity on CAN_H is inverted with respect to that of TxD or RxD. Additionally, each transceiver supplies current at a voltage equal to V_{REF} to maintain the CAN bus (CAN_H and CAN_L) at approximately $V_{CC}/2$ when the bus is in the recessive (passive) state.

The DS36C250 transmitter is designed to reduce EMI from the CAN bus. The CAN bus output rise and fall times are controlled by extracting current from the R_S pin. The control element can be as simple as a single resistor connected from the R_S pin to ground.

The DS36C250 is designed to resist fault conditions occurring on the CAN bus. The CAN bus I/O pins are designed to withstand overvoltages up to 25V. The receiver design allows operation over a common mode range of $-7V$ to $+12V$. The transmitter has thermal and current limiting in the output driver stage. Additionally, the device outputs withstand shorts to either V_{CC} or ground. The device is fully specified over the automotive temperature range ($-40^{\circ}C$ to $+125^{\circ}C$). The DS36C250 is form, fit and function compatible with other CAN transceivers while offering improved characteristics and performance.

Features

- Meets CAN V2.0B and ISO/DIS-11898 Standards
- Adjustable transmitter slew rate for low EMI/RFI
- Data rates up to 1M bit/s
- Low standby power
- Wide common mode range: $-7V$ to $+12V$
- CAN bus pins withstand up to 25V
- Automotive temperature range $-40^{\circ}C$ to $+125^{\circ}C$
- Industry standard function and pinout (Philips PCA82C250)
- Available in JEDEC SOIC-8 and mini-DIP packages

Product Application

- DS36C250 is suitable for all ISO/DIS 11898 and CAN V2.0B automotive and industrial applications.

Connection and Logic Diagram

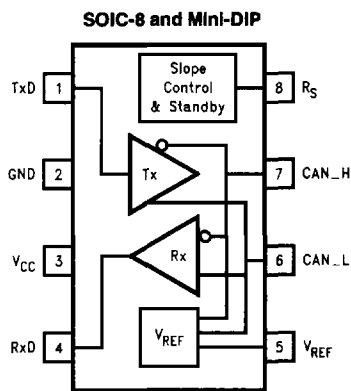

TL/F/12614-1

Pin Descriptions

Pin #	Name	Description
1	TxD	Transmitter Input, Inverted with Respect to CAN_H
2	GND	Circuit Ground (0V)
3	V_{CC}	Positive Power Supply Input ($+5V$, $\pm 10\%$)
4	RxD	Receiver Output, Inverted with Respect to CAN_H
5	V_{REF}	CAN Bus Reference Voltage Source $V_{CC}/2$
6	CAN_L	CAN Bus Low-Side Driver Output/ Receiver Input
7	CAN_H	CAN Bus High-Side Driver Output/ Receiver Input
8	R_S	CAN Bus Output Slope Control, Standby Mode Control

Truth Table (Z = transmitter output off or floating)

TRANSMITTER				
TxD	CAN_H	CAN_L	RxD	CAN BUS STATE
0	HIGH	LOW	0	Dominant
1	Z	Z	1	Recessive
unconnected	Z	Z	1	Recessive
RECEIVER				
1	HIGH	LOW	0	Dominant
1	Z	Z	1	Recessive

R_S Functions

FORCED CONDITION AT R_S	MODE	VOLTAGE OR CURRENT AT R_S
$V_{RS} > 0.75V_{CC}$	Standby	$ I_{RS} < 10 \mu A$
$-10 \mu A < I_{RS} < -200 \mu A$	Slope Control	$0.4V_{CC} < V_{RS} < 0.6V_{CC}$
$V_{RS} < 0.3V_{CC}$	High-Speed	$I_{RS} - 500 \mu A$

Absolute Maximum Ratings (Note 1)

If Military/Aerospace specified devices are required, please contact the National Semiconductor Sales Office/Distributors for availability and specifications.

Supply Voltage (V_{CC})	+12.0V
Input Voltage (TxD, R _S)	-0.5V to ($V_{CC} + 0.5V$)
Common Mode Voltage (CAN _H , CAN _L) (Note 8)	±20.0V
Input Voltage (CAN _H , CAN _L) (Note 8)	±25.0V
Output Voltage (Rx _D)	-0.5V to ($V_{CC} + 0.5V$)
Output Current (V_{REF})	±100 μ A
Maximum Package Power Dissipation @ +25°C	
M Package	TBD mW, derate TBD mW/°C above +25°C
N Package	TBD mW, derate TBD mW/°C above +25°C

Storage Temperature Range	-65°C to +150°C
Lead Temperature (Soldering 4 sec.)	+260°C
ESD Capability (Class 2 per MIL-STD-883C, test method 3015)	> 2 kV

Recommended Operating Conditions

	Min	Typ	Max	Units
Supply Voltage (V_{CC})	+4.5	+5.0	+5.5	V
CAN Bus Voltage (V_{CM})	-7.0		+12.0	V
Operating Free Air Temperature (T_A)	-40	25	125	°C

Electrical Characteristics

Over Supply Voltage and Operating Temperature Ranges, unless otherwise specified (Notes 2 and 3).

DEVICE DC POWER SUPPLY CHARACTERISTICS

Symbol	Parameter	Conditions	Reference	Min	Typ	Max	Units
I_{CC}	Power Supply Current	No Load, not Standby, $V_{RS} = 0V$, Tx _D = V _{IL}			200	500	μ A
I_{CDom}	Supply Current, Dominant	TxD = V _{IL} For R _L , see Note 9			40	70	mA
I_{CCRrec}	Supply Current, Recessive	TxD = V _{IH} , R _L = 60 Ω			12	18	mA
I_{CCStby}	Supply Current, Standby	TxD = V _{IH} , $V_{RS} = V_{IH}$				150	μ A

DRIVER DC CHARACTERISTICS

V_{IH}	High Level Input Voltage		TxD	2.0		V_{CC}	V
V_{IL}	Low Level Input Voltage		TxD	0.0		0.8	V
I_{IH}	High Level Input Current	$V_{IH} = V_{CC}$	TxD			2	μ A
I_{IL}	Low Level Input Current	$V_{IL} = 0V$	TxD			-2	μ A
$V_{CANDiff}$	Differential Output Voltage, $V_{CAN_H} - V_{CAN_L}$	Dominant, R _L = 60 Ω Recessive, R _L = 60 Ω	Figure 1	1.5 -500		3.0 50	V mV
$V_{CANHdom}$ $V_{CANLdom}$	Driver Output Voltage	Dominant, R _L = 60 Ω	CAN _H , Figure 2 CAN _L , Figure 2	2.75 0.5		4.5 2.25	V V
$V_{CANHrec}$ $V_{CANLrec}$	Driver Output Voltage	Recessive, R _L = 60 Ω	CAN _H , Figure 2 CAN _L , Figure 2	2.0 2.0		3.0 3.0	V V
V_{BAL}	Differential Output Voltage Balance	Dominant, R _L = 60 Ω	Figure 4		[TBD]		[mV]
I_{OSD}	Driver Output Short-Circuit Current	$V_{CAN_H} = -7$ to +12V V_{CAN_H} or L = 0V $V_{CAN_L} = -7V$ to +12V	Figure 3	0	-190 100	-250 +250	mA mA mA

RECEIVER DC CHARACTERISTICS

V_{OH}	High Level Output Voltage	$I_{OH} = -4$ mA	RxD, Figure 5	3.5	4.6		V
V_{OL}	Low Level Output Voltage	$I_{OL} = +4$ mA	RxD, Figure 5		0.3	0.5	V
I_{OSH}	Output Short Circuit Current	$V_O = GND$	RxD	-7	-35	-85	mA
I_{OSL}	Output Short Circuit Current	$V_O = V_{CC}$	RxD	7	35	85	mA
V_{Tdom}	Differential Input Dominant Threshold Voltage	$-7V \leq V_{CM} \leq +12V$	Figure 11	0.9		5.0	V
V_{Trec}	Differential Input Recessive Threshold Voltage	$-7V \leq V_{CM} \leq +12V$	Figure 11	-1.0		0.5	V
I_{IN}	Input Current (Note 4)	Other Input = $V_{CC}/2$, $V_{CC} = 0V$ or +5V \pm 10%	$V_I = +12V$ $V_I = -7$		TBD TBD	0.5 -0.4	mA mA

Electrical Characteristics (Continued)

Over Supply Voltage and Operating Temperature Ranges, unless otherwise specified (Notes 2 and 3).

Symbol	Parameter	Conditions	Reference	Min	Typ	Max	Units
RECEIVER DC CHARACTERISTICS (Continued)							
V_{HYS}	Hysteresis	$V_{CM} = 0V$	Note 5, Figure 13		150		mV
R_{IN}	Input Resistance	$-7V \leq V_{CM} \leq +12V$		TBD	68		k Ω
R_{INdiff}	Differential Input Resistance				TBD		k Ω
RECEIVER AC CHARACTERISTICS							
C_{IN}	Input Capacitance, TxD				TBD		pF
$C_{IN(CAN)}$	Input Capacitance, CAN_H or CAN_L				TBD		pF
C_{INdiff}	Differential Input Capacitance, CAN_H to CAN_L				TBD		pF
REFERENCE OUTPUT DC CHARACTERISTICS							
V_{REF}	Reference Output Voltage	$I_L = \pm 50 \mu A$		$0.45V_{CC}$	$0.5V_{CC}$	$0.55V_{CC}$	V
I_{REF}	Reference Output Current					± 100	μA
SLOPE CONTROL/STANDBY DC CHARACTERISTICS							
V_{RS}	Slope Control Input Voltage for F_{max}					$0.3 V_{CC}$	V
I_{RS}	Slope Control Input Current for F_{max}	$V_{RS} = 0V$				-500	μA
$V_{standby}$	Slope Control Input Voltage for Standby Mode			$0.75 V_{CC}$			V
I_{slope}	Slope Control Mode Current Range			-10		-200	μA
V_{slope}	Slope Control Mode Voltage Range			$0.4 V_{CC}$		$0.6 V_{CC}$	V

Switching Characteristics

Over Supply Voltage and Operating Temperature Ranges, unless otherwise specified (Note 3).

Symbol	Parameter	Conditions	Reference	Min	Typ	Max	Units
F_{MAX}	Maximum Operating Frequency	$I_{RS} = \max.$			1		MHz
t_{bit}	Minimum Bit Time	$I_{RS} = \max.$			1		μs
DRIVER SWITCHING CHARACTERISTICS							
t_{offTxD}	Differential Propagation Delay Dom. to Rec.	$R_L = 60\Omega, C_L = 100\text{ pF}$	Figures 6 & 9		40	80	ns
t_{onTxD}	Differential Propagation Delay Rec. to Dom.	$V_{RS} = 0V$	Figures 6 & 9		TBD	50	ns
t_{SKD}	Differential Skew $ t_{PHLD} - t_{PLHD} $	$V_{RS} = 0V$	Figure 10, (Note 6)		TBD	TBD	ns
t_r	Rise Time	$V_{RS} = 0V$ or	Figure 12		TBD		ns
t_f	Fall Time	$I_{RS} < -500\text{ }\mu A$			TBD		ns
t_r	Rise Time	$I_{RS} = -100\text{ }\mu A$	Figure 12		TBD		ns
t_f	Fall Time				TBD		ns
t_r	Rise Time	$I_{RS} = -20\text{ }\mu A$	Figure 12		TBD		ns
t_f	Fall Time				TBD		ns
RECEIVER SWITCHING CHARACTERISTICS							
t_{offRxD}	Delay TxD = V_{IH} to RxD = V_{OH}	$I_{RS} = \max$	Figures 7 & 9		TBD	160	ns
t_{onRxD}	Delay TxD = V_{IL} to RxD = V_{OL}	$I_{RS} = \max$	Figures 7 & 9		TBD	130	ns
t_{PHL}	Propagation Delay $V_{CANDiff}$ Dominant to RxD = V_{OL}	$C_L = 15\text{ pF}$	Figures 7 & 9			80	ns
t_{PLH}	Propagation Delay $V_{CANDiff}$ Recessive to RxD = V_{OH}	$C_L = 15\text{ pF}$	Figures 7 & 9			80	ns
t_{SKR}	Skew, $ t_{PHL} - t_{PLH} $		Figure 8, (Note 6)		10	TBD	ns
t_{WAKE}	Wake-Up from Standby	via Pin 8				20	μs
t_{dRxDL}	CAN Bus Dominant to RxD = V_{OL}	Standby Mode $V_{RS} = V_{IH}$				3	μs

Note 1: "Absolute Maximum Ratings" are those parameter values beyond which the life and operation of the device cannot be guaranteed. The stating herein of these maximums shall not be construed to mean that the device can or should be operated at or beyond these values. The table of "Electrical Characteristics" specifies acceptable device operating conditions. All voltages are measured with respect to pin 2 (GND).

Note 2: Positive current is defined as flowing into device pins. Negative current is defined as flowing out of device pins. All voltages are referenced to ground (equal to zero volts) with the exception of $V_{CANDiff}$, V_{BAL} , V_{Tdom} , V_{Trec} , V_{HYS} .

Note 3: Typical values are stated for: $V_{CC} = +5.0V$ and $T_A = +25^\circ C$.

Note 4: I_{IN} includes both the receiver input current and driver recessive-state leakage current.

Note 5: Hysteresis is defined as $V_{HYS} = V_{TH} - V_{TL}$. (Figure 13).

Note 6: Signal skews are defined as the largest magnitude difference between and without regard to the sequence of the specified edges.

Note 7: C_L includes probe and jig capacitances.

Note 8: The voltage applied between the CAN_H and CAN_L pins may not exceed $|25V\text{ D.C.}|$.

Note 9: $I_{CCdem(typ)}$ is measured using the 60Ω CAN bus termination. $I_{CCdem(max)}$ is measured using a 45Ω load which represents the parallel equivalent of 128 inputs (typical I_{IN}) and the CAN bus termination.

Parameter Measurement Information

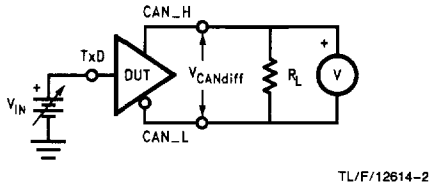

FIGURE 1. Driver $V_{CANDiff}$ Dominant and Recessive

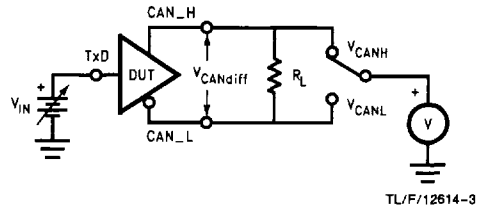

FIGURE 2. Driver V_{CANH} and V_{CANL} Dominant and Recessive

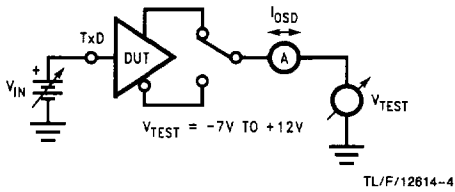

FIGURE 3. Driver I_{OSD}

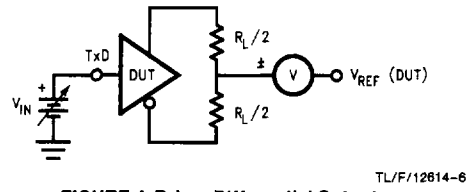

FIGURE 4. Driver Differential Output Voltage Balance (V_{BAL})

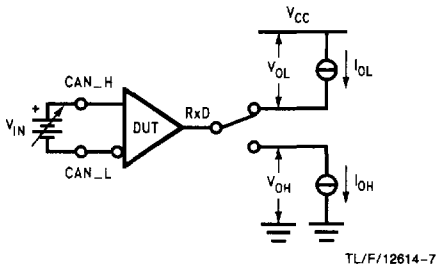

FIGURE 5. Receiver V_{OL}/I_{OL} and V_{OH}/I_{OH}

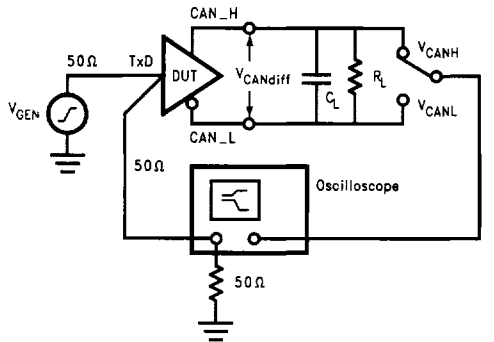

FIGURE 6. Driver Differential Propagation Delay Test Circuit

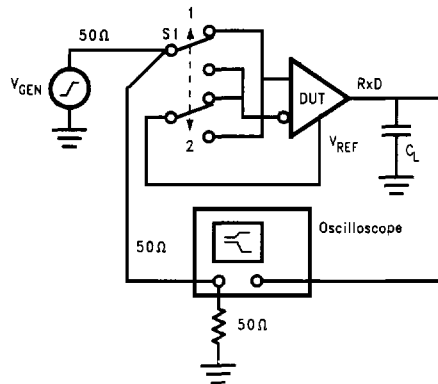

FIGURE 7. Receiver Differential Propagation Delay Test Circuit

Parameter Measurement Information (Continued)

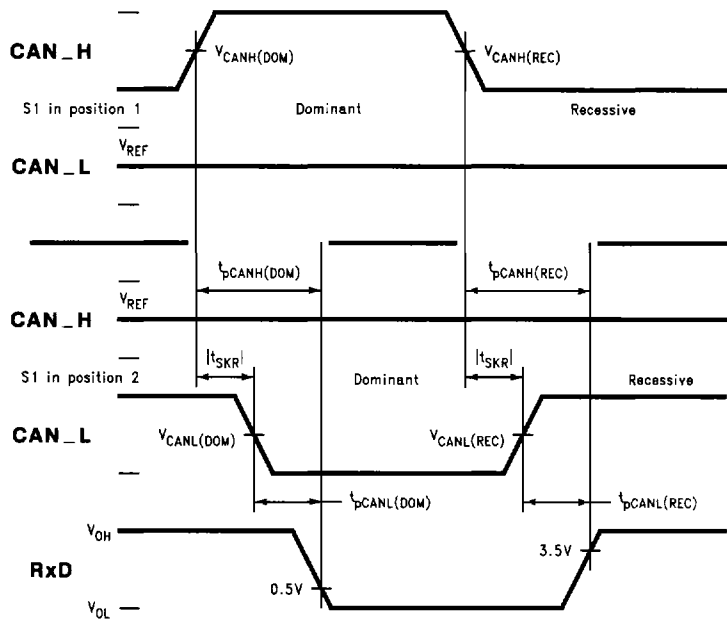

FIGURE 8. Receiver Skew Timing

TL/F/12614-10

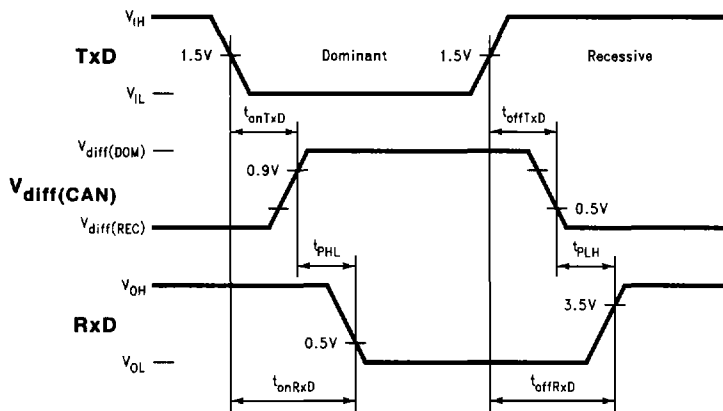

FIGURE 9. Propagation Delays

TL/F/12614-9

Parameter Measurement Information (Continued)

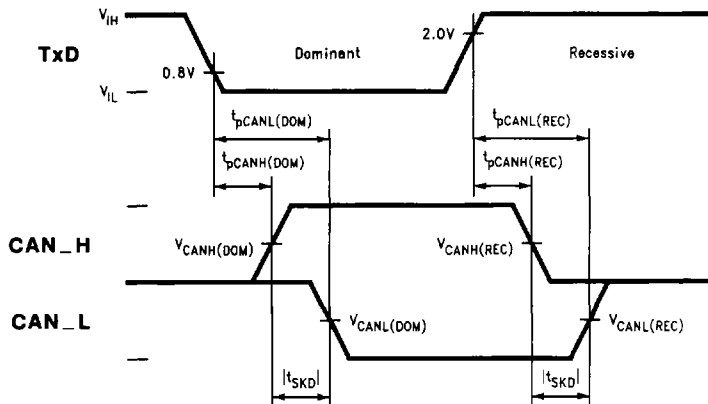

FIGURE 10. Driver Skew Timing

TL/F/12614-11

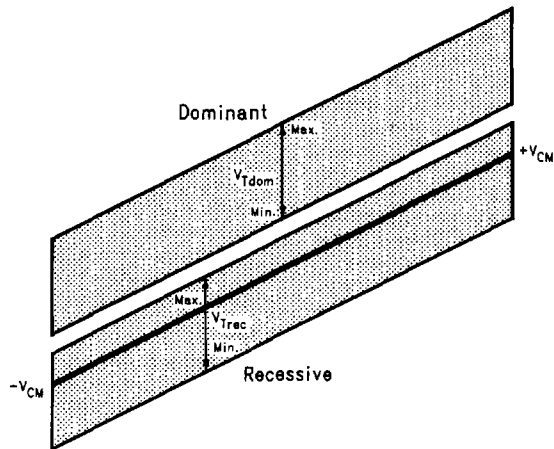

FIGURE 11. Differential Input Threshold

TL/F/12614-12

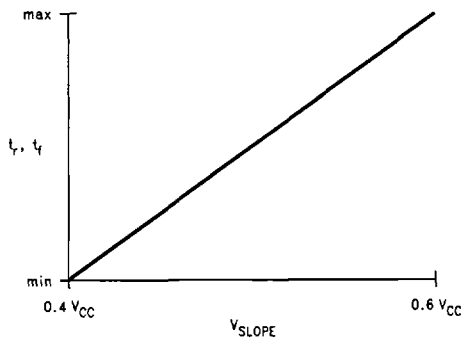

FIGURE 12. Driver Slew Rate vs R_p Pin Control Voltage

TL/F/12614-14

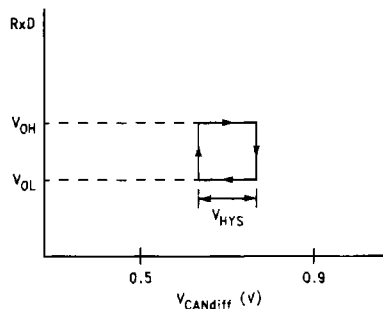
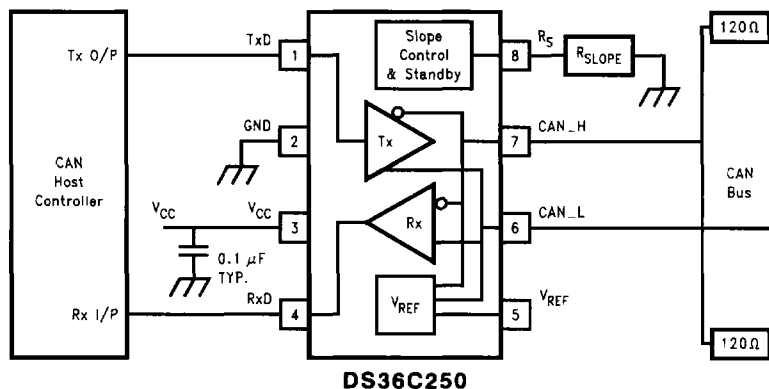

FIGURE 13. Hysteresis

TL/F/12614-15

Applications Information

Typical Application with Host Control



DS36C250

TL/F/12814-13

CAN BUS OUTPUT SLEW RATE CONTROL

The slew-rate of the CAN bus outputs is controlled by the amount of current flowing in pin 8, the R_S pin. Grounding pin 8, called high-speed mode, defeats the slew rate control circuitry and causes the CAN bus outputs to slew at their maximum rates. For lower speed operation and slope control, current is sunk from pin 8. This can be done using a resistor or other equivalent means. The output signal slopes will be proportional to the amount of current extracted from pin 8. When the current flowing in pin 8 is reduced to zero, the part enters the low-current, standby mode. In standby, the transmitter is switched off and the receiver placed in a powered-down mode. If dominant bits are detected on the CAN bus while the device is in standby mode, Rx D will go to a low logic level. The host should then re-activate the transceiver to a normal operating mode by increasing current flow out of pin 8. Messages received while in standby mode will be lost because of the slowed response of the receiver and should be re-transmitted after the receiver is in a normal operating mode.

CAN BUS OUTPUT THERMAL, VOLTAGE AND CURRENT LIMITING

The DS36C250 incorporates thermal limiting and over-current/voltage protection in the CAN bus outputs. Thermal limiting in the transmitter outputs restricts the maximum junction temperature to less than 150°C. Receiver operation is maintained during transmitter thermal limiting. Current and voltage limiting are incorporated in the design to protect against fault conditions which may occur on the CAN bus

outputs such as shorts to large positive and negative battery voltages, shorts to ground, electrical transients, load dump, etc.

CAN BUS OUTPUT RECESSIVE-MODE REFERENCE POTENTIAL

The DS36C250 sources current to the CAN bus lines at a reference potential approximately equal to $V_{CC}/2$ when it is in the recessive mode (and not in the standby mode). The amount of current supplied by one or more devices connected to a properly CAN bus allows the connection of a maximum of 128 devices to the network. *Note: It should be understood that the amount of current contributed to the network by any one of N devices connected to the network will be approximately I/N ; where I is the current source capability of a single device into the terminated network.*

EMI/RFI

The design of the transmitter and its output signals CAN_H and CAN_L minimizes production of both EMI/RFI and common-mode noise signals.

NETWORK SIZE LIMITS

The maximum number of network nodes in a normal CAN automotive application is 30. The DS36C250 is designed to have equivalent performance in networks having 128 nodes. In order to achieve this, particular attention has been given to parameters affecting the equivalent load that the device presents to the bus. The critical parameters include: transmitter output leakage current, receiver input resistance (and impedance), reference current source impedance, and pin reactances.