

General Description

The MA2502W is the highest performance trench N-ch MOSFETs with extreme high cell density, which provide excellent RDSON and gate charge for most of the small power switching and load switch applications.

The MA2502W meet the RoHS and Green Product requirement with full function reliability approved.

Features

- Advanced high cell density Trench technology
- Super Low Gate Charge
- Excellent Cdv/dt effect decline
- Green Device Available

Absolute Maximum Ratings

Symbol	Parameter	Rating	Units
V_{DS}	Drain-Source Voltage	20	V
V_{GS}	Gate-Source Voltage	± 12	V
$I_D@T_A=25$	Continuous Drain Current, $V_{GS} @ 4.5V^1$	5.8	A
$I_D@T_A=70$	Continuous Drain Current, $V_{GS} @ 4.5V^1$	4.6	A
I_{DM}	Pulsed Drain Current ²	24	A
$P_D@T_A=25$	Total Power Dissipation ³	1.1	W
T_{STG}	Storage Temperature Range	-55 to 150	
T_J	Operating Junction Temperature Range	-55 to 150	

Thermal Data

Symbol	Parameter	Typ.	Max.	Unit
$R_{\theta JA}$	Thermal Resistance Junction-ambient ¹	---	110	/W
$R_{\theta JC}$	Thermal Resistance Junction-Case ¹	---	70	/W

Product Summary



BVDSS	RDSON	ID
20V	22mΩ	5.8A

Applications

- Power management in portable and battery operated products
- DC-DC Power System
- Load Switch

TSSOP8 Pin Configuration

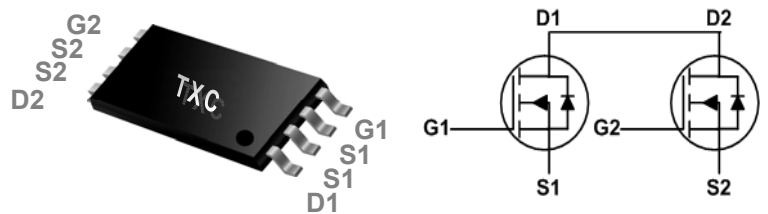

Electrical Characteristics ($T_J=25$, unless otherwise noted)

Symbol	Parameter	Conditions	Min.	Typ.	Max.	Unit
BV_{DSS}	Drain-Source Breakdown Voltage	$V_{GS}=0V, I_D=250\mu A$	20	---	---	V
BV_{DSS}/T_J	BVDSS Temperature Coefficient	Reference to 25 , $I_D=1mA$	---	0.024	---	V/
$R_{DS(ON)}$	Static Drain-Source On-Resistance ²	$V_{GS}=4.5V, I_D=5A$	---	17	22	m Ω
		$V_{GS}=2.5V, I_D=4A$	---	21	28	
$V_{GS(th)}$	Gate Threshold Voltage	$V_{GS}=V_{DS}, I_D=250\mu A$	0.5	0.8	1.2	V
$V_{GS(th)}$	$V_{GS(th)}$ Temperature Coefficient		---	-3.58	---	mV/
I_{DSS}	Drain-Source Leakage Current	$V_{DS}=16V, V_{GS}=0V, T_J=25$	---	---	1	μA
		$V_{DS}=16V, V_{GS}=0V, T_J=55$	---	---	5	
I_{GSS}	Gate-Source Leakage Current	$V_{GS}=\pm 12V, V_{DS}=0V$	---	---	± 100	nA
gfs	Forward Transconductance	$V_{DS}=5V, I_D=5A$	---	25.4	---	S
R_g	Gate Resistance	$V_{DS}=0V, V_{GS}=0V, f=1MHz$	---	1.5	3	Ω
Q_g	Total Gate Charge (4.5V)	$V_{DS}=15V, V_{GS}=4.5V, I_D=5A$	---	11.3	15.8	nC
Q_{gs}	Gate-Source Charge		---	1.59	2.2	
Q_{gd}	Gate-Drain Charge		---	2.86	4.0	
$T_{d(on)}$	Turn-On Delay Time	$V_{DD}=10V, V_{GS}=4.5V, R_G=3.3\Omega$ $I_D=5A$	---	5	10.0	ns
T_r	Rise Time		---	53.4	96	
$T_{d(off)}$	Turn-Off Delay Time		---	27	54	
T_f	Fall Time		---	8.8	17.6	
C_{iss}	Input Capacitance	$V_{DS}=15V, V_{GS}=0V, f=1MHz$	---	865	1211	pF
C_{oss}	Output Capacitance		---	86	120	
C_{riss}	Reverse Transfer Capacitance		---	72	101	

Diode Characteristics

Symbol	Parameter	Conditions	Min.	Typ.	Max.	Unit
I_S	Continuous Source Current ^{1,4}	$V_G=V_D=0V, \text{Force Current}$	---	---	5.8	A
I_{SM}	Pulsed Source Current ^{2,4}		---	---	24	A
V_{SD}	Diode Forward Voltage ²	$V_{GS}=0V, I_S=1A, T_J=25$	---	---	1.2	V
t_{rr}	Reverse Recovery Time	$I_F=5A, di/dt=100A/\mu s, T_J=25$	---	8.3	---	nS
Q_{rr}	Reverse Recovery Charge		---	2.4	---	nC

Note :

- 1.The data tested by surface mounted on a 1 inch² FR-4 board with 20Z copper.
- 2.The data tested by pulsed , pulse width $\leq 300\mu s$, duty cycle $\leq 2\%$
- 3.The power dissipation is limited by 150 junction temperature
- 4.The data is theoretically the same as I_D and I_{DM} , in real applications , should be limited by total power dissipation.

Typical Characteristics

Dual N-Ch 20V Fast Switching MOSFETs

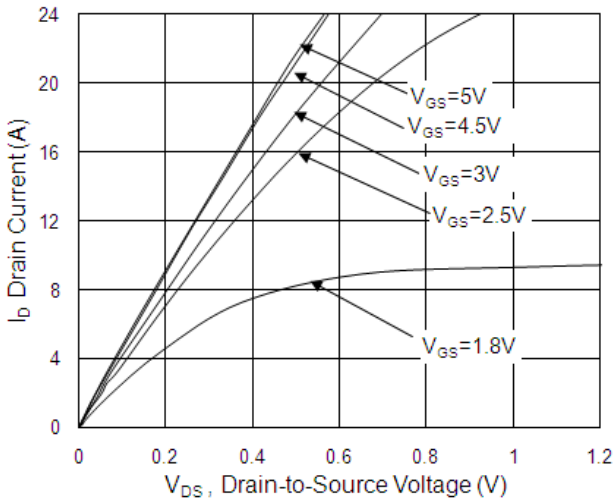

Fig.1 Typical Output Characteristics

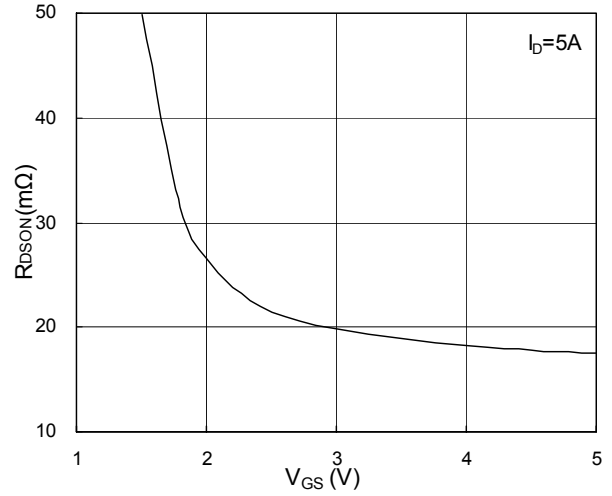

Fig.2 On-Resistance vs. Gate-Source

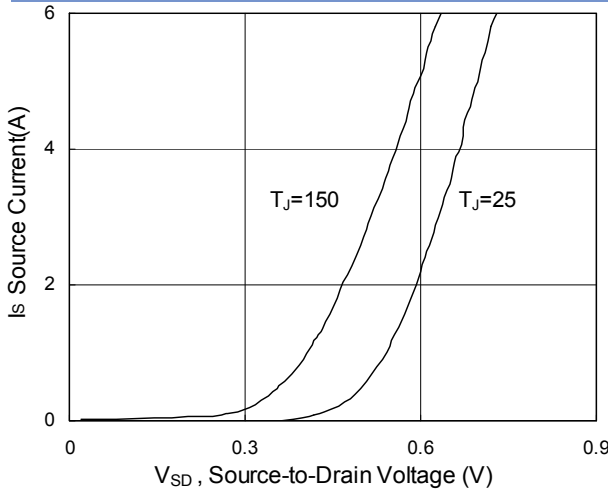

Fig.3 Forward Characteristics Of Reverse

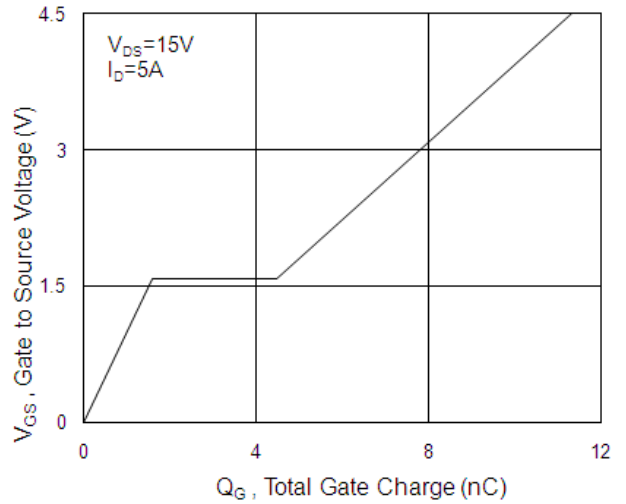

Fig.4 Gate-Charge Characteristics

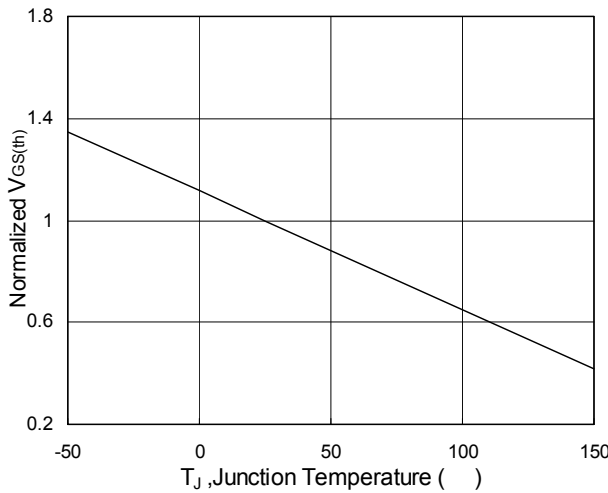

Fig.5 $V_{GS(th)}$ vs. T_J

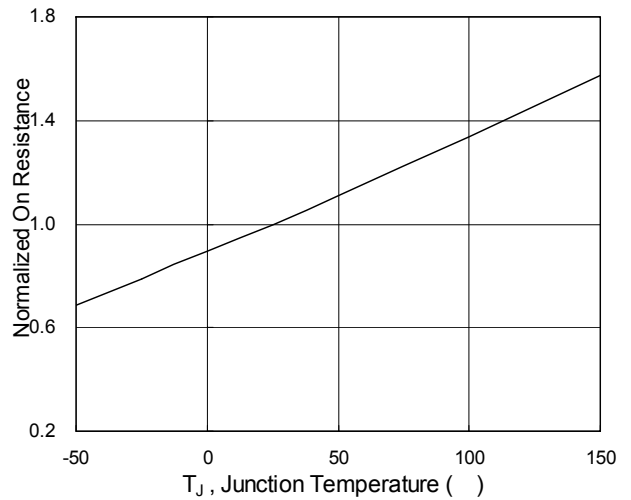

Fig.6 Normalized $R_{DS(on)}$ vs. T_J

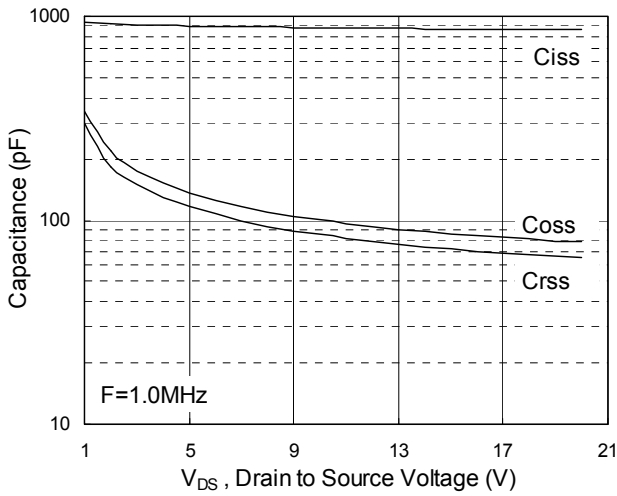

Fig.7 Capacitance

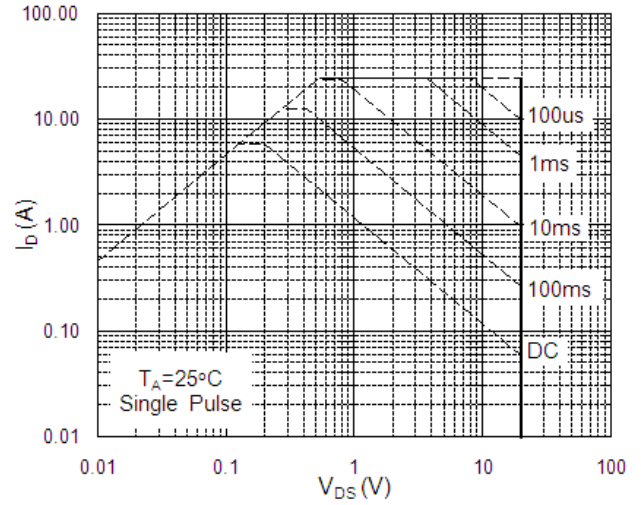

Fig.8 Safe Operating Area

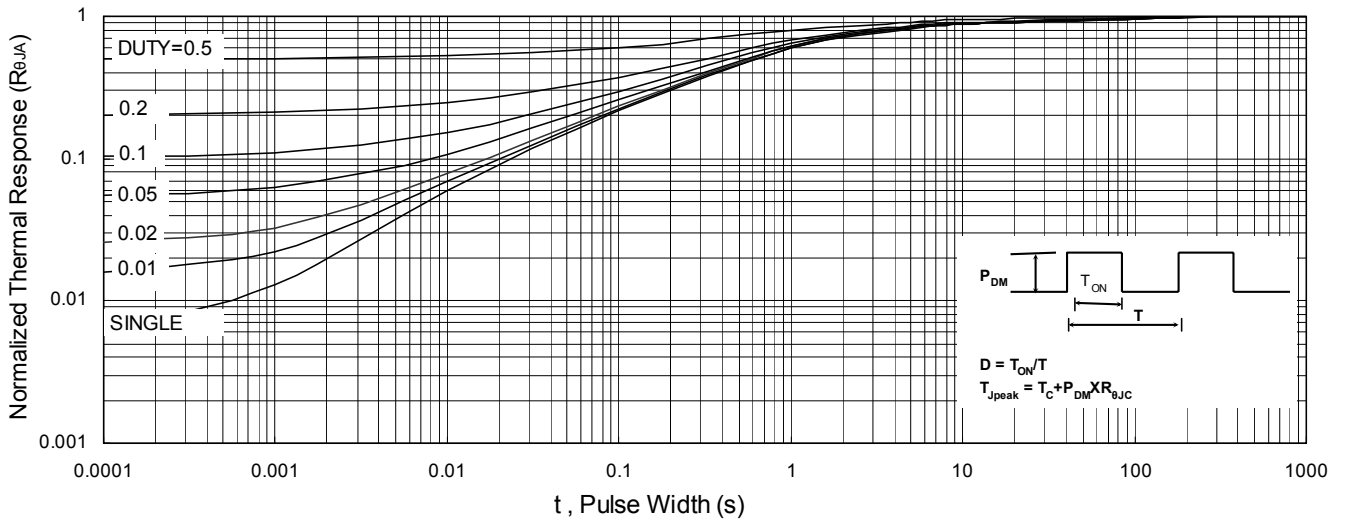

Fig.9 Normalized Maximum Transient Thermal Impedance

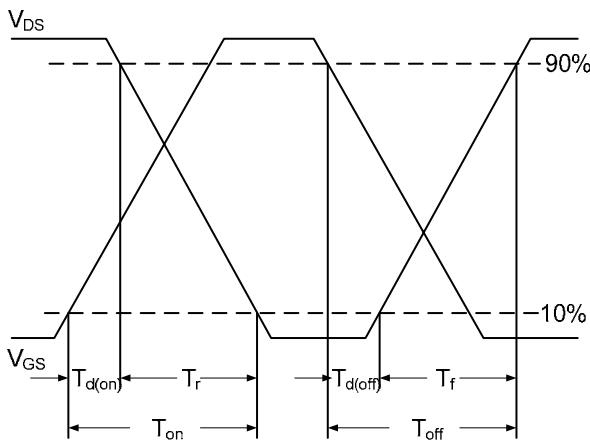

Fig.10 Switching Time Waveform

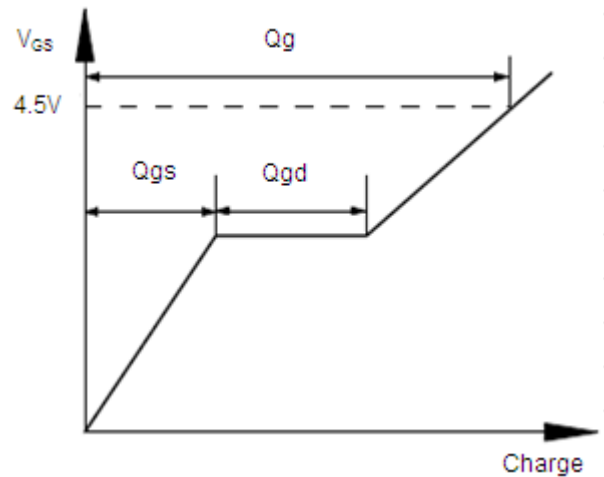
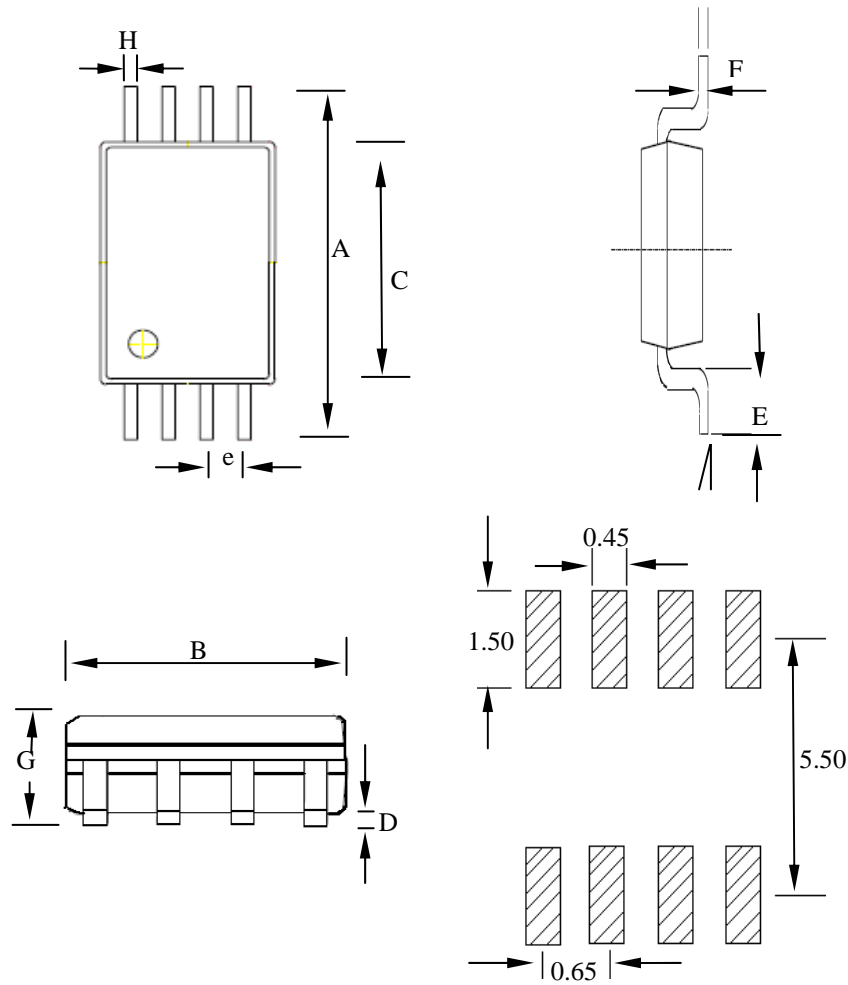
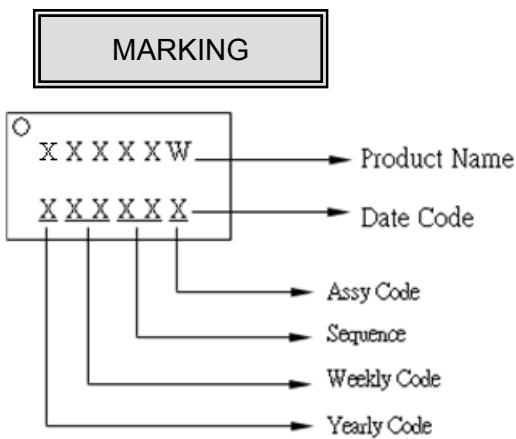

Fig.11 Gate Charge Waveform

Dual N-Ch 20V Fast Switching MOSFETs



LAND PATTERN RECOMMENDATION



SYMBOLS	MILLIMETERS			INCHES		
	MIN	NOM	MAX	MIN	NOM	MAX
A	6.30	6.40	6.50	0.248	0.252	0.256
B	2.90	--	3.10	0.114	--	0.122
C	4.30	--	4.50	0.169	--	0.177
D	0.05	--	0.15	0.002	--	0.006
E	0.45	--	0.75	0.018	--	0.030
F	0.09	--	0.20	0.004	--	0.008
G	1.10	--	1.20	0.043	--	0.047
e	--	0.65	--	--	0.026	--
H	0.19	--	0.30	0.007	--	0.012
θ	0°	--	8°	0°	--	8°

Note:

1. PACKAGE BODY SIZES EXCLUDE MOLD FLASH AND GATE BURRS.
2. CONTROLLING DIMENSION IS MILLIMETER CONVERTED INCH DIMENSIONS ARE NOT NECESSARILY EXACTLY.

Tape & Reel 繞卷及裝箱方式 - TSSOP-8

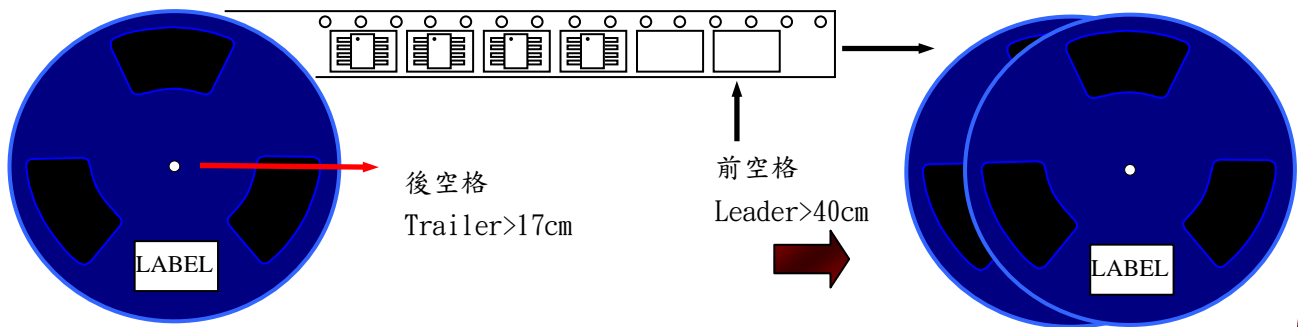

產品正印及方向 - (辨識點為左上時, Tape 圓孔在上方)

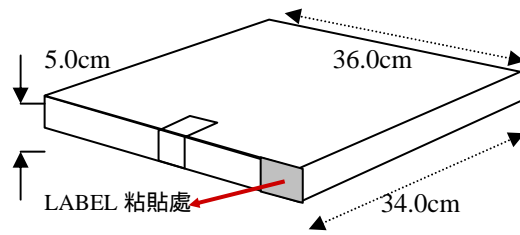
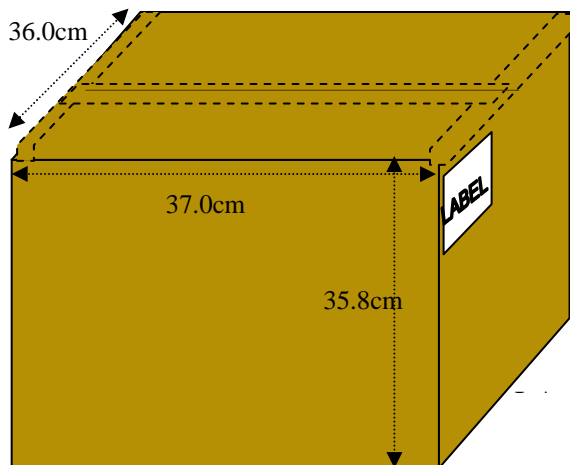
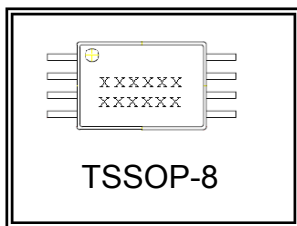

封裝形態 PKG TYPE	一卷數量 Immediate Quantity	中箱數量 Intermediate Quantity	外箱裝置/數量 Carton Quantity
SOP/PSOP-8	3000pcs	6000pcs	30K
TSSOP-8	Reel (13")	Box(2 reels)	Carton(5 Box)