

# Single-mode 155Mbps 2X10 SFF Transceiver

## Features

- LC duplex receptacle
- Standard 2 x 10 footprint
- 1310nm or 1550nm laser transmitter with automatic power control
- Laser bias and power monitor
- AC or DC coupled LVPECL/PECL compatible data input and output
- Transmitter disable input
- PECL or TTL signal detect output
- Single 3.3V or 5V power supply



## Specifications

Parameter		Symbol	Min.	Typ.	Max.	Unit
<b>Transmitter</b>						
Data Rate (NRZ)		B	10	155	250	Mb/s
Optical Output Power (avg.) <sup>(1)(5)</sup>						
-1		P <sub>o</sub>	-12	-	-6	dBm
-2		P <sub>o</sub>	-5	-	0	dBm
-3		P <sub>o</sub>	-3	-	+2	dBm
Extinction Ratio <sup>(2)(3)(4)</sup>		ER	10	-	-	dB
Optical Wavelength						
1310nm FP LD <sup>(2)(3)</sup>		$\lambda_c$	1270	1310	1360	nm
1550nm DFB LD <sup>(4)</sup>		$\lambda_c$	1530	1550	1570	nm
Spectral Width						
1310nm FP LD (RMS) <sup>(2)(3)</sup>		$\Delta\lambda$	-	-	2.5	nm
1550nm DFB LD (-20dB) <sup>(4)</sup>		$\Delta\lambda$	-	-	1	nm
Side Mode Suppression Ratio						
1550nm DFB LD <sup>(4)</sup>		SMSR	30	-	-	dB
Output Rise Time (10-90%)		t <sub>r</sub>	-	0.4	1	ns
Output Fall Time (10-90%)		t <sub>f</sub>	-	1.0	1.5	ns
Data Input <sup>(9)</sup>	DC Coupled	V <sub>IL</sub> V <sub>IH</sub>	V <sub>CC</sub> -1.810 V <sub>CC</sub> -1.165	- -	V <sub>CC</sub> -1.475 V <sub>CC</sub> -0.880	V V
	AC Coupled (Differential)	V <sub>I</sub>	0.25	-	1.6	V
Tx Disable Input		V <sub>DIL</sub> V <sub>DIH</sub>	0 2	- -	0.8 V <sub>CC</sub>	V V
Laser Bias Monitor (BM) <sup>(10)</sup>		BM	-	0.1	-	mA/mV
Laser Power Monitor (TPM) <sup>(10)</sup>		TPM	-	5	-	μA/mV
Supply Voltage		V <sub>CC</sub>	3.10 4.75	3.3 5.0	3.50 5.25	V V
Supply Current		I <sub>CC</sub>	-	-	110	mA

## Single-mode 155Mbps 2X10 SFF Transceiver

Parameter	Symbol	Min.	Typ.	Max.	Unit	
<b>Receiver</b>						
Data Rate (NRZ)	B	10	155	250	Mb/s	
Optical Input Sensitivity (avg.) <sup>(1) (2) (3) (4) (7)</sup>	$P_{IN}$	-	-38	-34	dBm	
Saturation	$P_{SAT}$	-3	-	-	dBm	
Optical Wavelength	$\lambda$	1100	-	1600	nm	
Output Rise Time (10-90%)	$t_r$	-	1.5	2.5	ns	
Output Fall Time (10-90%)	$t_f$	-	1.5	2.5	ns	
Data Output <sup>(9)</sup>	DC Coupled	$V_{OL}$ $V_{OH}$	$V_{CC} - 1.840$ $V_{CC} - 1.045$	- -	$V_{CC} - 1.62$ $V_{CC} - 0.88$	V V
	AC Coupled (Differential)	$V_I$	0.6	-	1.8	V
Signal Detect Asserted (avg)	$P_A$	-	-	-34	dBm	
Signal Detect Deasserted (avg)	$P_D$	-48	-	-	dBm	
Hysteresis	$P_{HYS}$	-	2	-	dB	
Supply Voltage	$V_{CC}$	3.10 4.75	3.3 5.0	3.50 5.25	V V	
Supply Current	$I_{CC}$	-	-	100	mA	

Notes :

- (1) With 0.275 NA, 9/125 $\mu$ m fiber.
- (2) Compliant to GR-253-CORE SONET OC-3 IR-1 and ITU-T G.957 STM-1 S-1.1.
- (3) Compliant to GR-253-CORE SONET OC-3 LR-1 and ITU-T G.957 STM-1 L-1.1.
- (4) Compliant to GR-253-CORE SONET OC-3 LR-2 and ITU-T G.957 STM-1 L-1.2.
- (5) Class 1 eye safe per FDA and IEC.
- (6) Transmitter eye mask diagram is compliant to ITU-T G.957 Eye Diagram.
- (7)  $2^{23} - 1$  PRBS, BER=  $10^{-10}$ .
- (8) The transmitter output should not be viewed directly.
- (9) Compatible with PECL and LVPECL logic levels.
- (10) The figure below shows the laser bias monitor and power monitor equivalent circuit.

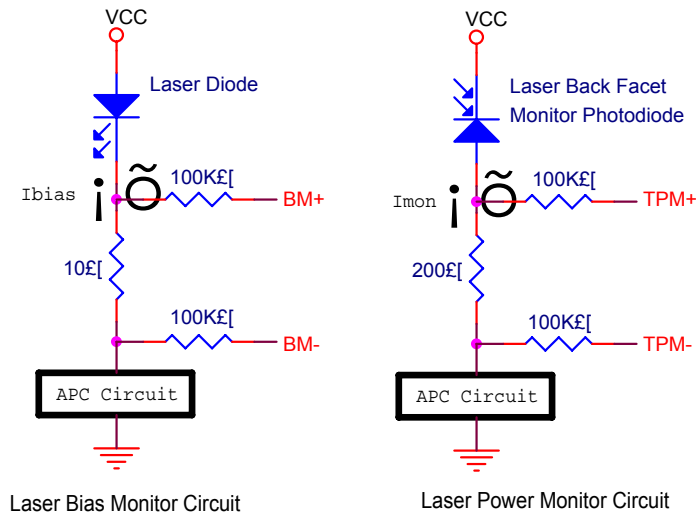

## Single-mode 155Mbps 2X10 SFF Transceiver

### Absolute Maximum Ratings

Parameter		Min.	Max.	Unit
Operating Temperature	-1	0	70	°C
	-2	-40	85	°C
Storage Temperature		-40	100	°C
Lead Soldering Limits		-	240/10	°C /sec
Supply Voltage	5V	-0.2	7	V
	3.3V	-0.2	4	V

# Single-mode 155Mbps 2X10 SFF Transceiver

## Ordering Information

T R □ □ S M 1 - □ □ L C □ K R 1 □ □

**Operating Temperature Range :**

1 : 0 ~ 70°C

2 : -40 ~ 85°C

**Data Coupling & SD Output Level :**

Symbol	Tx Coupling	Rx Coupling	SD
C	AC	DC	PECL
D	AC	DC	TTL
E	AC	AC	PECL
F	AC	AC	TTL
G	DC	DC	PECL
H	DC	DC	TTL
I	DC	AC	PECL
J	DC	AC	TTL

**Supply Voltage :**

5 : 5V

3 : 3.3V

**Laser Type :**

L : FP LD

F : DFB LD

**Tx Output Power Grade :** (refer to Specifications)

1 : -1

2 : -2

**Wavelength :**

13 : 1310nm

15 : 1550nm

Part Number	Laser Type	Power Budget <sup>(1)</sup>	Recommended Maximum Reach <sup>(2)</sup>	Compliant to SONET OC-3 / SDH STM-1 <sup>(4)</sup>
TR13SM1-1LLC□ KR1□ □	1310nm, FP	22dB	54Km	IR-1 / S-1.1
TR13SM1-2LLC□ KR1□ □	1310nm, FP	29dB	74Km	LR-1 / L-1.1
TR15SM1-2FLC□ KR1□ □	1550nm, DFB	29dB	104Km	LR-2 / L-1.2

**Notes :**

- (1) Power Budget (min.) = TX Output Power (min.) - RX Sensitivity (min.)
- (2) Assuming connector loss 3dB; 1310nm fiber attenuation coefficient 0.35dB/Km; 1550nm fiber attenuation coefficient 0.25dB/Km.
- (3) The maximum reach value is recommended, not guaranteed. The exact transmission distance depends on fiber loss, connector loss and system penalty.
- (4) SONET/SDH standard specification is defined in GR-253-CORE/ITU-T G.957.

# Single-mode 155Mbps 2X10 SFF Transceiver

## Outline Drawing

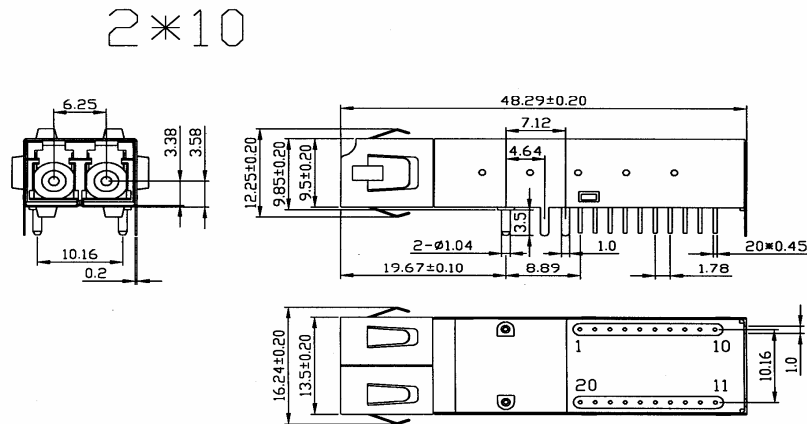

UNIT : mm

### Pinout Description

Pin No.	Symbol	Description
1	V <sub>PD</sub>	Receiver PD Bias Supply
2	V <sub>EER</sub>	Receiver Ground
3	V <sub>EER</sub>	Receiver Ground
4	NC	No Connection
5	NC	No Connection
6	V <sub>EER</sub>	Receiver Ground
7	V <sub>CCR</sub>	Receiver Power Supply
8	SD	Receiver Signal Detect
9	RD-	Receiver Data Out (Inverted)
10	RD+	Receiver Data Out
11	V <sub>CCT</sub>	Transmitter Power Supply
12	V <sub>EET</sub>	Transmitter Ground
13	TDis	Input Logic Low Level to Switch Laser "ON" Input Logic High Level to Switch Laser "OFF"
14	TD+	Transmitter Data in
15	TD-	Transmitter Data In (Inverted)
16	V <sub>EET</sub>	Transmitter Ground
17	BM-	Laser Diode Bias Current Monitor-Negative End
18	BM+	Laser Diode Bias Current Monitor-Positive End
19	TPM-	Transmitter Power Monitor-Negative End
20	TPM+	Transmitter Power Monitor-Positive End

# Single-mode 155Mbps 2X10 SFF Transceiver

## Application Notes

Recommended AC Coupling Interface Circuit :

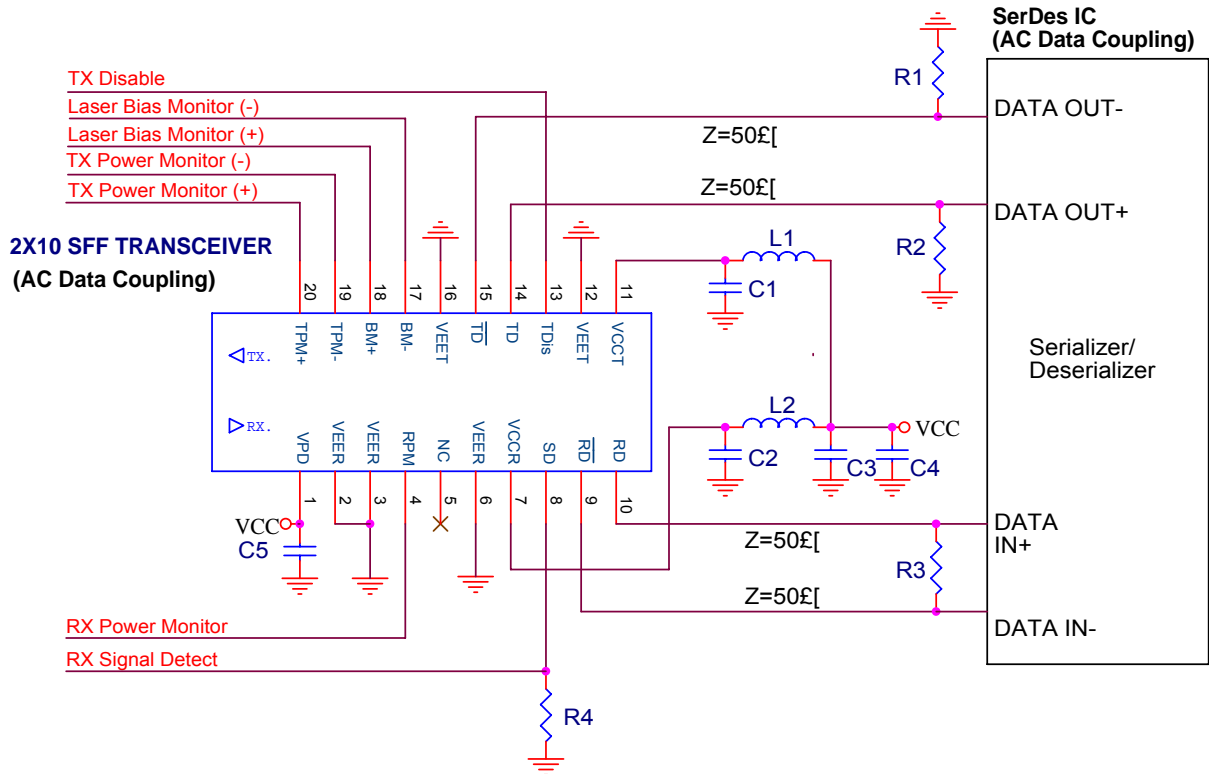

$L1=L2=1\text{gH}$  or ferrite bead  
 $C1=C2=C3=0.1\text{gF}$   
 $C4=10\text{gF}$   
 $C5=1\text{gF}$   
 R1, R2, R3 depends on SerDes IC specification.  
 (Consult the SerDes IC application information)  
 $R4=510\text{g}$

### NOTE<sub>i</sub>G

1. Transmission line characteristic impedance  $Z=50\text{g}$
2. R1, R2, R3 as close to SerDes IC as possible.

# Single-mode 155Mbps 2X10 SFF Transceiver

Recommended DC Coupling Interface Circuit :

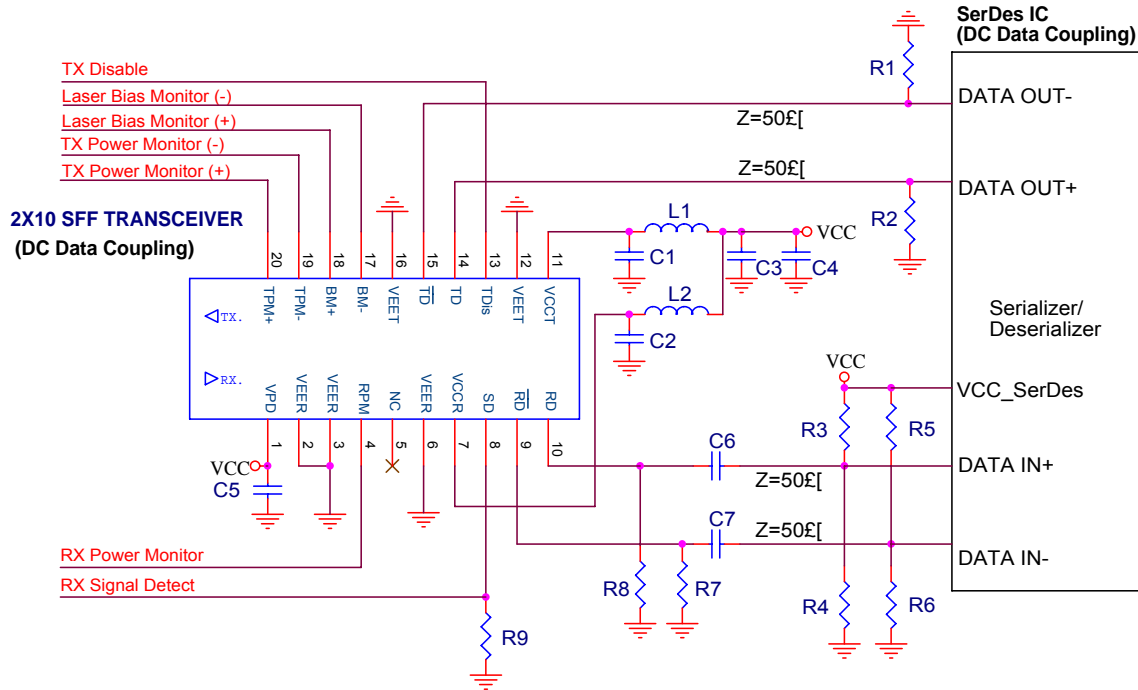

$L1=L2=1\mu\text{gH}$  or ferrite bead  
 $C1=C2=C3=C6=C7=0.1\mu\text{gF}$   
 $C4=10\mu\text{gF}$   
 $C5=1\mu\text{gF}$   
 $R1, R2, R3, R4, R5, R6$  depends on SerDes IC specification.  
 (Consult the SerDes IC application information)  
 $R7=R8=270\Omega$  (VCC=3.3V)  
 $=510\Omega$  (VCC=5V)  
 $R9=510\Omega$

NOTE:G  
 1. Transmission line characteristic impedance  $Z=50\Omega$   
 2. R1, R2, R3, R4, R5, R6 as close to SerDes IC as possible.  
 3. R7, R8 as close to 1X9 Transceiver as possible.

**Appointech, Inc.**  
 6F-2, NO.192 Tung-Kuan Rd.,  
 Hsinchu, Taiwan, R.O.C.  
 TEL : 886-3-573-8478  
 FAX : 886-3-573-8441  
 E-mail : sales@appointech.com  
 http://www.appointech.com

**US Office :**  
**Versatek, Inc.**  
 TEL : (714)630-5222  
 FAX : (714)630-5051