

# 74ACT11244 OCTAL BUFFER/LINE DRIVER WITH 3-STATE OUTPUTS

SCAS006C – AUGUST 1987 – REVISED APRIL 1996

- 3-State Outputs Drive Bus Lines or Buffer Memory Address Registers
- Inputs Are TTL-Voltage Compatible
- Flow-Through Architecture Optimizes PCB Layout
- Center-Pin  $V_{CC}$  and GND Configurations to Minimize High-Speed Switching Noise
- EPIC™ (Enhanced-Performance Implanted CMOS) 1- $\mu$ m Process
- 500-mA Typical Latch-Up Immunity at 125°C
- Package Options Include Plastic Small-Outline (DW), Shrink Small-Outline (DB), and Thin Shrink Small-Outline (PW) Packages, and Standard Plastic 300-mil DIPs (NT)

DB, DW, NT, OR PW PACKAGE  
(TOP VIEW)

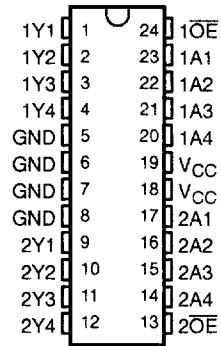

## description

This octal buffer or line driver is designed specifically to improve both the performance and density of 3-state memory address drivers, clock drivers, and bus-oriented receivers and transmitters. Together with the 74ACT11240, this device provides the choice of various combinations of inverting and noninverting outputs.

The 74ACT11244 is characterized for operation from -40°C to 85°C.

FUNCTION TABLE

OUTPUT ENABLE	DATA INPUT A	OUTPUT Y
$1OE, 2OE$	A	Y
H	X	Z
L	L	L
L	H	H

## logic symbol†

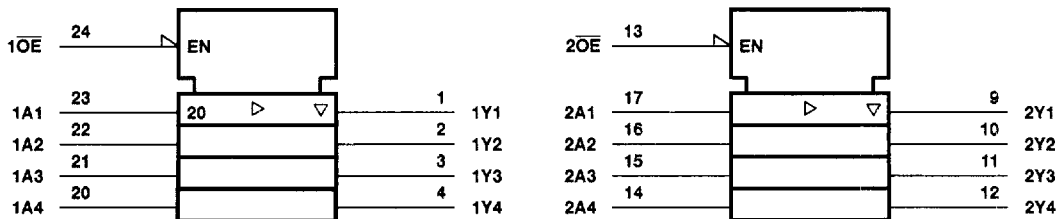

† This symbol is in accordance with ANSI/IEEE Std 91-1984 and IEC Publication 617-12.

EPIC is a trademark of Texas Instruments Incorporated.

PRODUCTION DATA Information is current as of publication date. Products conform to specifications per the terms of Texas Instruments standard warranty. Production processing does not necessarily include testing of all parameters.



POST OFFICE BOX 655303 • DALLAS, TEXAS 75265

Copyright © 1996, Texas Instruments Incorporated

**74ACT11244**  
**OCTAL BUFFER/LINE DRIVER**  
**WITH 3-STATE OUTPUTS**  
 SCAS006C – AUGUST 1987 – REVISED APRIL 1996

**logic diagram (positive logic)**

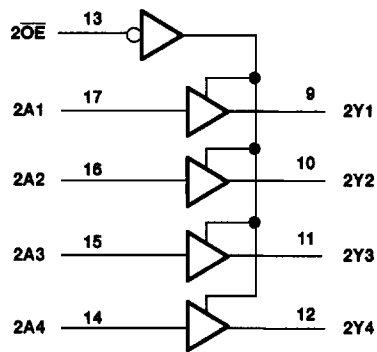
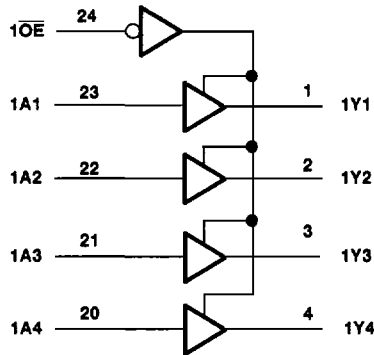

**absolute maximum ratings over operating free-air temperature range (unless otherwise noted)†**

Supply voltage range, $V_{CC}$ .....	-0.5 V to 6 V
Input voltage range, $V_I$ (see Note 1) .....	-0.5 V to $V_{CC} + 0.5$ V
Output voltage range, $V_O$ (see Note 1) .....	-0.5 V to $V_{CC} + 0.5$ V
Input clamp current, $I_{IK}$ ( $V_I < 0$ or $V_I > V_{CC}$ ) .....	$\pm 20$ mA
Output clamp current, $I_{OK}$ ( $V_O < 0$ or $V_O > V_{CC}$ ) .....	$\pm 50$ mA
Continuous output current, $I_O$ ( $V_O = 0$ to $V_{CC}$ ) .....	$\pm 50$ mA
Continuous current through $V_{CC}$ or GND .....	$\pm 200$ mA
Maximum power dissipation at $T_A = 55^\circ\text{C}$ (in still air) (see Note 2):	
DB package .....	0.65 W
DW package .....	1.7 W
NT package .....	1.3 W
PW package .....	0.7 W
Storage temperature range, $T_{stg}$ .....	$-65^\circ\text{C}$ to $150^\circ\text{C}$

† Stresses beyond those listed under “absolute maximum ratings” may cause permanent damage to the device. These are stress ratings only, and functional operation of the device at these or any other conditions beyond those indicated under “recommended operating conditions” is not implied. Exposure to absolute-maximum-rated conditions for extended periods may affect device reliability.

- NOTES: 1. The input and output voltage ratings may be exceeded if the input and output current ratings are observed.  
 2. The maximum package power dissipation is calculated using a junction temperature of  $150^\circ\text{C}$  and a board trace length of 750 mils, except for the NT package, which has a trace length of zero.

**recommended operating conditions**

		MIN	MAX	UNIT
$V_{CC}$	Supply voltage	4.5	5.5	V
$V_{IH}$	High-level input voltage	2		V
$V_{IL}$	Low-level input voltage		0.8	V
$V_I$	Input voltage	0	$V_{CC}$	V
$V_O$	Output voltage	0	$V_{CC}$	V
$I_{OH}$	High-level output current		-24	mA
$I_{OL}$	Low-level output current		24	mA
$\Delta V/\Delta t$	Input transition rise or fall rate	0	10	ns/V
$T_A$	Operating free-air temperature	-40	85	$^\circ\text{C}$



**74ACT11244**  
**OCTAL BUFFER/LINE DRIVER**  
**WITH 3-STATE OUTPUTS**  
 SCAS008C – AUGUST 1987 – REVISED APRIL 1996

**electrical characteristics over recommended operating free-air temperature range (unless otherwise noted)**

PARAMETER	TEST CONDITIONS	V <sub>CC</sub>	T <sub>A</sub> = 25°C			MIN	MAX	UNIT
			MIN	TYP	MAX			
V <sub>OH</sub>	I <sub>OH</sub> = -50 μA	4.5 V	4.4			4.4	V	
		5.5 V	5.4			5.4		
	I <sub>OH</sub> = -24 mA	4.5 V	3.94			3.8		
		5.5 V	4.94			4.8		
I <sub>OH</sub> = -75 mA†	5.5 V				3.85			
V <sub>OL</sub>	I <sub>OL</sub> = 50 μA	4.5 V			0.1	0.1	V	
		5.5 V			0.1	0.1		
	I <sub>OL</sub> = 24 mA	4.5 V			0.36	0.44		
		5.5 V			0.36	0.44		
I <sub>OL</sub> = 75 mA†	5.5 V				1.65			
I <sub>OZ</sub>	V <sub>O</sub> = V <sub>CC</sub> or GND	5.5 V			±0.5	±5	μA	
I <sub>I</sub>	V <sub>I</sub> = V <sub>CC</sub> or GND	5.5 V			±0.1	±1	μA	
I <sub>CC</sub>	V <sub>I</sub> = V <sub>CC</sub> or GND, I <sub>O</sub> = 0	5.5 V			8	80	μA	
ΔI <sub>CC</sub> ‡	One input at 3.4 V, Other inputs at GND or V <sub>CC</sub>	5.5 V			0.9	1	mA	
C <sub>i</sub>	V <sub>I</sub> = V <sub>CC</sub> or GND	5 V			4		pF	
C <sub>o</sub>	V <sub>O</sub> = V <sub>CC</sub> or GND	5 V			10		pF	

† Not more than one output should be tested at a time, and the duration of the test should not exceed 10 ms.

‡ This is the increase in supply current for each input that is at one of the specified TTL voltage levels rather than 0 V or V<sub>CC</sub>.

**switching characteristics over recommended operating free-air temperature range, V<sub>CC</sub> = 5 V ± 0.5 V (unless otherwise noted) (see Figure 1)**

PARAMETER	FROM (INPUT)	TO (OUTPUT)	T <sub>A</sub> = 25°C			MIN	MAX	UNIT
			MIN	TYP	MAX			
t <sub>PLH</sub>	A	Y	1.5	6	8.9	1.5	9.9	ns
t <sub>PHL</sub>			1.5	5.4	8.6	1.5	9.2	
t <sub>PZH</sub>	OE	Y	1.5	6.6	11.3	1.5	12.5	ns
t <sub>PZL</sub>			1.5	6.7	10.5	1.5	11.4	
t <sub>PHZ</sub>	OE	Y	1.5	7.4	9.8	1.5	10.4	ns
t <sub>PLZ</sub>			1.5	7.8	10.6	1.5	11.2	

**operating characteristics, V<sub>CC</sub> = 5 V, T<sub>A</sub> = 25°C**

PARAMETER		TEST CONDITIONS	TYP	UNIT
C <sub>pd</sub>	Power dissipation capacitance per buffer	Outputs enabled	27	pF
		Outputs disabled	9	

**74ACT11244**  
**OCTAL BUFFER/LINE DRIVER**  
**WITH 3-STATE OUTPUTS**  
 SCAS006C – AUGUST 1987 – REVISED APRIL 1996

**PARAMETER MEASUREMENT INFORMATION**

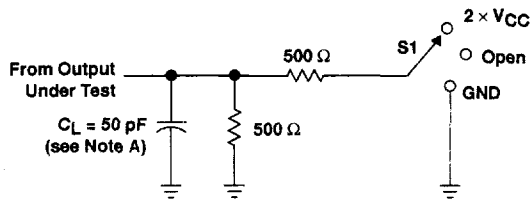

**LOAD CIRCUIT**

TEST	S1
$t_{PLH}/t_{PHL}$	Open
$t_{PLZ}/t_{PZL}$	2 $\times V_{CC}$
$t_{PHZ}/t_{PZH}$	GND

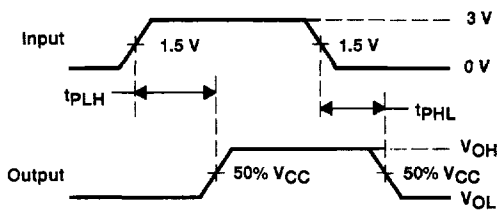

**VOLTAGE WAVEFORMS**

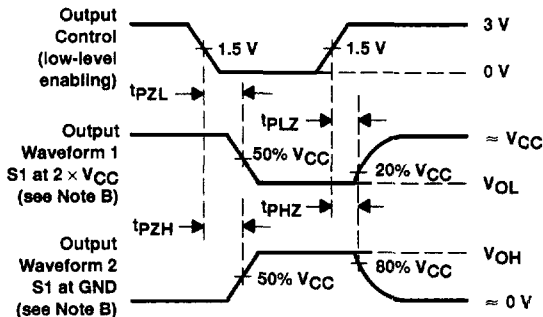

**VOLTAGE WAVEFORMS**

- NOTES: A.  $C_L$  includes probe and jig capacitance.  
 B. Waveform 1 is for an output with internal conditions such that the output is low except when disabled by the output control. Waveform 2 is for an output with internal conditions such that the output is high except when disabled by the output control.  
 C. All input pulses are supplied by generators having the following characteristics: PRR  $\leq 1 \text{ MHz}$ ,  $Z_O = 50 \Omega$ ,  $t_r = 3 \text{ ns}$ ,  $t_f = 3 \text{ ns}$ .  
 D. The outputs are measured one at a time with one input transition per measurement.

**Figure 1. Load Circuit and Voltage Waveforms**