

MM54HC137/MM74HC137 3-to-8 Line Decoder With Address Latches (Inverted Output)

General Description

This device utilizes advanced silicon-gate CMOS technology, to implement a three-to-eight line decoder with latches on the three address inputs. When $\overline{G1}$ goes from low to high, the address present at the select inputs (A, B and C) is stored in the latches. As long as $\overline{G1}$ remains high no address changes will be recognized. Output enable controls, $G1$ and $\overline{G2}$, control the state of the outputs independently of the select or latch-enable inputs. All of the outputs are high unless $G1$ is high and $\overline{G2}$ is low. The HC137 is ideally suited for the implementation of glitch-free decoders in stored-address applications in bus oriented systems.

The 54HC/74HC logic family is speed, function and pin-out compatible with the standard 54LS/74LS logic family. All inputs are protected from damage due to static discharge by diodes to V_{CC} and ground.

Features

- Typical propagation delay: 20 ns
- Wide supply range: 2-6V
- Latched inputs for easy interfacing.
- Fanout of 10 LS-TTL loads.

Connection and Functional Block Diagrams

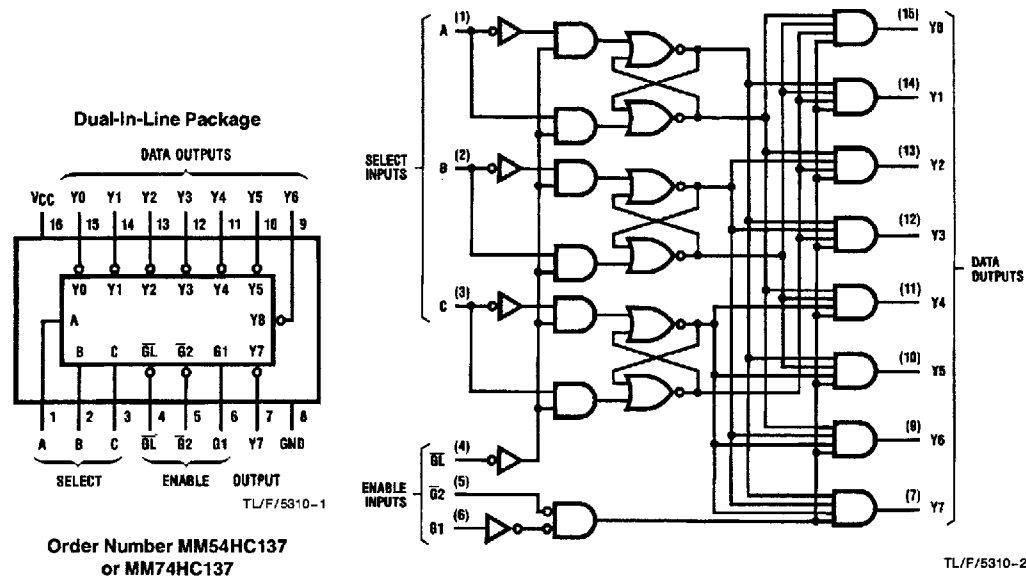

MM54HC137/MM74HC137 3-to-8 Line Decoder With Address Latches (Inverted Output)

Absolute Maximum Ratings (Notes 1 & 2)

If Military/Aerospace specified devices are required, please contact the National Semiconductor Sales Office/Distributors for availability and specifications.

Supply Voltage (V_{CC})	-0.5 to +7.0V
DC Input Voltage (V_{IN})	-1.5 to V_{CC} +1.5V
DC Output Voltage (V_{OUT})	-0.5 to V_{CC} +0.5V
Clamp Diode Current (I_{IK}, I_{OK})	±20 mA
DC Output Current, per pin (I_{OUT})	±25 mA
DC V_{CC} or GND Current, per pin (I_{CC})	±50 mA
Storage Temperature Range (T_{STG})	-65°C to +150°C
Power Dissipation (P_D)	
(Note 3)	600 mW
S.O. Package only	500 mW
Lead Temperature (T_L)	
(Soldering 10 seconds)	260°C

Operating Conditions

	Min	Max	Units
Supply Voltage (V_{CC})	2	6	V
DC Input or Output Voltage (V_{IN}, V_{OUT})	0	V_{CC}	V
Operating Temp. Range (T_A)			
MM74HC	-40	+85	°C
MM54HC	-55	+125	°C
Input Rise or Fall Times (t_r, t_f)			
$V_{CC}=2.0V$		1000	ns
$V_{CC}=4.5V$		500	ns
$V_{CC}=6.0V$		400	ns

DC Electrical Characteristics (Note 4)

Symbol	Parameter	Conditions	V_{CC}	$T_A = 25^\circ C$			Units	
				Typ	74HC $T_A = -40$ to $85^\circ C$	54HC $T_A = -55$ to $125^\circ C$		
V_{IH}	Minimum High Level Input Voltage		2.0V	1.5	1.5	1.5	V	
			4.5V	3.15	3.15	3.15	V	
			6.0V	4.2	4.2	4.2	V	
V_{IL}	Maximum Low Level Input Voltage**		2.0V	0.5	0.5	0.5	V	
			4.5V	1.35	1.35	1.35	V	
			6.0V	1.8	1.8	1.8	V	
V_{OH}	Minimum High Level Output Voltage	$V_{IN} = V_{IH}$ or V_{IL} $ I_{OUT} \leq 20 \mu A$	2.0V	2.0	1.9	1.9	V	
			4.5V	4.5	4.4	4.4	V	
			6.0V	6.0	5.9	5.9	V	
		$V_{IN} = V_{IH}$ or V_{IL} $ I_{OUT} \leq 4.0$ mA $ I_{OUT} \leq 5.2$ mA	4.5V		3.98	3.84	3.7	V
			6.0V		5.48	5.34	5.2	V
V_{OL}	Maximum Low Level Output Voltage	$V_{IN} = V_{IH}$ or V_{IL} $ I_{OUT} \leq 20 \mu A$	2.0V	0	0.1	0.1	V	
			4.5V	0	0.1	0.1	V	
			6.0V	0	0.1	0.1	V	
		$V_{IN} = V_{IH}$ or V_{IL} $ I_{OUT} \leq 4.0$ mA $ I_{OUT} \leq 5.2$ mA	4.5V		0.26	0.33	0.4	V
			6.0V		0.26	0.33	0.4	V
I_{IN}	Maximum Input Current	$V_{IN} = V_{CC}$ or GND	6.0V		±0.1	±1.0	±1.0	μA
I_{CC}	Maximum Quiescent Supply Current	$V_{IN} = V_{CC}$ or GND $I_{OUT} = 0 \mu A$	6.0V		8.0	80	160	μA

Note 1: Absolute Maximum Ratings are those values beyond which damage to the device may occur.

Note 2: Unless otherwise specified all voltages are referenced to ground.

Note 3: Power Dissipation temperature derating — plastic "N" package: -12 mW/°C from 65°C to 85°C; ceramic "J" package: -12 mW/°C from 100°C to 125°C.

Note 4: For a power supply of 5V ±10% the worst case output voltages (V_{OH} and V_{OL}) occur for HC at 4.5V. Thus the 4.5V values should be used when designing with this supply. Worst case V_{IH} and V_{IL} occur at $V_{CC}=5.5V$ and 4.5V respectively. (The V_{IH} value at 5.5V is 3.85V.) The worst case leakage current (I_{IN} , I_{CC} , and I_{OZ}) occur for CMOS at the higher voltage and so the 6.0V values should be used.

** V_{IL} limits are currently tested at 20% of V_{CC} . The above V_{IL} specification (30% of V_{CC}) will be implemented no later than Q1, CY'89.

AC Electrical Characteristics $V_{CC}=5V, T_A=25^{\circ}C, C_L=15\text{ pF}, t_r=t_f=6\text{ ns}$

Symbol	Parameter	Conditions	Typ	Guaranteed Limit	Units
t_{PLH}	Maximum Propagation Delay, A, B or C to any Y Output		14	29	ns
t_{PHL}	Maximum Propagation Delay, A, B or C to any Y Output		20	42	ns
t_{PLH}	Maximum Propagation Delay $\overline{G2}$ to any Y Output		12	22	ns
t_{PHL}	Maximum Propagation Delay $\overline{G2}$ to any Y Output		15	34	ns
t_{PLH}	Maximum Propagation Delay G1 to any Output		13	25	ns
t_{PHL}	Maximum Propagation Delay GL to any Output		17	34	ns
t_{PLH}	Maximum Propagation Delay GL to Output		15	30	ns
t_{PHL}	Maximum Propagation Delay GL to Output		22	34	ns
t_S	Minimum Setup Time at A, B and C Inputs			20	ns
t_H	Minimum Hold Time at A, B and C Inputs			0	ns
t_W	Minimum Pulse Width of Enabling Pulse at \overline{GL}			16	ns

AC Electrical Characteristics $C_L=50\text{ pF}, t_r=t_f=6\text{ ns}$ (unless otherwise specified)

Symbol	Parameter	Conditions	V_{CC}	$T_A=25^{\circ}C$		74HC	54HC	Units
				Typ		$T_A=-40\text{ to }85^{\circ}C$	$T_A=-55\text{ to }125^{\circ}C$	
				Guaranteed Limits				
t_{PLH}	Maximum Propagation Delay A, B or C to any Y Output		2.0V	85	170	214	253	ns
			4.5V	17	34	43	51	ns
			6.0V	14	29	36	43	ns
t_{PHL}	Maximum Propagation Delay A, B or C to any Y Output		2.0V	120	240	302	358	ns
			4.5V	24	48	60	72	ns
			6.0V	20	41	51	61	ns
t_{PLH}	Maximum Propagation Delay $\overline{G2}$ to any Y Output		2.0V	65	130	164	194	ns
			4.5V	13	26	33	39	ns
			6.0V	11	22	28	33	ns
t_{PLH}	Maximum Propagation Delay G1 to Output		2.0V	75	150	189	224	ns
			4.5V	15	30	38	45	ns
			6.0V	13	26	32	38	ns
t_{PHL}	Maximum Propagation Delay G1 to Output		2.0V	98	195	246	291	ns
			4.5V	20	39	49	58	ns
			6.0V	17	33	42	49	ns
t_{PLH}	Maximum Propagation Delay GL to Output		2.0V	88	175	221	261	ns
			4.5V	18	35	44	52	ns
			6.0V	15	30	37	44	ns
t_{PHL}	Maximum Propagation Delay GL to Output		2.0V	125	250	315	373	ns
			4.5V	25	50	63	75	ns
			6.0V	21	43	54	63	ns
t_{PHL}	Maximum Propagation Delay $\overline{G2}$, to any Y Output		2.0V	98	195	246	291	ns
			4.5V	20	39	49	58	ns
			6.0V	17	33	42	49	ns
t_S	Minimum Setup Time at A, B and C inputs		2.0V		100	125	150	ns
			4.5V		20	25	30	ns
			6.0V		17	21	25	ns
t_H	Minimum Hold Time at A, B and C inputs		2.0V		50	63	75	ns
			4.5V		10	13	15	ns
			6.0V		8	11	13	ns
t_{TLH}, t_{THL}	Output Rise and Fall Time		2.0V	30	75	95	110	ns
			4.5V	8	15	19	22	ns
			6.0V	7	13	16	19	ns
t_W	Minimum Pulse Width of Enabling Pulse at \overline{GL}		2.0V		80	100	120	ns
			4.5V		16	20	24	ns
			6.0V		14	18	21	ns
C_{PD}	Power Dissipation Capacitance (Note 5)			75				pF
C_{IN}	Maximum Input Capacitance			5	10	10	10	pF

Note 5: C_{PD} determines the no load dynamic power consumption, $P_D = C_{PD} V_{CC}^2 f + I_{CC} V_{CC}$, and the no load dynamic current consumption, $I_S = C_{PD} V_{CC} f + I_{CC}$.

Typical Application

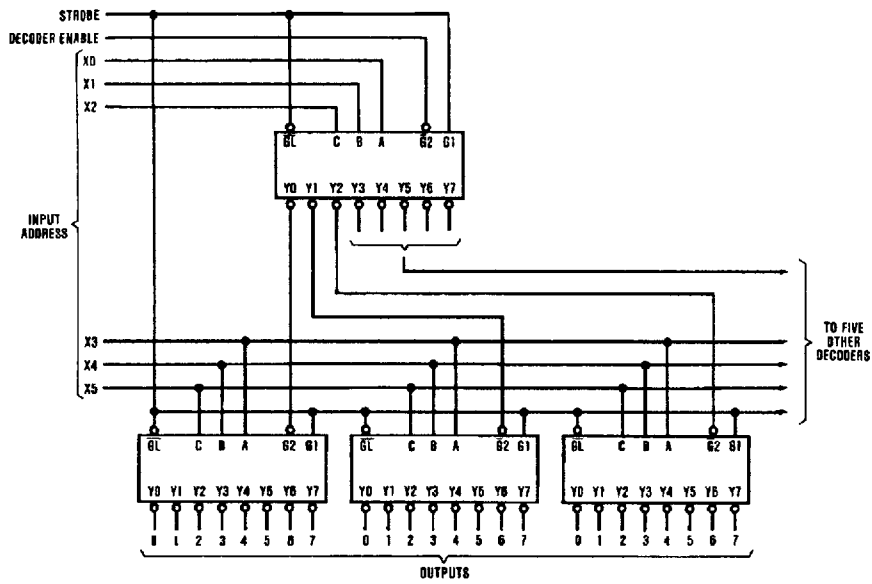

6-Line to 64-Line Decoder with Input Address Storage

TL/F/6310-3

Truth Table

Inputs					Outputs								
Enable			Select										
$\overline{G1}$	G1	$\overline{G2}$	C	B	A	Y0	Y1	Y2	Y3	Y4	Y5	Y6	Y7
X	X	H	X	X	X	H	H	H	H	H	H	H	H
X	L	X	X	X	X	H	H	H	H	H	H	H	H
L	H	L	L	L	L	L	H	H	H	H	H	H	H
L	H	L	L	L	H	H	L	H	H	H	H	H	H
L	H	L	L	H	L	H	H	L	H	H	H	H	H
L	H	L	L	H	H	H	H	H	L	H	H	H	H
L	H	L	H	L	H	H	H	H	H	L	H	H	H
L	H	L	H	H	L	H	H	H	H	H	L	H	H
L	H	L	H	H	H	H	H	H	H	H	H	L	H
H	H	L	X	X	X	Output corresponding to stored address L; all others, H							

H = high level, L = low level, X = irrelevant

MM54HC137/MM74HC137 3-to-8 Line Decoder With Address Latches (Inverted Output)

Physical Dimensions inches (millimeters)

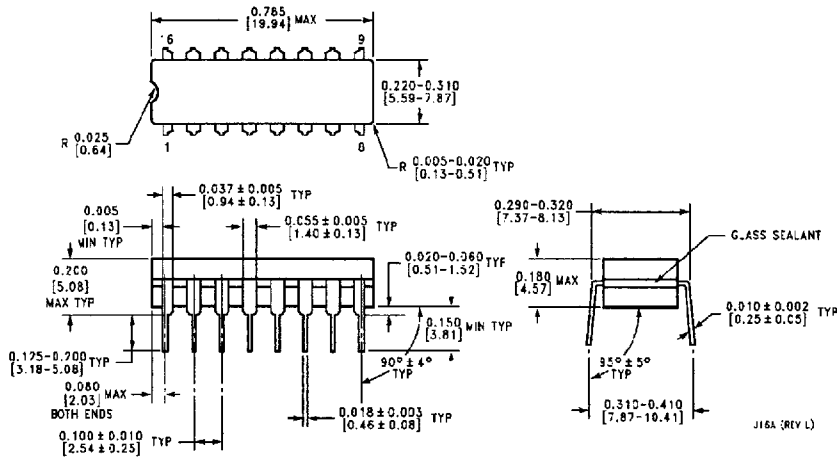

Ceramic Dual-In-Line Package (J)
Order Number MM54HC137J or MM74HC137J
NS Package J16A

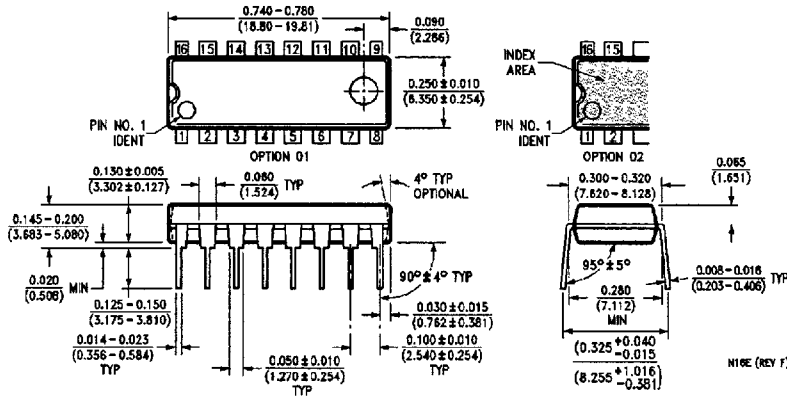

Molded Dual-In-Line Package (N)
Order Number MM74HC137N
NS Package N16E

LIFE SUPPORT POLICY

NATIONAL'S PRODUCTS ARE NOT AUTHORIZED FOR USE AS CRITICAL COMPONENTS IN LIFE SUPPORT DEVICES OR SYSTEMS WITHOUT THE EXPRESS WRITTEN APPROVAL OF THE PRESIDENT OF NATIONAL SEMICONDUCTOR CORPORATION. As used herein:

1. Life support devices or systems are devices or systems which, (a) are intended for surgical implant into the body, or (b) support or sustain life, and whose failure to perform, when properly used in accordance with instructions for use provided in the labeling, can be reasonably expected to result in a significant injury to the user.
2. A critical component is any component of a life support device or system whose failure to perform can be reasonably expected to cause the failure of the life support device or system, or to affect its safety or effectiveness.



National Semiconductor Corporation
 1111 West Bardin Road
 Arlington, TX 76017
 Tel: 1(800) 272-9959
 Fax: 1(800) 737-7018

National Semiconductor Europe
 Fax: (+49) 0-180-530 85 86
 Email: onjwge@levm2.nsc.com
 Deutsch Tel: (+49) 0-180-530 85 85
 English Tel: (+49) 0-180-532 78 32
 Français Tel: (+49) 0-180-532 83 58
 Italiano Tel: (+49) 0-180-534 16 80

National Semiconductor Hong Kong Ltd.
 13th Floor, Straight Block,
 Ocean Centre, 5 Canton Rd,
 Tsimshatsui, Kowloon
 Hong Kong
 Tel: (852) 2737-1800
 Fax: (852) 2736-9960

National Semiconductor Japan Ltd.
 Tel: 81-043-299-2309
 Fax: 81-043-299-2408

National does not assume any responsibility for use of any circuitry described, no circuit patent licenses are implied and National reserves the right at any time without notice to change said circuitry and specifications.

5