

MOS INTEGRATED CIRCUIT

μPD42S16170L, 42S17170L, 42S18170L

16 M BIT DYNAMIC RAM
(3.3V FAST PAGE MODE & BYTE WRITE MODE)

PRELIMINARY

DESCRIPTION

The NEC μPD42S16170L, μPD42S17170L and μPD42S18170L are 1 048 576 words by 16 bits dynamic CMOS RAM with optional fast page mode. CMOS sense amplifier, peripheral circuits and 1 transistor memory cell technique realize high speed access, cycle time and low power dissipation.

Refresh is accomplished by performing $\overline{\text{RAS}}$ only refresh cycles, hidden refresh cycles, $\overline{\text{CAS}}$ before $\overline{\text{RAS}}$ refresh cycles, $\overline{\text{CAS}}$ before $\overline{\text{RAS}}$ self refresh cycles or normal read or write cycles on the 4096 address combinations of A0 to A11 (for μPD42S16170L) or 2048 address combinations of A0 to A10 (for μPD42S17170L) or 1024 address combinations of A0 to A9 (for μPD42S18170L) during a 256 ms period.

The μPD42S16170L, μPD42S17170L and μPD42S18170L are packaged in 42-pin plastic SOJ and 50-pin plastic TSOP.

FEATURES

- 1 048 576 words by 16 bits organization
- Single +3.3V±0.3V power supply
- On-chip substrate bias generator
- Non latched I/O, TTL-compatible
- Multiplexed address inputs
- Read-modify-write, Fast Page Mode and Byte Write Mode capability
- $\overline{\text{RAS}}$ only refresh, hidden refresh and $\overline{\text{CAS}}$ before $\overline{\text{RAS}}$ internal address refresh
- $\overline{\text{CAS}}$ before $\overline{\text{RAS}}$ self refresh

DEVICE	Row Address	Column Address	Refresh cycle
μPD42S16170L	A0 to A11	A0 to A7	4096 cycles/256 ms
μPD42S17170L	A0 to A10	A0 to A8	2048 cycles/256 ms
μPD42S18170L	A0 to A9	A0 to A9	1024 cycles/256 ms

● 4 performance ranges

DEVICE	ACCESS TIME (MAX.)	R/W CYCLE (MIN.)	PAGE MODE CYCLE (MIN.)	Low power dissipation	
				Active (MAX.)	Standby
μPD42S16170L-A60	60 ns	110 ns	40 ns	324 mW	0.36 mW (MAX.) (CMOS level)
μPD42S17170L-A60				396 mW	
μPD42S18170L-A60				540 mW	
μPD42S16170L-A70	70 ns	130 ns	45 ns	288 mW	
μPD42S17170L-A70				360 mW	
μPD42S18170L-A70				504 mW	
μPD42S16170L-A80	80 ns	150 ns	50 ns	252 mW	
μPD42S17170L-A80				324 mW	
μPD42S18170L-A80				468 mW	

μPD42S16170L, 42S17170L, 42S18170L

ORDERING INFORMATION

PART NUMBER	ACCESS TIME (MAX.)	PACKAGE	QUALITY GRADE
μ PD42S16170LLE-A60	60ns	42-pin Plastic SOJ	STANDARD
μ PD42S17170LLE-A60			
μ PD42S18170LLE-A60			
μ PD42S16170LLE-A70	70ns		
μ PD42S17170LLE-A70			
μ PD42S18170LLE-A70			
μ PD42S16170LLE-A80	80ns		
μ PD42S17170LLE-A80			
μ PD42S18170LLE-A80			
μ PD42S16170LG5-A60-7JF	60ns	50-pin Plastic TSOP	STANDARD
μ PD42S17170LG5-A60-7JF			
μ PD42S18170LG5-A60-7JF			
μ PD42S16170LG5-A70-7JF	70ns		
μ PD42S17170LG5-A70-7JF			
μ PD42S18170LG5-A70-7JF			
μ PD42S16170LG5-A80-7JF	80ns		
μ PD42S17170LG5-A80-7JF			
μ PD42S18170LG5-A80-7JF			
μ PD42S16170LG5-A60-7KF	60ns	50-pin Plastic TSOP (Reverse bent)	STANDARD
μ PD42S17170LG5-A60-7KF			
μ PD42S18170LG5-A60-7KF			
μ PD42S16170LG5-A70-7KF	70ns		
μ PD42S17170LG5-A70-7KF			
μ PD42S18170LG5-A70-7KF			
μ PD42S16170LG5-A80-7KF	80ns		
μ PD42S17170LG5-A80-7KF			
μ PD42S18170LG5-A80-7KF			

Please refer to "Quality grade on NEC Semiconductor Devices" (Document number IEI-1209) published by NEC Corporation to know the specification of quality grade on the devices and its recommended applications.

μPD42S16170L, 42S17170L, 42S18170L

PIN CONFIGURATION (Marking Side)

- A0 to A9/A10/A11 : Address Inputs
- I/01 to I/016 : Data Inputs/Outputs
- $\overline{\text{RAS}}$: Row Address Strobe
- $\overline{\text{CAS}}$: Column Address Strobe
- $\overline{\text{UW}}$: Upper Byte Write Enable
- $\overline{\text{LW}}$: Lower Byte Write Enable
- OE : Output Enable
- V_{cc} : Supply Voltage
- GND : Ground
- NC : No Connection

42-pin Plastic SOJ (400 mil)

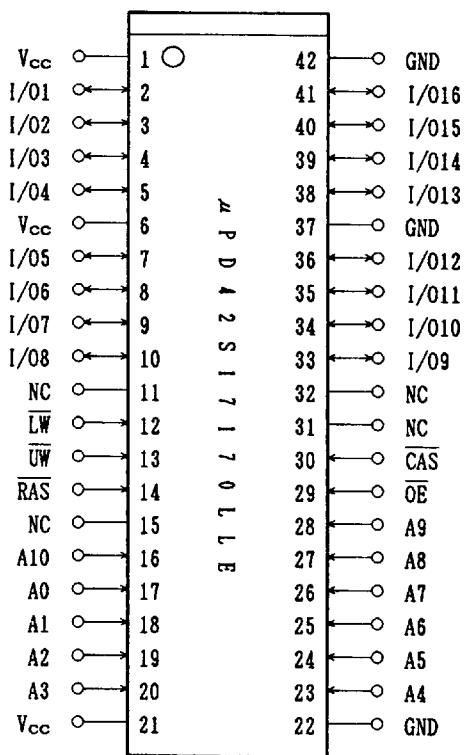
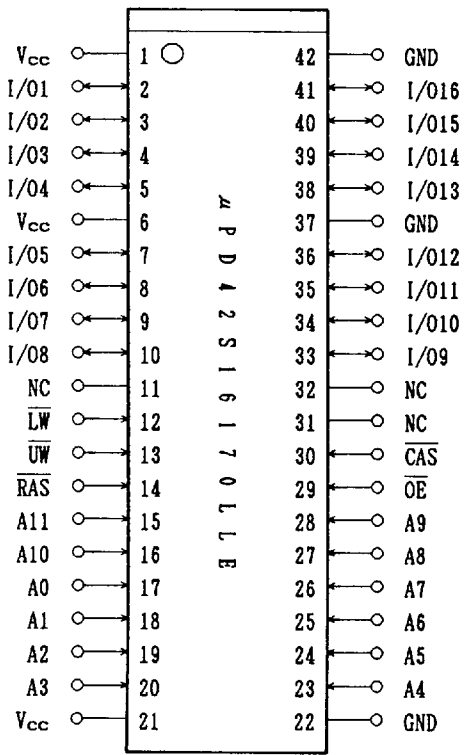

42-pin Plastic SOJ (400 mil)

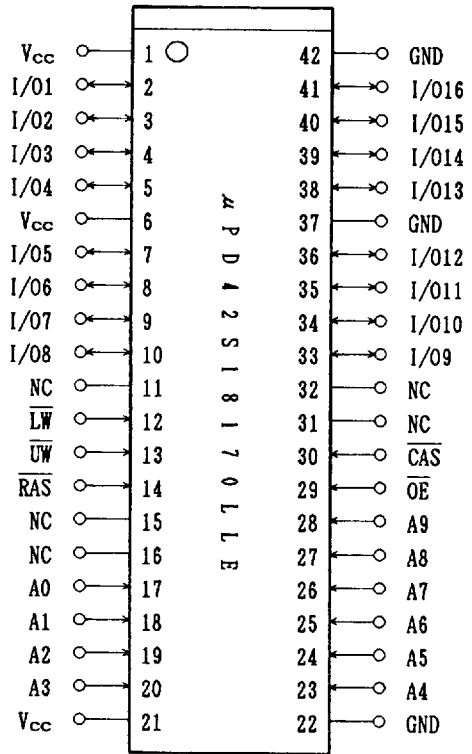

μ PD42S16170L, 42S17170L, 42S18170L

50-pin Plastic TSOP (400 mil)

【 μ PD42S16170L】

Reverse bent

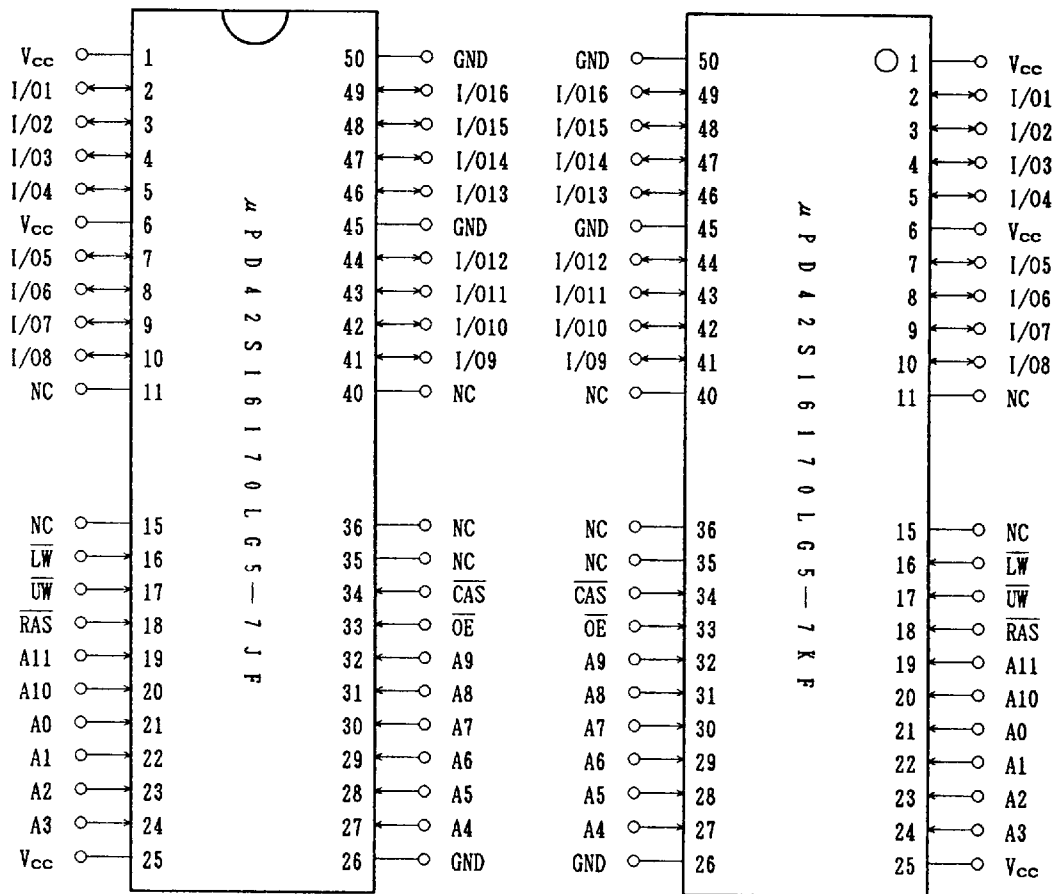

μ PD42S16170L,42S17170L,42S18170L

【 μ PD42S17170L】

Reverse bent

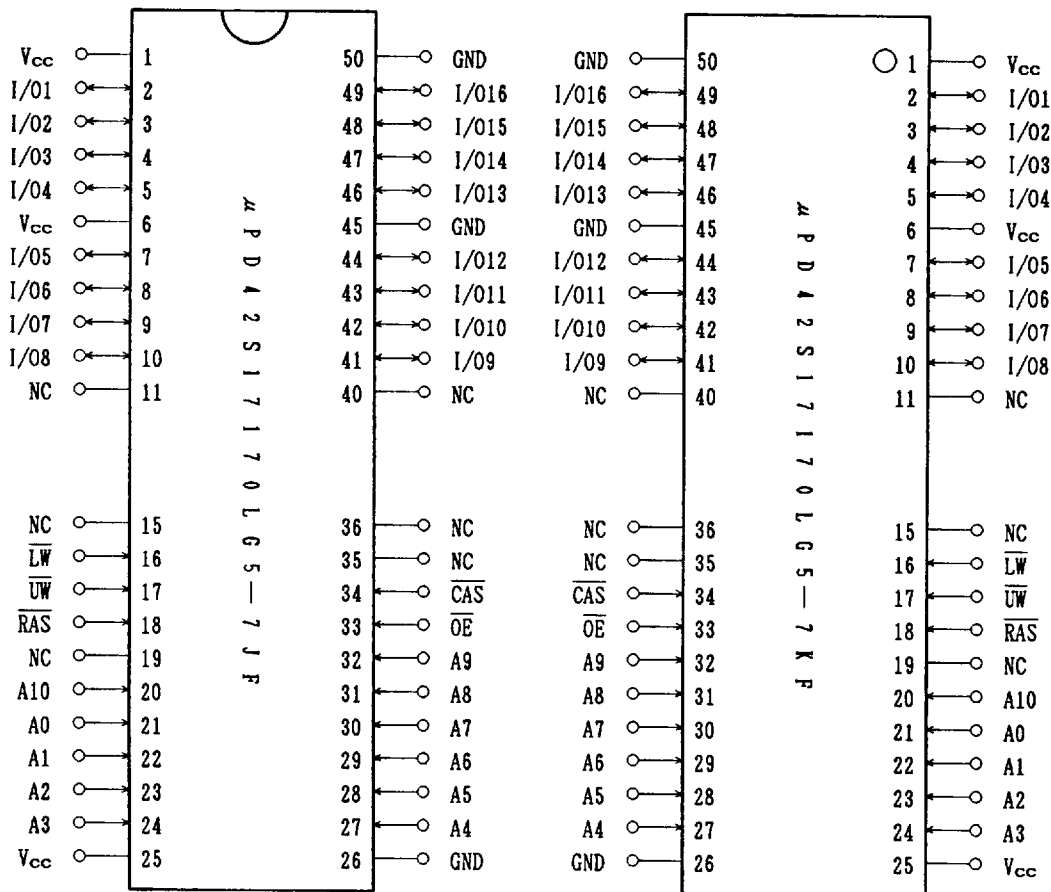

μPD42S16170L, 42S17170L, 42S18170L

【μPD42S18170L】

Reverse bent

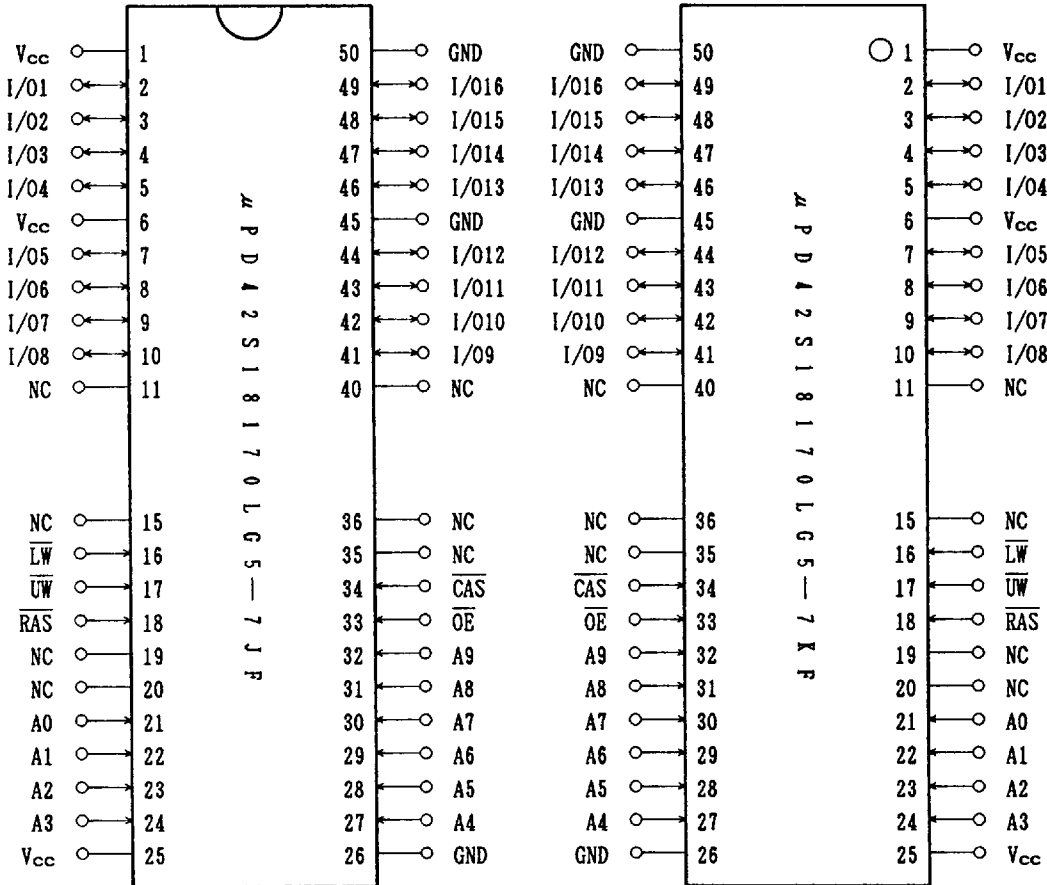

μPD42S16170L,42S17170L,42S18170L

ELECTRICAL SPECIFICATIONS

ABSOLUTE MAXIMUM RATINGS*

PARAMETER	SYMBOL	TEST CONDITION	RATING	UNIT
Voltage on Any Pin Relative to GND	V_T		-0.5 to +4.6	V
Short Circuit Output Current	I_o		20	mA
Power Dissipation	P_D		1	W
Operating Temperature	T_{opt}		0 to 70	°C
Storage Temperature	T_{stg}		-55 to +125	°C

*COMMENT : Exposing the device to stress above those listed in Absolute Maximum Ratings could cause permanent damage. The device is not meant to be operated under conditions outside the limits described in the operational sections of this specification. Exposure to Absolute Maximum Rating conditions for extended periods may affect device reliability.

RECOMMENDED OPERATING CONDITIONS NOTES:1,2

PARAMETER	SYMBOL	TEST CONDITION	MIN.	TYP.	MAX.	UNIT
Supply Voltage	V_{CC}		3.0	3.3	3.6	V
High Level Input Voltage	V_{IH}		2.0		$V_{CC}+0.3$	V
Low Level Input Voltage	V_{IL}		-0.3		0.8	V
Ambient Temperature	T_a		0		70	°C

CAPACITANCE ($T_a=25^\circ\text{C}$, $f=1\text{ MHz}$)

PARAMETER	SYMBOL	TEST CONDITION	MIN.	TYP.	MAX.	UNIT
Input Capacitance	C_{i1}	A0 to A9/A10/A11			5	pF
	C_{i2}	RAS, CAS, \overline{UW} , \overline{LW} , \overline{OE}			7	pF
Data Input/Output Capacitance	C_D	I/01 to I/016			7	pF

μPD42S16170L, 42S17170L, 42S18170L

DC CHARACTERISTICS (Recommended Operating Conditions unless Otherwise noted)

【μPD42S16170L】

PARAMETER	SYMBOL	TEST CONDITION	MIN.	TYP.	MAX.	UNIT	NOTES
Operating Current	I _{CC1}	$\overline{\text{RAS}}, \overline{\text{CAS}}$ Cycling $t_{\text{RC}}=t_{\text{RC}(\text{MIN.})}, I_{\text{O}}=0\text{mA}$	μPD42S16170L-A60		90	mA	3
			μPD42S16170L-A70		80		
			μPD42S16170L-A80		70		
Standby Current	I _{CC2}	$\overline{\text{RAS}}, \overline{\text{CAS}} \geq V_{\text{IH}(\text{MIN.})}, I_{\text{O}}=0\text{mA}$			0.5	mA	
		$\overline{\text{RAS}}, \overline{\text{CAS}} \geq V_{\text{CC}}-0.2\text{V}, I_{\text{O}}=0\text{mA}$			0.1		
Refresh Current (RAS Only Refresh)	I _{CC3}	$\overline{\text{RAS}}$ Cycling, $\overline{\text{CAS}} \geq V_{\text{IH}(\text{MIN.})}$ $t_{\text{RC}}=t_{\text{RC}(\text{MIN.})}, I_{\text{O}}=0\text{mA}$	μPD42S16170L-A60		90	mA	3
			μPD42S16170L-A70		80		
			μPD42S16170L-A80		70		
Operating Current (Fast Page Mode)	I _{CC4}	$\overline{\text{CAS}}$ Cycling, $\overline{\text{RAS}} \leq V_{\text{IL}(\text{MAX.})}$ $t_{\text{PC}}=t_{\text{PC}(\text{MIN.})}, I_{\text{O}}=0\text{mA}$	μPD42S16170L-A60		90	mA	3
			μPD42S16170L-A70		80		
			μPD42S16170L-A80		70		
Refresh Current (CAS before RAS Refresh)	I _{CC5}	$\overline{\text{RAS}}$ Cycling, $t_{\text{RC}}=t_{\text{RC}(\text{MIN.})}, I_{\text{O}}=0\text{mA}$	μPD42S16170L-A60		90	mA	3
			μPD42S16170L-A70		80		
			μPD42S16170L-A80		70		
Battery back-up Current (Standby with $\overline{\text{CAS}}$ before RAS Refresh)	I _{CC6}	Standby: $V_{\text{CC}}-0.2\text{V} \leq \overline{\text{RAS}},$ CAS before $\overline{\text{RAS}}$ Refresh: 4096 Cycle/256 ms $\overline{\text{RAS}}, \overline{\text{CAS}}: 0\text{V} \leq V_{\text{IL}} \leq 0.2\text{V}$ $V_{\text{CC}}-0.2\text{V} \leq V_{\text{IH}} \leq V_{\text{IH MAX.}}$ $\overline{\text{WE}}, \overline{\text{OE}}: V_{\text{IH}}$ Address: Don't care Output: OPEN	$t_{\text{RAS}} \leq 300\text{ns}$		140	μA	
			$t_{\text{RAS}} \leq 1\mu\text{s}$		140		
Self Refresh Current (CAS before RAS Self Refresh)	I _{CC7}	$\overline{\text{RAS}}, \overline{\text{CAS}}: 0\text{V} \leq V_{\text{IL}} \leq 0.2\text{V}$ $V_{\text{CC}}-0.2\text{V} \leq V_{\text{IH}} \leq V_{\text{IH MAX.}}, I_{\text{O}}=0\text{mA}$			80	μA	
Input Leakage Current	I _{I(L)}	V _I =0 to 3.6V, all other pins=0V	-5		5	μA	
Output Leakage Current	I _{O(L)}	D _{OUT} is disabled, V _O =0 to 3.6V	-5		5	μA	
Output High Voltage	V _{OH}	I _O =-2mA	2.4			V	
Output Low Voltage	V _{OL}	I _O =2mA			0.4	V	

μPD42S16170L, 42S17170L, 42S18170L

【μPD42S17170L】

PARAMETER	SYMBOL	TEST CONDITION	MIN.	TYP.	MAX.	UNIT	NOTES
Operating Current	I _{CC1}	$\overline{\text{RAS}}, \overline{\text{CAS}}$ Cycling $t_{\text{RC}}=t_{\text{RC(MIN.)}$, I _O =0mA	μPD42S17170L-A60		110	mA	3
			μPD42S17170L-A70		100		
			μPD42S17170L-A80		90		
Standby Current	I _{CC2}	$\overline{\text{RAS}}, \overline{\text{CAS}} \geq V_{\text{IH(MIN.)}}$, I _O =0mA			0.5	mA	
		$\overline{\text{RAS}}, \overline{\text{CAS}} \geq V_{\text{CC}}-0.2\text{V}$, I _O =0mA			0.1		
Refresh Current (RAS Only Refresh)	I _{CC3}	$\overline{\text{RAS}}$ Cycling, $\overline{\text{CAS}} \geq V_{\text{IH(MIN.)}}$ $t_{\text{RC}}=t_{\text{RC(MIN.)}$, I _O =0mA	μPD42S17170L-A60		110	mA	3
			μPD42S17170L-A70		100		
			μPD42S17170L-A80		90		
Operating Current (Fast Page Mode)	I _{CC4}	$\overline{\text{CAS}}$ Cycling, $\overline{\text{RAS}} \leq V_{\text{IL(MAX.)}}$ $t_{\text{PC}}=t_{\text{PC(MIN.)}$, I _O =0mA	μPD42S17170L-A60		90	mA	3
			μPD42S17170L-A70		80		
			μPD42S17170L-A80		70		
Refresh Current (CAS before RAS Refresh)	I _{CC5}	$\overline{\text{RAS}}$ Cycling, $t_{\text{RC}}=t_{\text{RC(MIN.)}$, I _O =0mA	μPD42S17170L-A60		110	mA	3
			μPD42S17170L-A70		100		
			μPD42S17170L-A80		90		
Battery back-up Current (Standby with $\overline{\text{CAS}}$ before RAS Refresh)	I _{CC6}	Standby: $V_{\text{CC}}-0.2\text{V} \leq \overline{\text{RAS}}$, $\overline{\text{CAS}}$ before $\overline{\text{RAS}}$ Refresh: 2048 Cycle/256 ms $\overline{\text{RAS}}, \overline{\text{CAS}}: 0\text{V} \leq V_{\text{IL}} \leq 0.2\text{V}$ $V_{\text{CC}}-0.2\text{V} \leq V_{\text{IH}} \leq V_{\text{IH MAX.}}$ $\overline{\text{WE}}, \overline{\text{OE}}: V_{\text{IH}}$ Address: Don't care Output: OPEN	$t_{\text{RAS}} \leq 300\text{ns}$		120	μA	
			$t_{\text{RAS}} \leq 1\mu\text{s}$		120		
Self Refresh Current (CAS before RAS Self Refresh)	I _{CC7}	$\overline{\text{RAS}}, \overline{\text{CAS}}: 0\text{V} \leq V_{\text{IL}} \leq 0.2\text{V}$ $V_{\text{CC}}-0.2\text{V} \leq V_{\text{IH}} \leq V_{\text{IH MAX.}}$, I _O =0mA			80	μA	
Input Leakage Current	I _{I(L)}	V _I =0 to 3.6V, all other pins= 0V	-5		5	μA	
Output Leakage Current	I _{O(L)}	D _{OUT} is disabled, V _O =0 to 3.6V	-5		5	μA	
Output High Voltage	V _{OH}	I _O =-2mA	2.4			V	
Output Low Voltage	V _{OL}	I _O =2mA			0.4	V	

μPD42S16170L, 42S17170L, 42S18170L

【μPD42S18170L】

PARAMETER	SYMBOL	TEST CONDITION	MIN.	TYP.	MAX.	UNIT	NOTES
Operating Current	I _{CC1}	$\overline{\text{RAS}}, \overline{\text{CAS}}$ Cycling $t_{\text{RC}} = t_{\text{RC}(\text{MIN.})}, I_{\text{O}} = 0\text{mA}$	μPD42S18170L-A60		150	mA	3
			μPD42S18170L-A70		140		
			μPD42S18170L-A80		130		
Standby Current	I _{CC2}	$\overline{\text{RAS}}, \overline{\text{CAS}} \geq V_{\text{IH}(\text{MIN.})}, I_{\text{O}} = 0\text{mA}$ $\overline{\text{RAS}}, \overline{\text{CAS}} \geq V_{\text{CC}} - 0.2\text{V}, I_{\text{O}} = 0\text{mA}$			0.5	mA	
					0.1		
Refresh Current (RAS Only Refresh)	I _{CC3}	$\overline{\text{RAS}}$ Cycling, $\overline{\text{CAS}} \geq V_{\text{IH}(\text{MIN.})}$ $t_{\text{RC}} = t_{\text{RC}(\text{MIN.})}, I_{\text{O}} = 0\text{mA}$	μPD42S18170L-A60		150	mA	3
			μPD42S18170L-A70		140		
			μPD42S18170L-A80		130		
Operating Current (Fast Page Mode)	I _{CC4}	$\overline{\text{CAS}}$ Cycling, $\overline{\text{RAS}} \leq V_{\text{IL}(\text{MAX.})}$ $t_{\text{PC}} = t_{\text{PC}(\text{MIN.})}, I_{\text{O}} = 0\text{mA}$	μPD42S18170L-A60		90	mA	3
			μPD42S18170L-A70		80		
			μPD42S18170L-A80		70		
Refresh Current (CAS before RAS Refresh)	I _{CC5}	$\overline{\text{RAS}}$ Cycling, $t_{\text{RC}} = t_{\text{RC}(\text{MIN.})}, I_{\text{O}} = 0\text{mA}$	μPD42S18170L-A60		150	mA	3
			μPD42S18170L-A70		140		
			μPD42S18170L-A80		130		
Battery back-up Current (Standby with $\overline{\text{CAS}}$ before $\overline{\text{RAS}}$ Refresh)	I _{CC6}	Standby: $V_{\text{CC}} - 0.2\text{V} \leq \overline{\text{RAS}},$ $\overline{\text{CAS}}$ before $\overline{\text{RAS}}$ Refresh: 1024 Cycle/256 ms $\overline{\text{RAS}}, \overline{\text{CAS}}: 0\text{V} \leq V_{\text{IL}} \leq 0.2\text{V}$ $V_{\text{CC}} - 0.2\text{V} \leq V_{\text{IH}} \leq V_{\text{IH MAX.}}$ $\overline{\text{WE}}, \overline{\text{OE}}: V_{\text{IH}}$ Address: Don't care Output: OPEN	$t_{\text{RAS}} \leq 300\text{ns}$		110	μA	
			$t_{\text{RAS}} \leq 1\mu\text{s}$		110		
Self Refresh Current (CAS before RAS Self Refresh)	I _{CC7}	$\overline{\text{RAS}}, \overline{\text{CAS}}: 0\text{V} \leq V_{\text{IL}} \leq 0.2\text{V}$ $V_{\text{CC}} - 0.2\text{V} \leq V_{\text{IH}} \leq V_{\text{IH MAX.}}, I_{\text{O}} = 0\text{mA}$			80	μA	
Input Leakage Current	I _{I(L)}	V _I =0 to 3.6V, all other pins= 0V	-5		5	μA	
Output Leakage Current	I _{O(L)}	D _{OUT} is disabled, V _O =0 to 3.6V	-5		5	μA	
Output High Voltage	V _{OH}	I _O =-2mA	2.4			V	
Output Low Voltage	V _{OL}	I _O =2mA			0.4	V	

μPD42S16170L,42S17170L,42S18170L

AC CHARACTERISTICS

(Recommended Operating Conditions unless Otherwise noted) **NOTES: 2,4,5**

(1/2)

PARAMETER	SYMBOL	μ PD42S16170L-A60	μ PD42S16170L-A70	μ PD42S16170L-A80	μ PD42S17170L-A60	μ PD42S17170L-A70	μ PD42S17170L-A80	UNIT	NOTES
		MIN.	MAX.	MIN.	MAX.	MIN.	MAX.		
Random Read or Write Cycle Time	t _{RC}	110		130		150		ns	6
Read Write Cycle Time	t _{RWC}	160		180		200		ns	6
Fast Page Mode Cycle Time(Read or Write)	t _{PC}	40		45		50		ns	6
Read Modify Write Cycle Time(Fast Page Mode)	t _{PRWC}	85		90		105		ns	6
Access Time from $\overline{\text{RAS}}$	t _{RAC}		60		70		80	ns	7, 8
Access Time from $\overline{\text{CAS}}$ (Falling Edge)	t _{CAC}		15		20		20	ns	7, 8
Access Time from Column Address	t _{AA}		30		35		40	ns	7, 8
Access Time from $\overline{\text{CAS}}$ Precharge	t _{ACP}		35		40		45	ns	7
Access Time from $\overline{\text{OE}}$	t _{OEA}		15		20		20	ns	
$\overline{\text{RAS}}$ to Column Address Delay Time	t _{RAD}	15	30	15	35	17	40	ns	8
$\overline{\text{CAS}}$ -Data Set-up Time	t _{CLZ}	0		0		0		ns	7
$\overline{\text{OE}}$ -Data Set-up Time	t _{OLZ}	0		0		0		ns	7
Output Buffer Turn-off Delay ($\overline{\text{CAS}}$)	t _{OPF}	0	13	0	15	0	15	ns	9
$\overline{\text{OE}}$ Data Delay Time	t _{OED}	13		15		15		ns	
Output Buffer Turn-off Delay ($\overline{\text{OE}}$)	t _{OEZ}	0	13	0	15	0	15	ns	9
$\overline{\text{OE}}$ Command Hold Time	t _{OEH}	0		0		0		ns	
$\overline{\text{OE}}$ to $\overline{\text{RAS}}$ inactive Set-up Time	t _{OES}	0		0		0		ns	
Transition Time (Rise and Fall)	t _T	3	50	3	50	3	50	ns	
$\overline{\text{RAS}}$ Precharge Time	t _{RP}	40		50		60		ns	
$\overline{\text{RAS}}$ Pulse Width (Random Read, Write Cycle)	t _{RAS}	60	10000	70	10000	80	10000	ns	
$\overline{\text{RAS}}$ Pulse Width (Fast Page Mode)	t _{RASP}	60	125000	70	125000	80	125000	ns	
$\overline{\text{RAS}}$ Hold Time	t _{RSH}	15		18		20		ns	
$\overline{\text{CAS}}$ Pulse Width	t _{CAS}	15	10000	20	10000	20	10000	ns	
$\overline{\text{CAS}}$ Hold Time	t _{CSH}	60		70		80		ns	
$\overline{\text{RAS}}$ to $\overline{\text{CAS}}$ Delay Time	t _{RCD}	20	45	20	50	25	60	ns	8
$\overline{\text{CAS}}$ to $\overline{\text{RAS}}$ Precharge Time	t _{CRP}	5		5		5		ns	10
$\overline{\text{CAS}}$ Precharge Time	t _{CPN}	10		10		10		ns	
$\overline{\text{CAS}}$ Precharge Time (Fast Page Mode)	t _{CP}	10		10		10		ns	
$\overline{\text{RAS}}$ Precharge $\overline{\text{CAS}}$ Hold Time	t _{RPC}	5		5		5		ns	
$\overline{\text{RAS}}$ Hold Time from $\overline{\text{CAS}}$ Precharge	t _{RHCP}	35		40		45		ns	
Row Address Set-up Time	t _{ASR}	0		0		0		ns	
Row Address Hold Time	t _{RAH}	10		10		12		ns	

μPD42S16170L,42S17170L,42S18170L

(2/2)

PARAMETER	SYMBOL	μ PD42S16170L-A60	μ PD42S17170L-A60	μ PD42S18170L-A60	μ PD42S16170L-A70	μ PD42S17170L-A70	μ PD42S18170L-A70	μ PD42S16170L-A80	μ PD42S17170L-A80	μ PD42S18170L-A80	UNIT	NOTES
		MIN.	MIN.	MAX.	MAX.	MIN.	MAX.	MIN.	MAX.			
Column Address Set-up Time	t _{ASC}	0			0			0			ns	
Column Address Hold Time	t _{CAH}	15			15			15			ns	
Column Address Lead Time Referenced to $\overline{\text{RAS}}$	t _{RAL}	30			35			40			ns	
Read Command Set-up Time	t _{RCS}	0			0			0			ns	
Read Command Hold Time Referenced to $\overline{\text{RAS}}$	t _{RRH}	0			0			0			ns	11
Read Command Hold Time Referenced to $\overline{\text{CAS}}$	t _{RCH}	0			0			0			ns	11
Write Command Hold Time Referenced to $\overline{\text{CAS}}$	t _{WCH}	10			10			15			ns	12
Write Command Pulse Width	t _{WP}	10			10			15			ns	12
Data-in Set-up Time	t _{DS}	0			0			0			ns	13
Data-in Hold Time	t _{DH}	10			15			15			ns	13
$\overline{\text{WE}}$ Command Set-up Time	t _{WCS}	0			0			0			ns	14
$\overline{\text{CAS}}$ Precharge to $\overline{\text{WE}}$ Delay Time(Fast Page)	t _{CPWD}	60			65			70			ns	15
$\overline{\text{CAS}}$ to $\overline{\text{WE}}$ Delay	t _{CWD}	38			40			45			ns	15
$\overline{\text{RAS}}$ to $\overline{\text{WE}}$ Delay	t _{RWD}	83			95			105			ns	15
Column Address to $\overline{\text{WE}}$ Delay Time	t _{AWD}	53			60			65			ns	15
Write Command to $\overline{\text{RAS}}$ Lead Time	t _{RWL}	20			20			20			ns	
Write Command to $\overline{\text{CAS}}$ Lead Time	t _{CWL}	15			15			15			ns	
$\overline{\text{CAS}}$ Set-up Time for CBR Refresh	t _{CSR}	5			5			5			ns	
$\overline{\text{CAS}}$ Hold Time for CBR Refresh	t _{CHR}	10			10			10			ns	
Masked Write Set-up Time	t _{MCS}	0			0			0			ns	
Masked Write Hold Time Referenced to $\overline{\text{RAS}}$	t _{MRH}	0			0			0			ns	
Masked Write Hold Time Referenced to $\overline{\text{CAS}}$	t _{MCH}	0			0			0			ns	
$\overline{\text{RAS}}$ Pulse Width (Self Refresh Cycle)	t _{RASS}	100			100			100			μs	
$\overline{\text{RAS}}$ Precharge Time (Self Refresh Cycle)	t _{RPS}	110			130			150			ns	
$\overline{\text{CAS}}$ Hold Time (Self Refresh Cycle)	t _{CHS}	-50			-50			-50			ns	
Refresh Period	t _{REF}		256			256			256		ms	16

NOTES:

- All voltages referenced to GND.
- An initial pause of 100 μ s required after power-on followed by 8 refresh ($\overline{\text{RAS}}$ only refresh or CAS before RAS refresh) cycles before proper device operation is achieved.
- I_{CC1} , I_{CC3} , I_{CC4} and I_{CC5} depend on output loading and cycle rates. Specified values are obtained with the output open. In addition to this, I_{CC3} is measured on condition that column addresses in RAS only cycle are held high or low level and I_{CC4} is measured on condition that column addresses in fast page mode are changed only one time during $t_{PC(MIN.)}$.
- AC measurements assume $t_T=5\text{ns}$
- $V_{IH(MIN.)}$ and $V_{IL(MAX.)}$ are reference levels for measuring timing of input signals. Transition times are measured between V_{IH} and V_{IL} .
- The minimum specifications are used only to indicate cycle time at which proper operation over the full temperature range ($T_a=0$ to 70°C) is assured.
- Load = 1 TTL loads and 100pF ($V_{OH}=2.0\text{V}$, $V_{OL}=0.8\text{V}$)
- The access time is determined by RAS access time t_{RAC} , address access time t_{AA} , and $\overline{\text{CAS}}$ address time t_{CAC} . The relationship between these access time and t_{RCD} , t_{RAD} is as follows.

CONDITION	ACCESS TIME
$t_{RAD} \leq t_{RAD(MAX.)}$ and $t_{RCD} \leq t_{RCD(MAX.)}$	$t_{RAC(MAX.)}$
$t_{RAD} \geq t_{RAD(MAX.)}$	$t_{AA(MAX.)}$
$t_{RCD} \geq t_{RCD(MAX.)}$	$t_{CAC(MAX.)}$

- $t_{OFF(MAX.)}$ and $t_{OBZ(MAX.)}$ defines the time at which the output achieves the open circuit condition and is not referenced to V_{OH} or V_{OL} .
- t_{CRP} requirement should be applicable for RAS/CAS cycles preceded by any cycles.
- Either t_{RRH} or t_{RCH} must be satisfied for a read cycle.
- t_{WP} is applicable for late write cycle. If the cycle is early write, it should be satisfied value of t_{WR} .
- These parameters are referenced to $\overline{\text{CAS}}$ leading edge in early write cycles and to $\overline{\text{UW/LW}}$ leading edge in late write or read-modify-write cycles.
- If $t_{WCS} \geq t_{WCS(MIN.)}$ the cycle is an early write cycle and the data output will remain open circuit throughout the entire cycle.
- If $t_{CPWD} \geq t_{CPWD(MIN.)}$, $t_{CWD} \geq t_{CWD(MIN.)}$, $t_{RWD} \geq t_{RWD(MIN.)}$, $t_{AWD} \geq t_{AWD(MIN.)}$ the cycle is a read-write and the data output will contain data read from the selected cell. If neither of the above conditions are met, the condition of the data out (at access time and until $\overline{\text{CAS}}$ goes back to V_{IH}) is indeterminate.
- How to enter into $\overline{\text{CAS}}$ before RAS self refresh mode.
 - In case of using distributed $\overline{\text{CAS}}$ before RAS refresh
Refresh 4096 or 2048 or 1024 times during a 256ms (Before set into the $\overline{\text{CAS}}$ before RAS self refresh mode, and after reset).
 - In case of using burst CAS before RAS refresh
Refresh 4096 times during a 64ms (μ PD42S16170L) or 2048 times during a 32ms (μ PD42S17170L) or 1024 times during a 16ms (μ PD42S18170L) (Before set into the $\overline{\text{CAS}}$ before RAS self refresh mode, and after reset).
 - In case of use $\overline{\text{RAS}}$ only refresh
Refresh against all refresh address during 64ms (μ PD42S16170L) or 32ms (μ PD42S17170L) or 16ms (μ PD42S18170L) (Before set into the $\overline{\text{CAS}}$ before RAS self refresh mode, and after reset).

TIMING DIAGRAMS

READ CYCLE

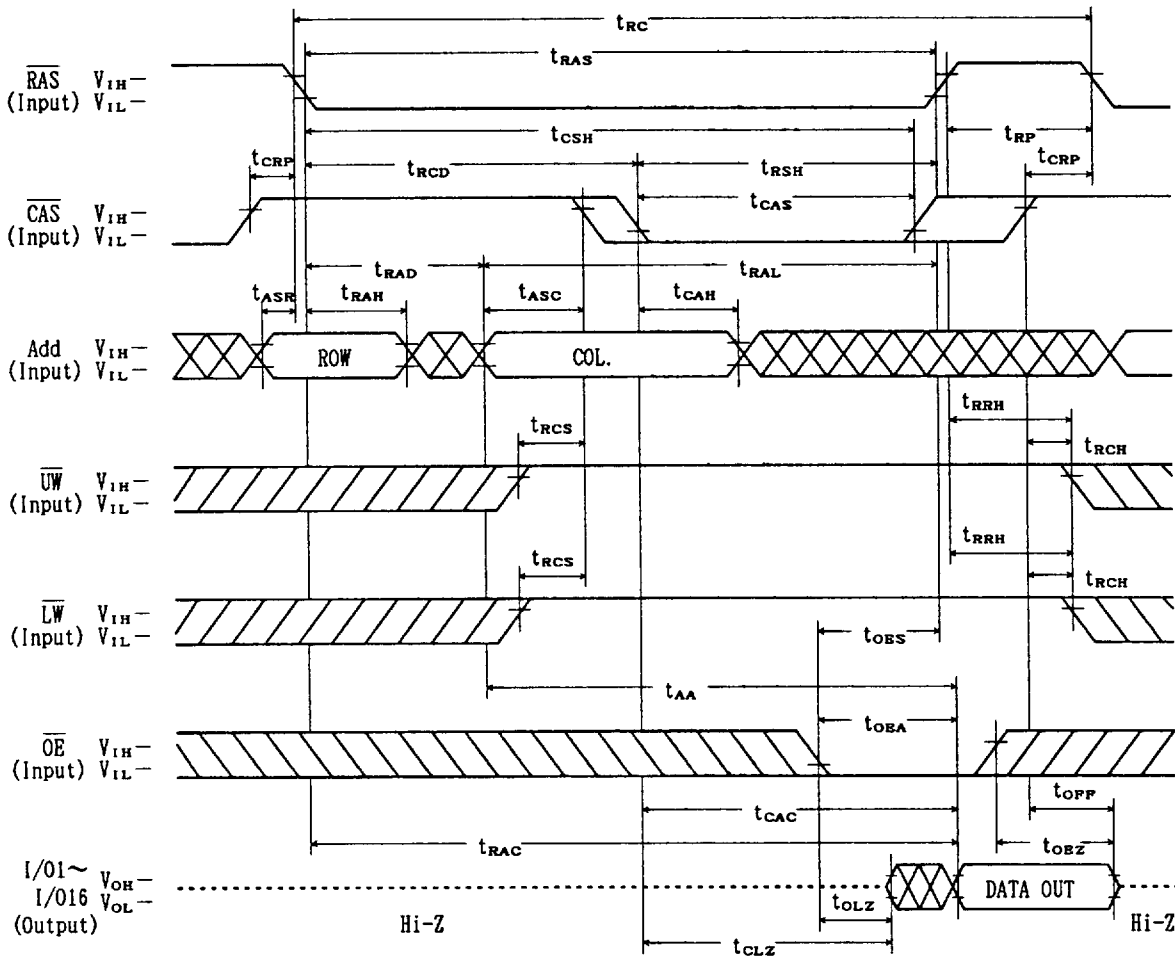

μ PD42S16170L, 42S17170L, 42S18170L

EARLY WRITE CYCLE

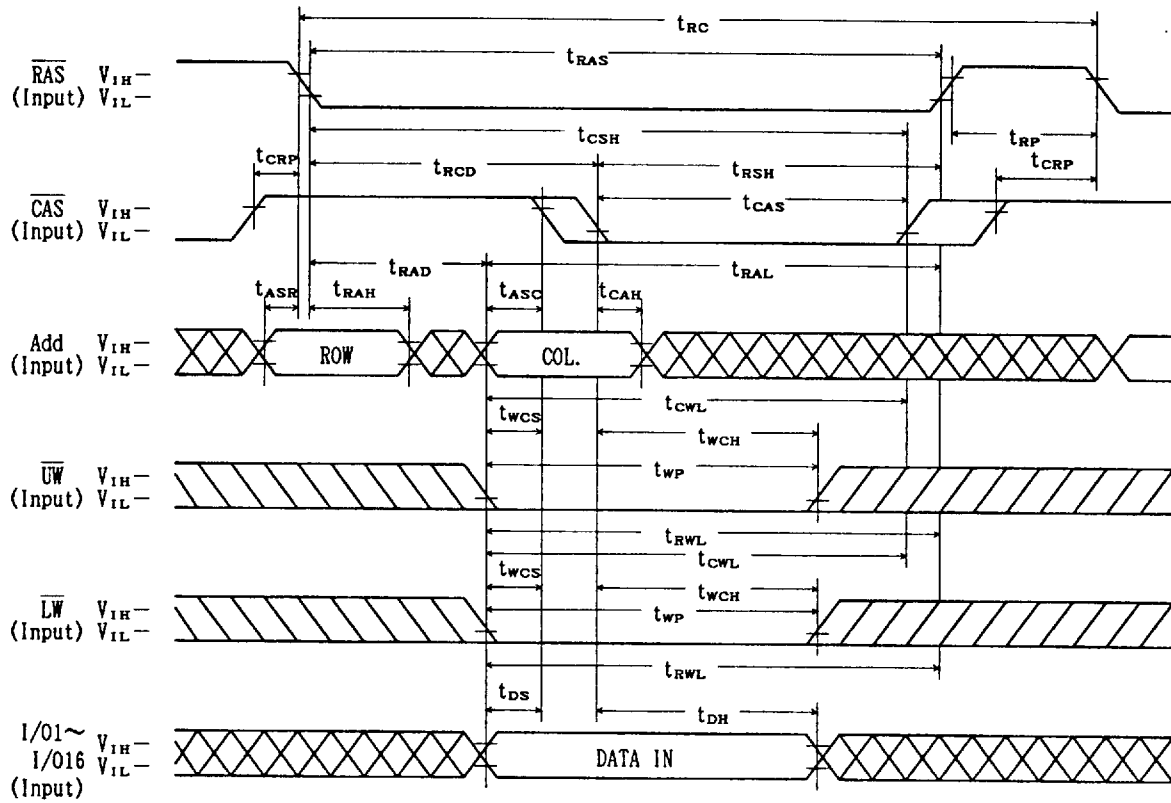

Note: $\overline{\text{OE}}$ = Don't care

μ PD42S16170L, 42S17170L, 42S18170L

UPPER BYTE EARLY WRITE CYCLE

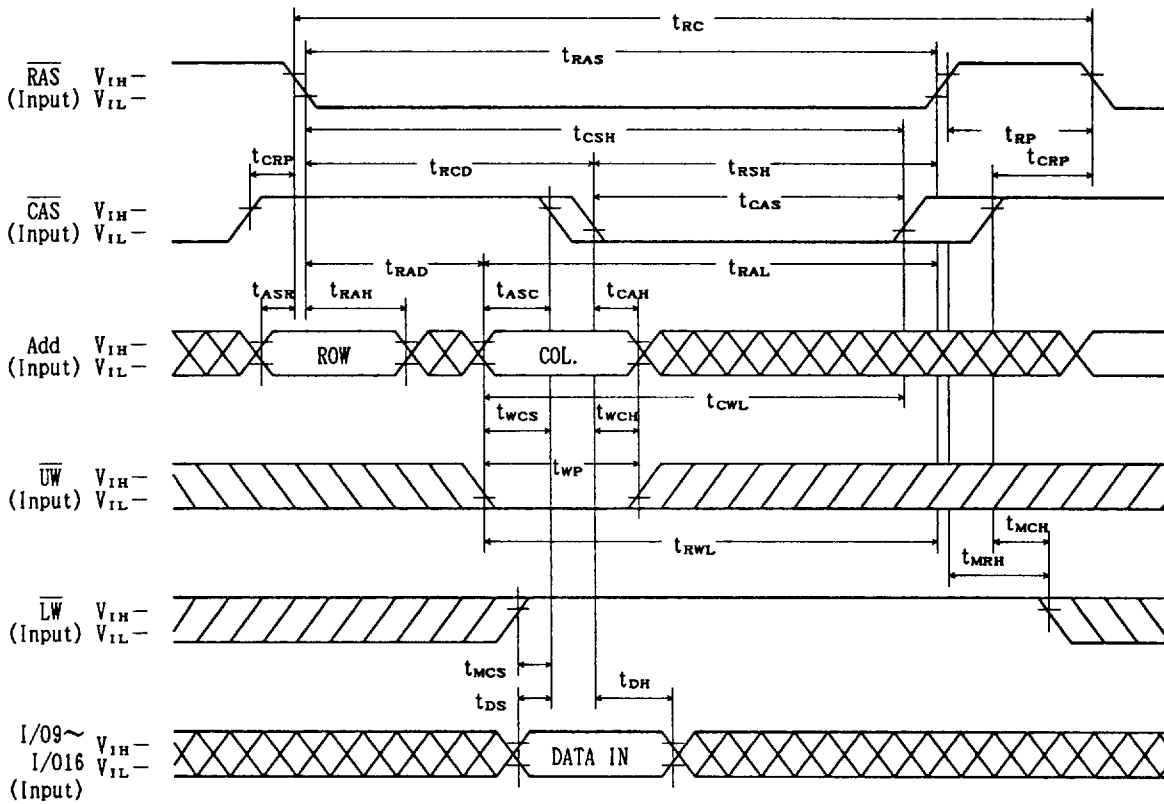

Note: \overline{OE} , I/O1~I/O8 = Don't care

μ PD42S16170L, 42S17170L, 42S18170L

LOWER BYTE EARLY WRITE CYCLE

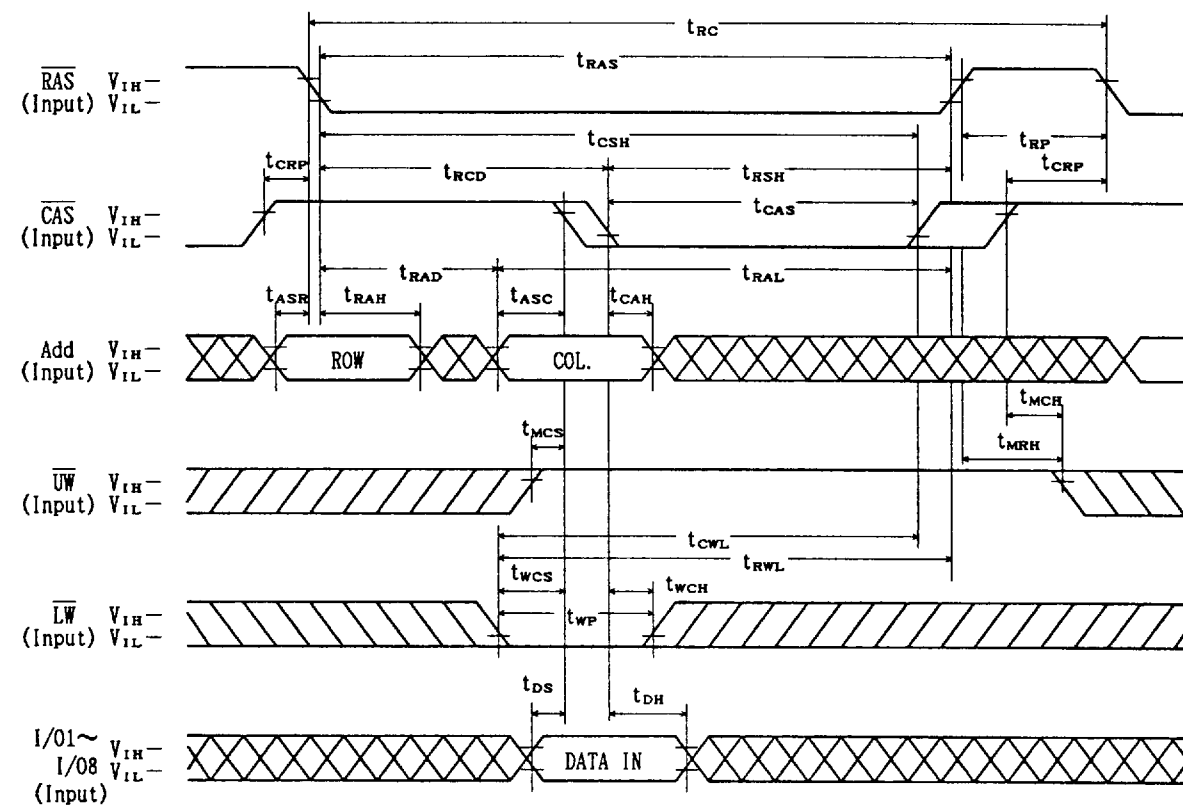

Note: \overline{OE} , I/09~I/016=Don't care

LATE WRITE CYCLE

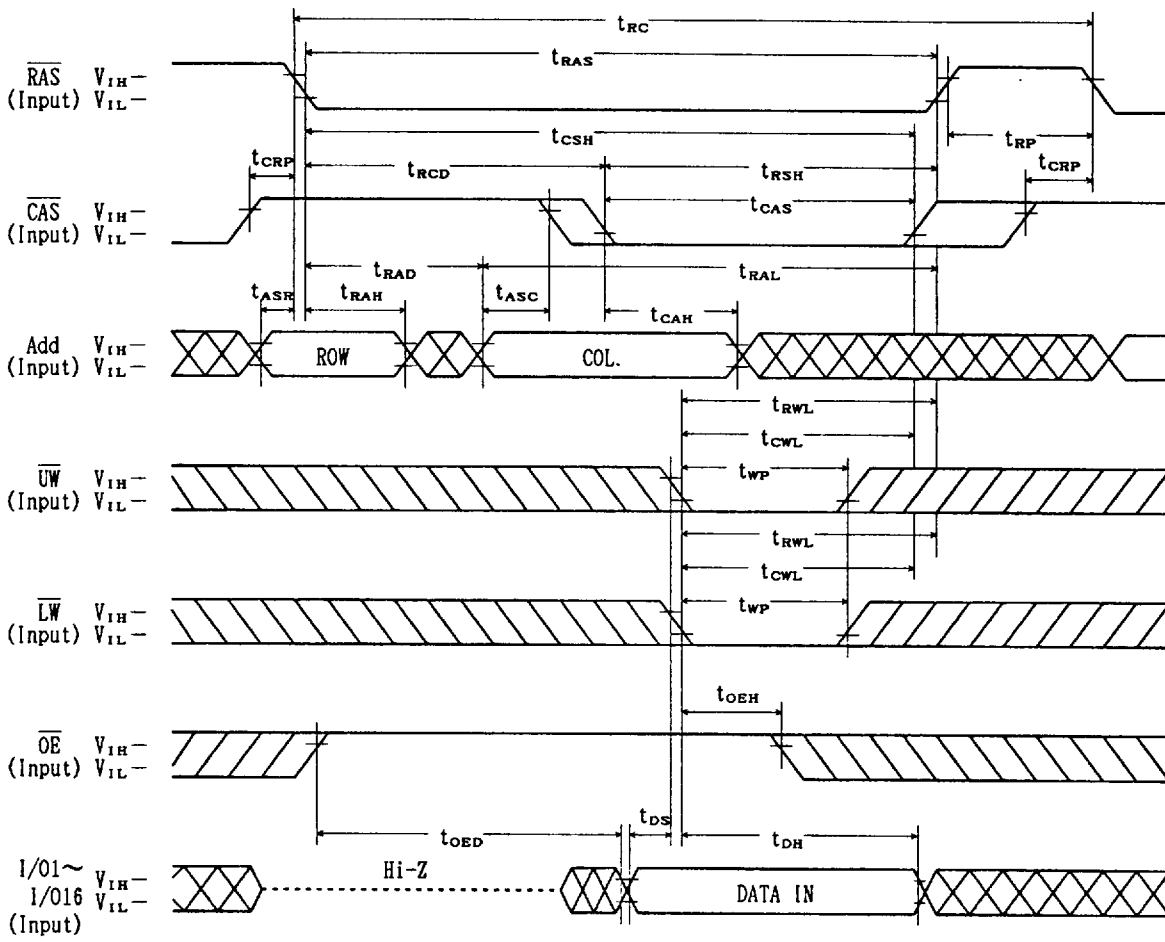

UPPER BYTE LATE WRITE CYCLE

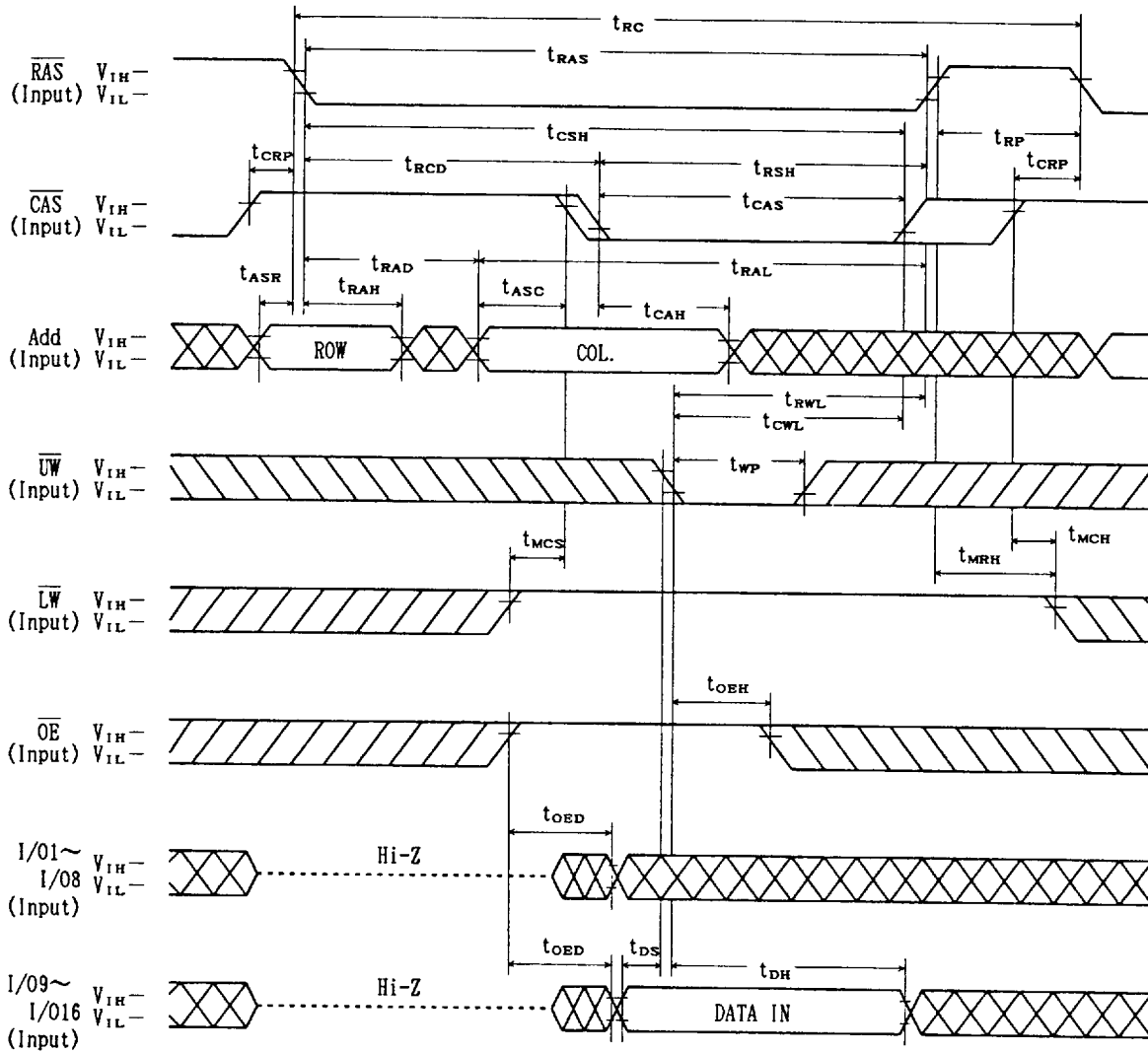

LOWER BYTE LATE WRITE CYCLE

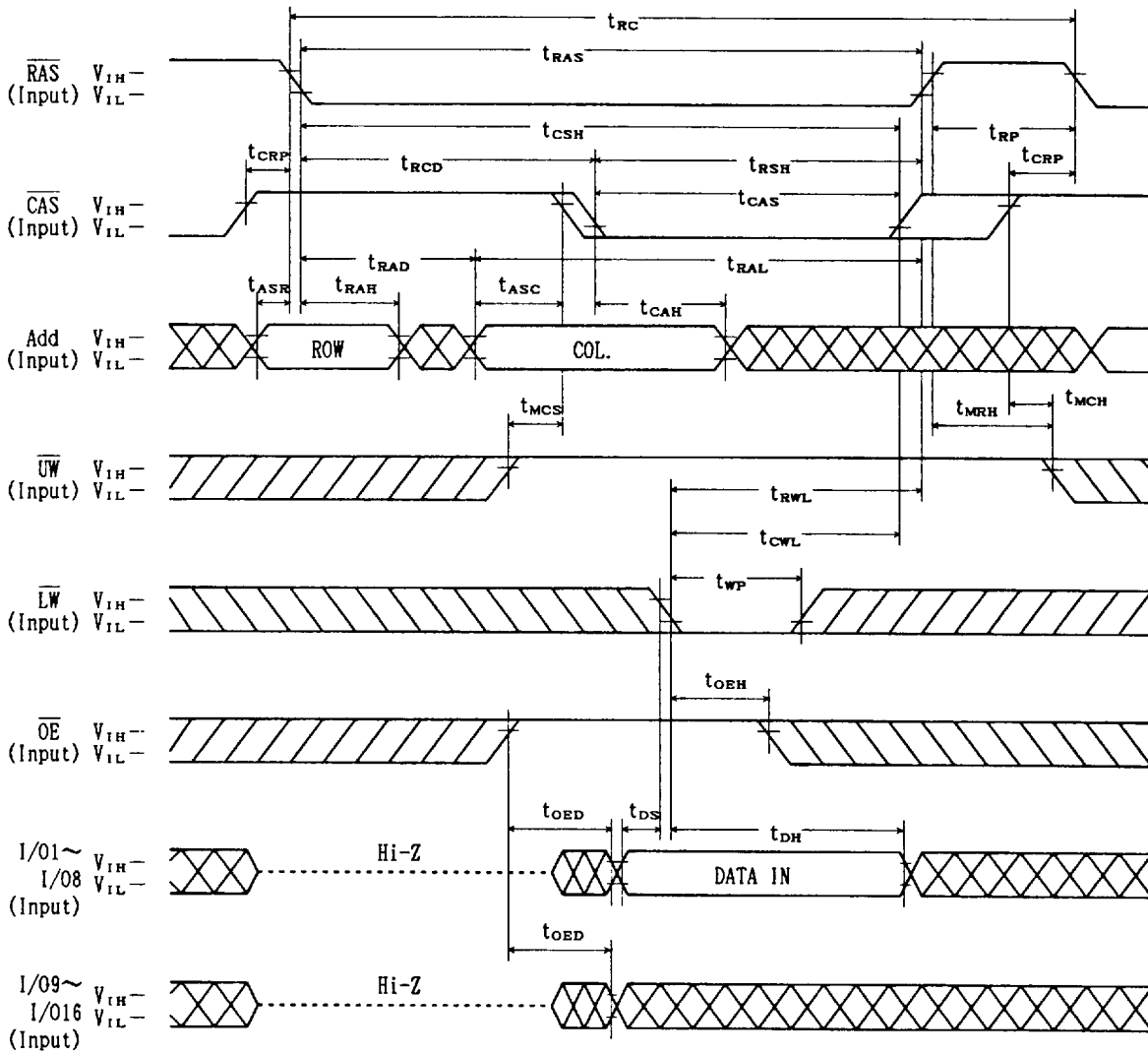

READ MODIFY WRITE CYCLE

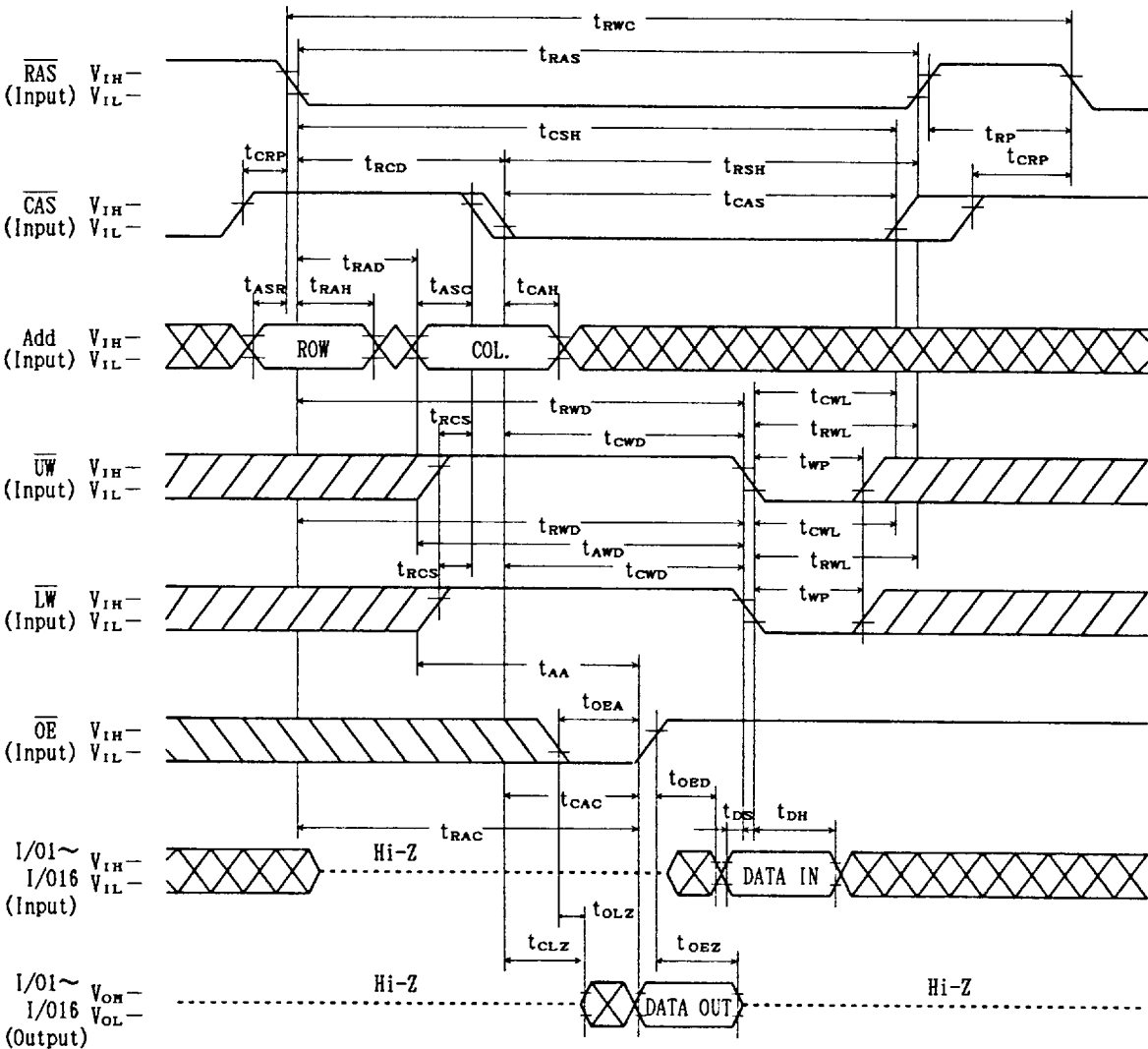

UPPER BYTE READ MODIFY WRITE CYCLE

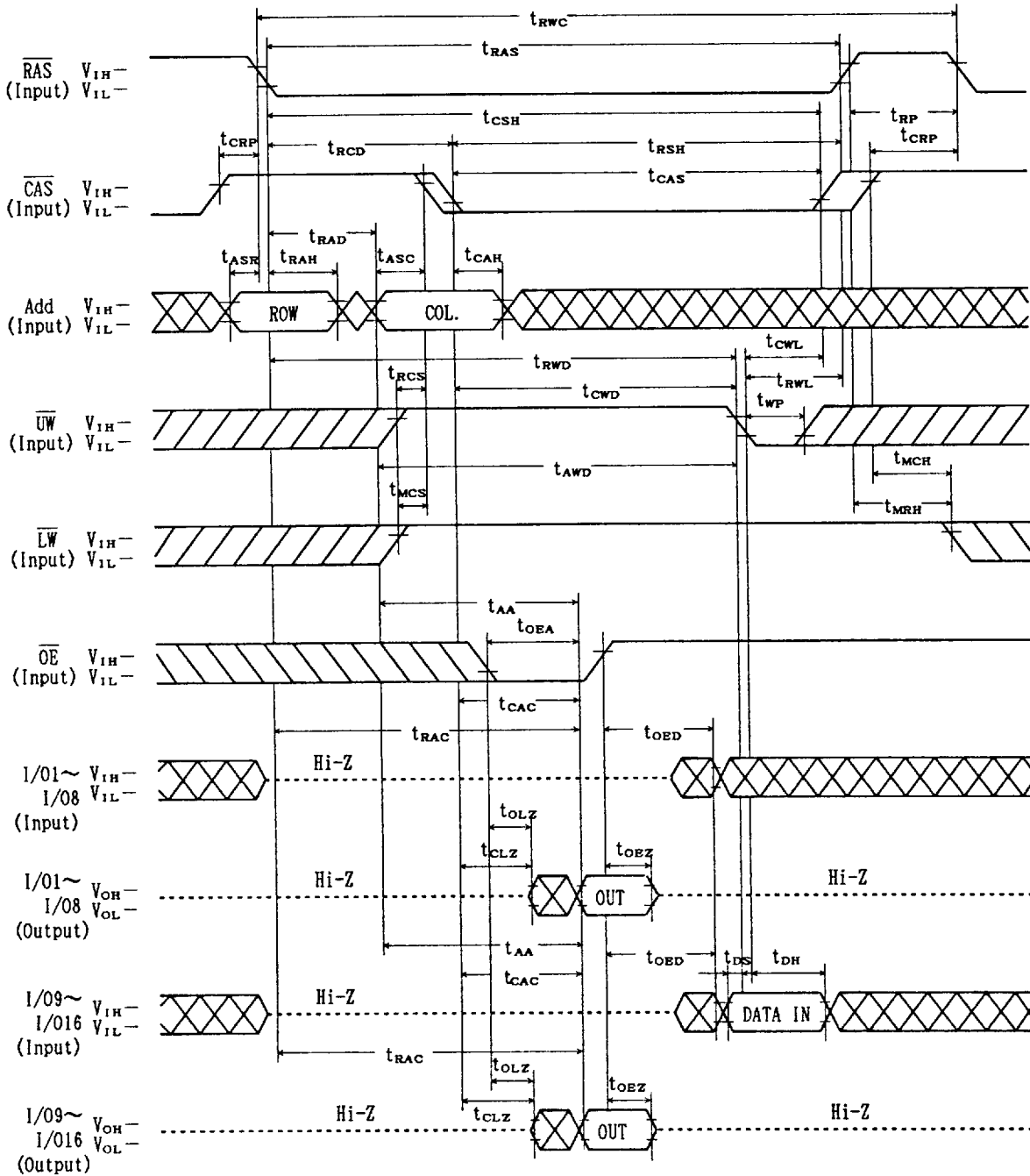

μ PD42S16170L, 42S17170L, 42S18170L

LOWER BYTE READ MODIFY WRITE CYCLE

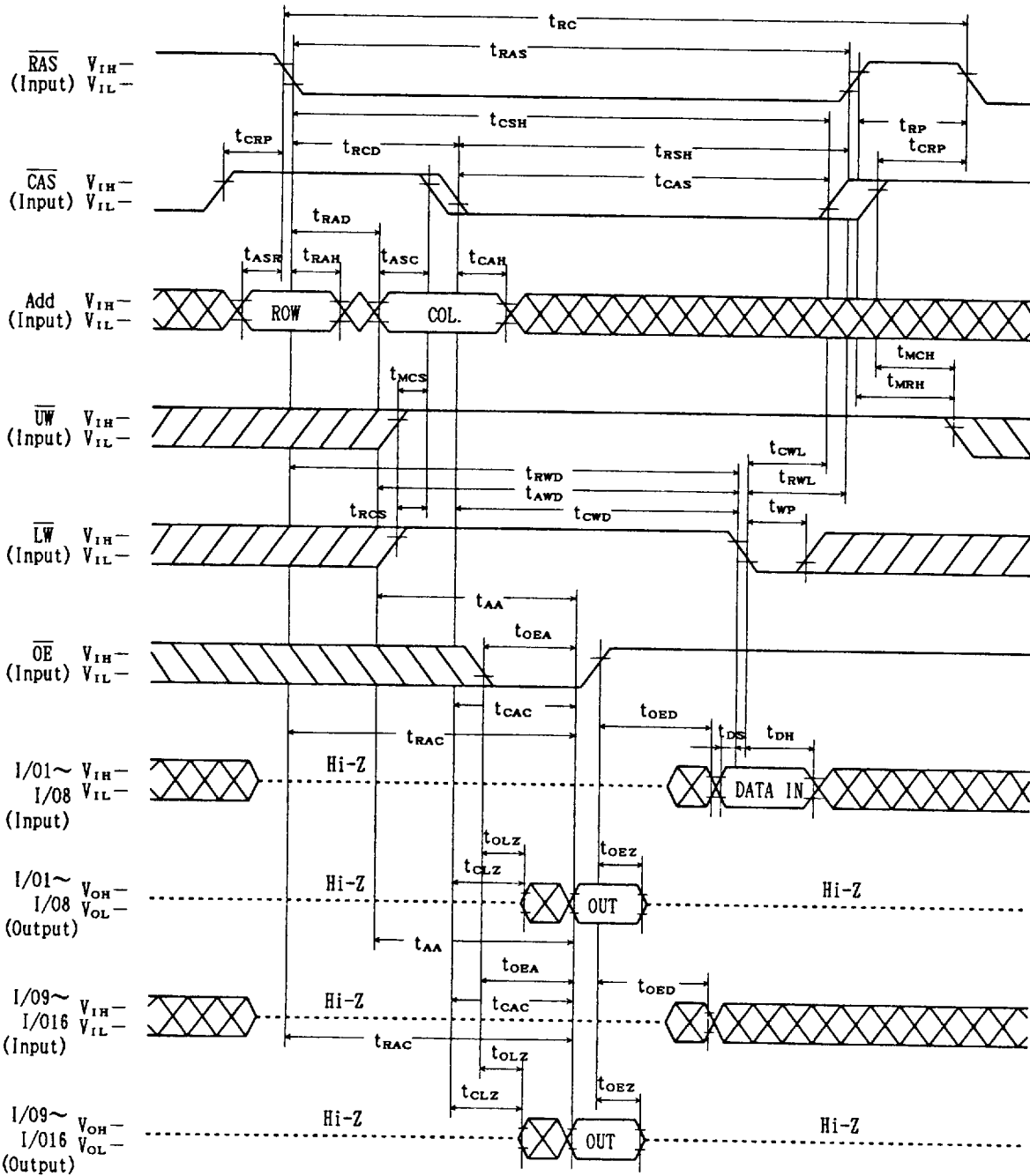

FAST PAGE MODE READ CYCLE

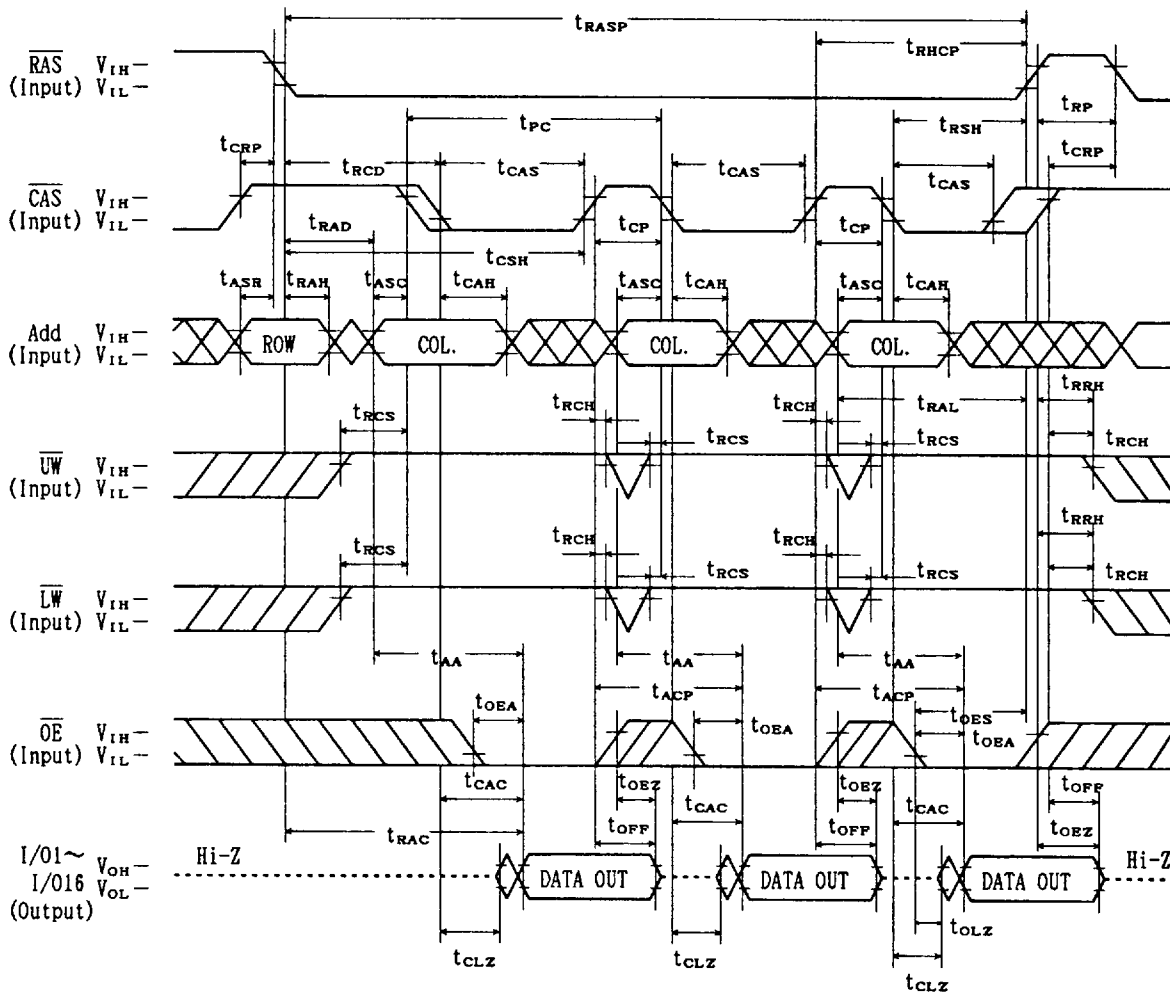

FAST PAGE MODE EARLY WRITE CYCLE

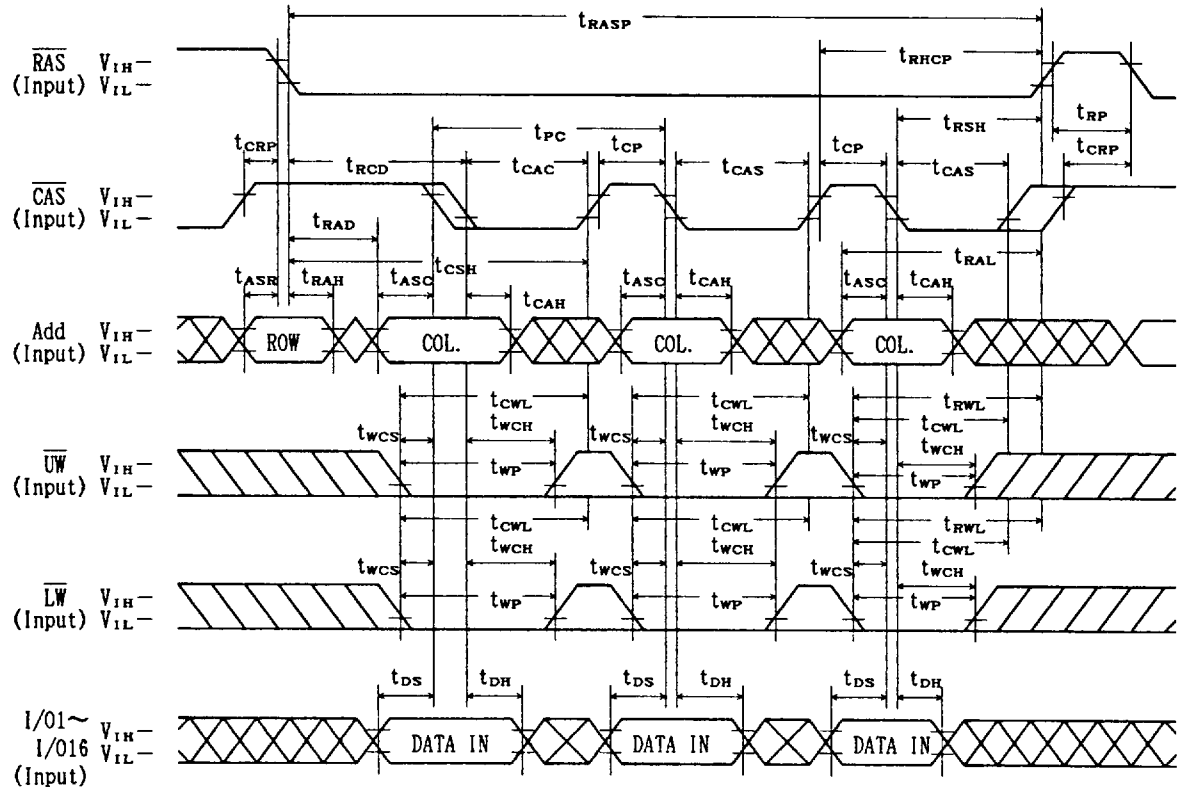

Note: \overline{OE} = Don't care

μPD42S16170L, 42S17170L, 42S18170L

FAST PAGE MODE UPPER BYTE EARLY WRITE CYCLE

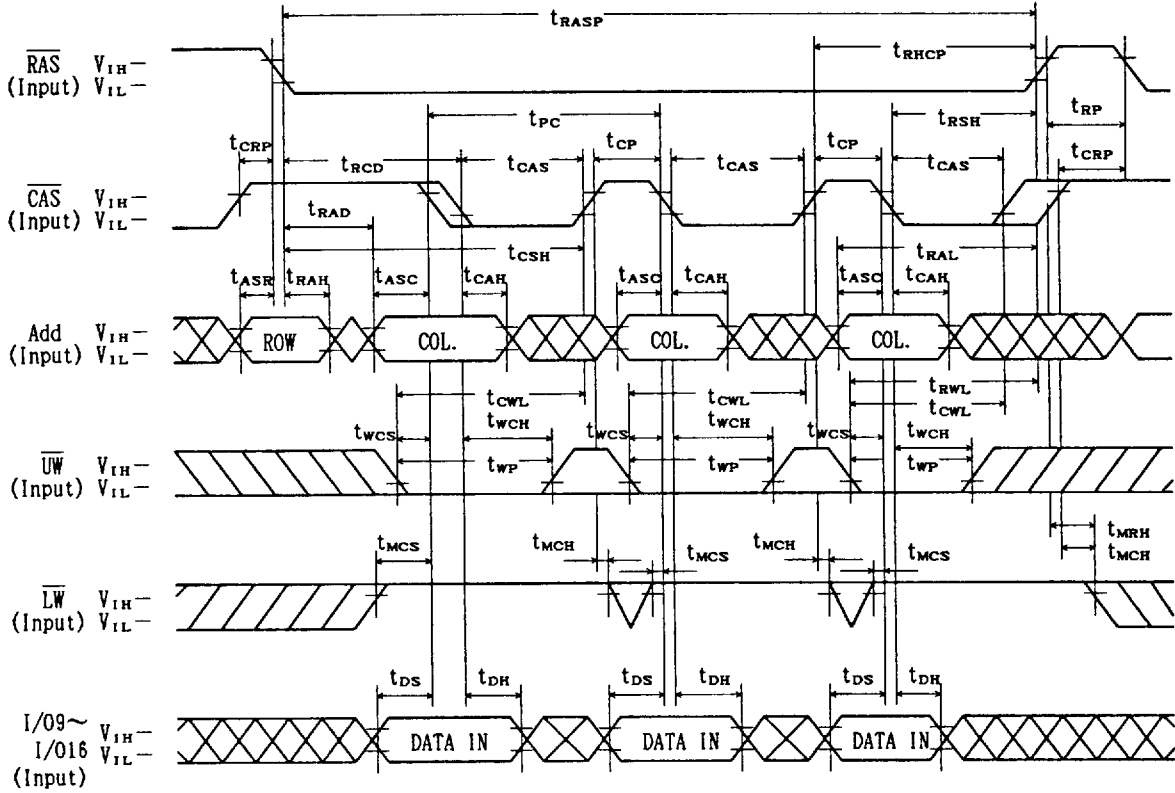

Note: $\overline{\text{OE}}$, I/01~I/08 = Don't care

μ PD42S16170L, 42S17170L, 42S18170L

FAST PAGE MODE LOWER BYTE EARLY WRITE CYCLE

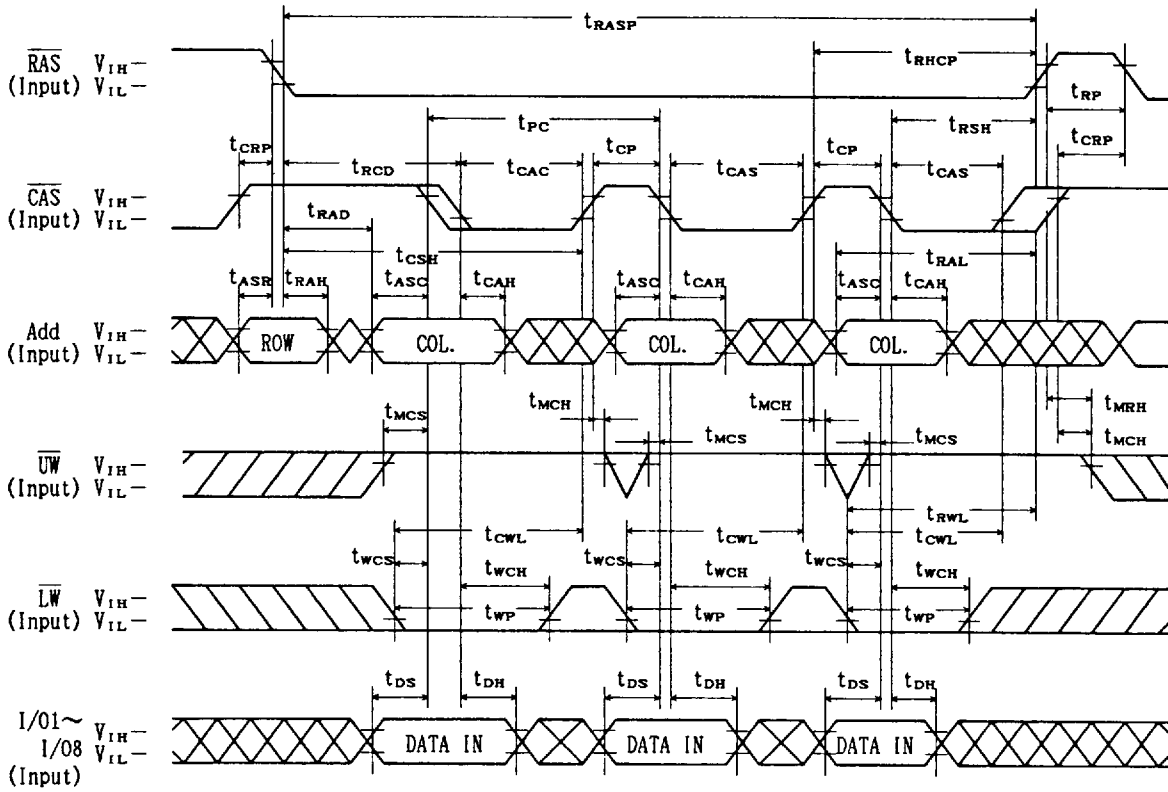

Note: \overline{OE} , I/09~I/016=Don't care

FAST PAGE MODE LATE WRITE CYCLE

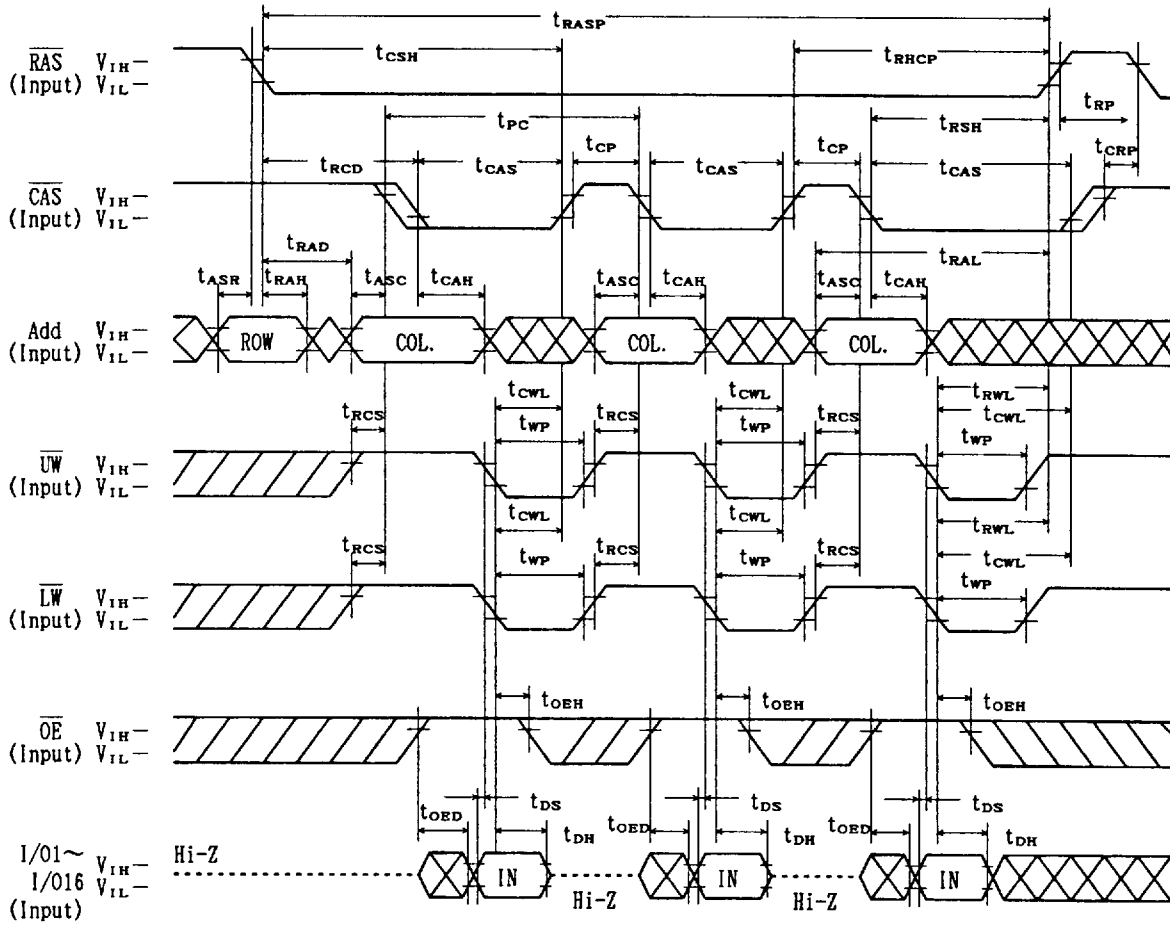

μ PD42S16170L, 42S17170L, 42S18170L

FAST PAGE MODE (UPPER BYTE LATE WRITE)

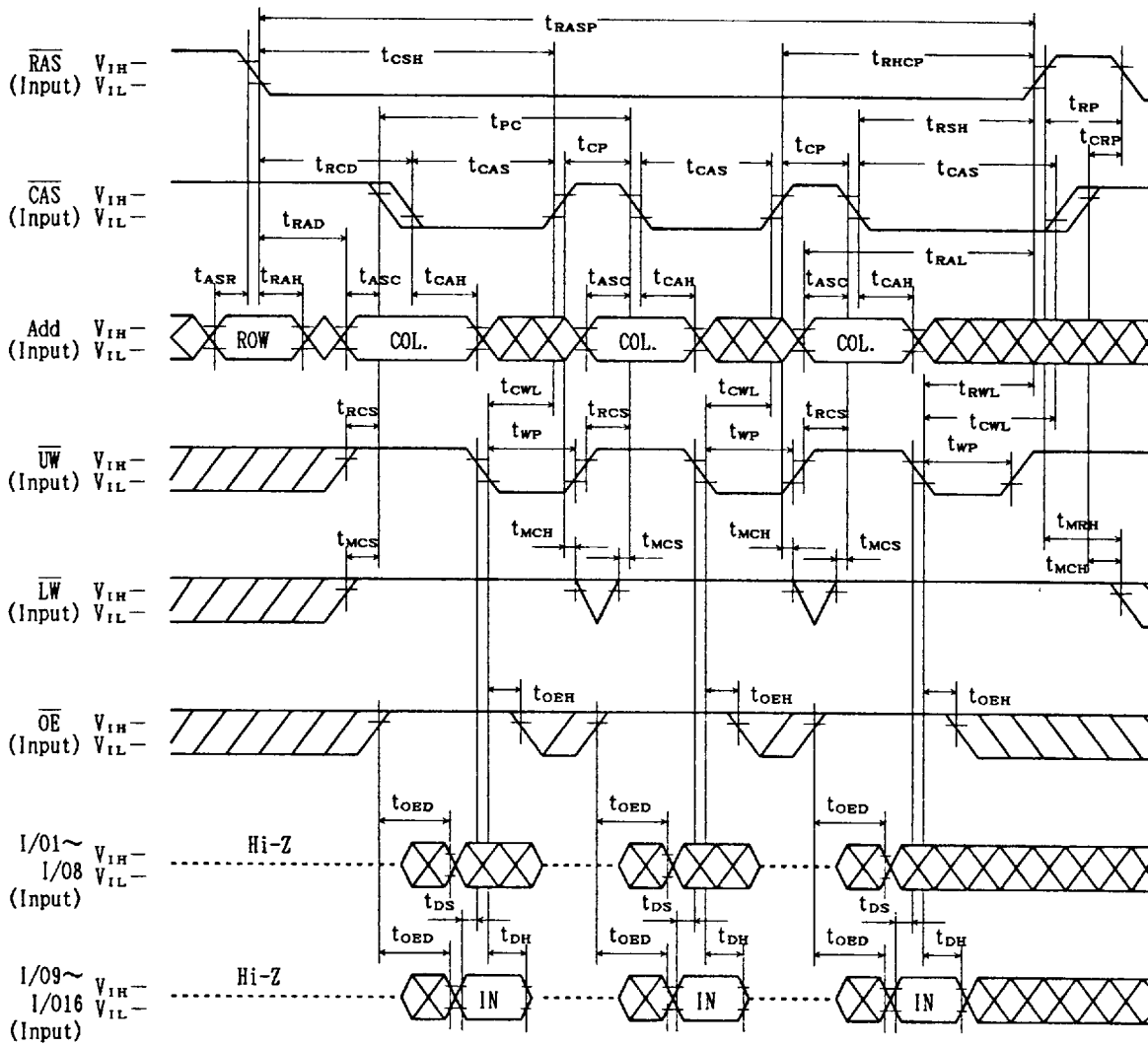

FAST PAGE MODE (LOWER BYTE LATE WRITE)

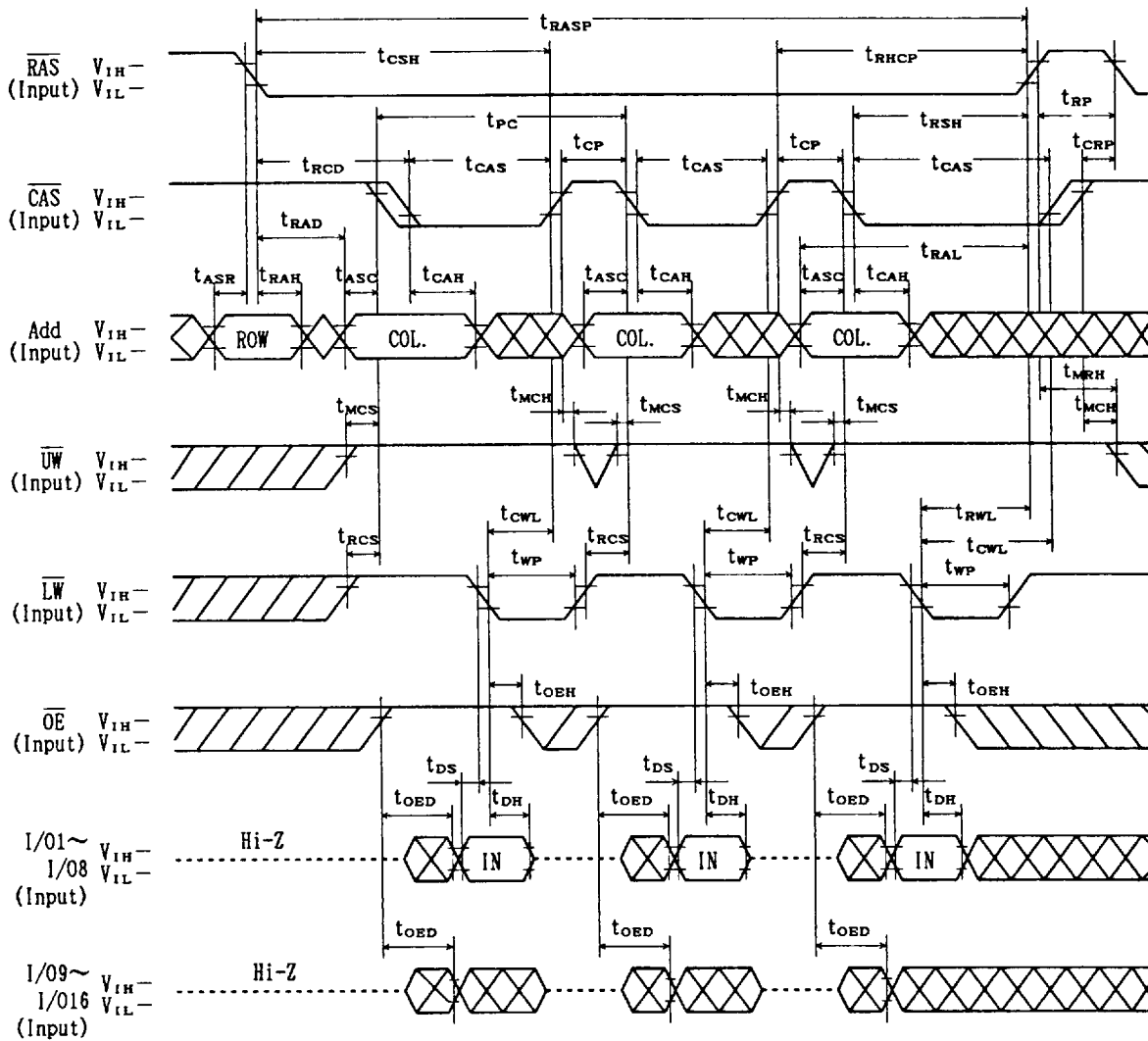

μPD42S16170L, 42S17170L, 42S18170L

FAST PAGE MODE READ MODIFY WRITE CYCLE

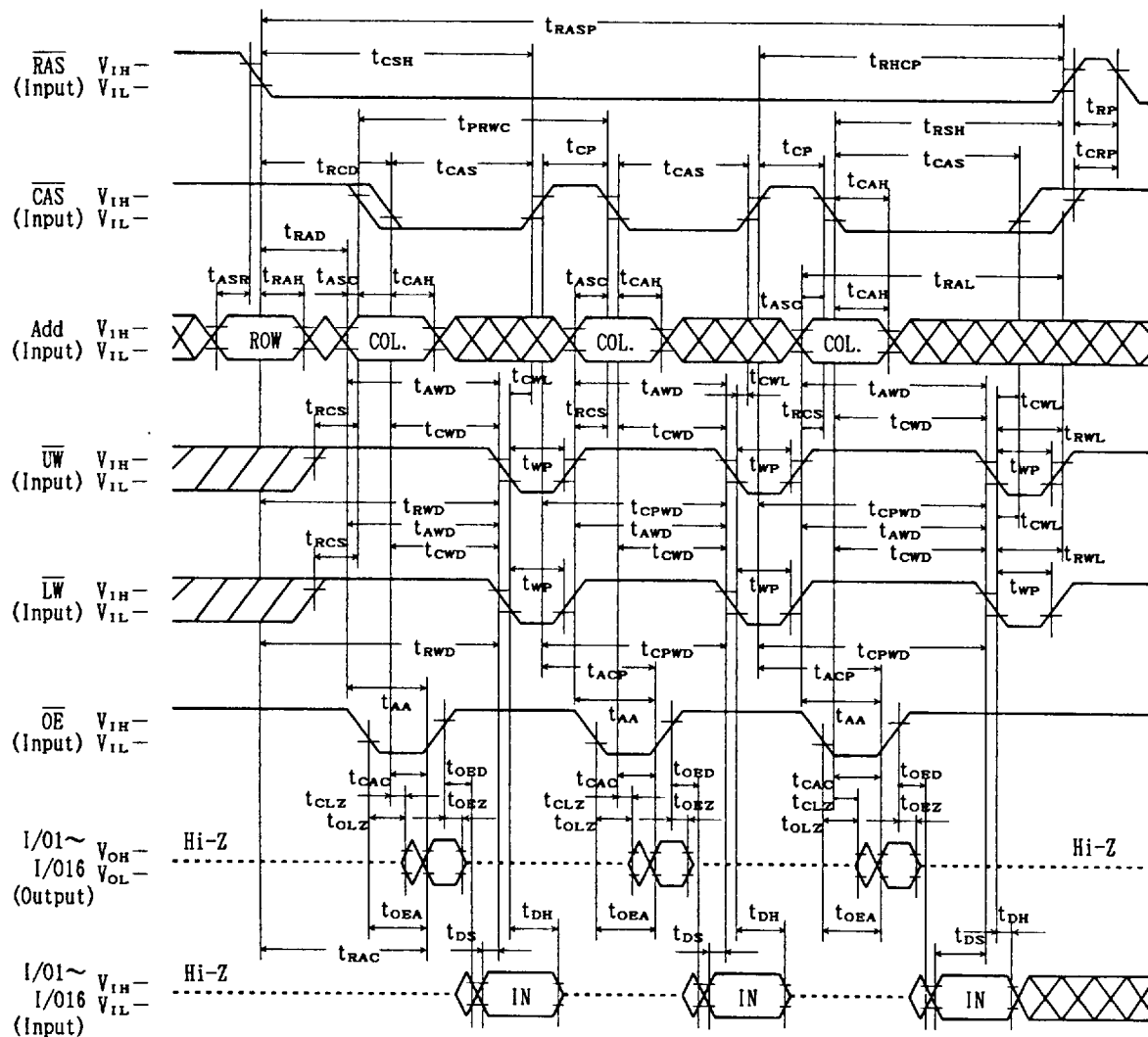

FAST PAGE MODE UPPER BYTE READ MODIFY WRITE CYCLE

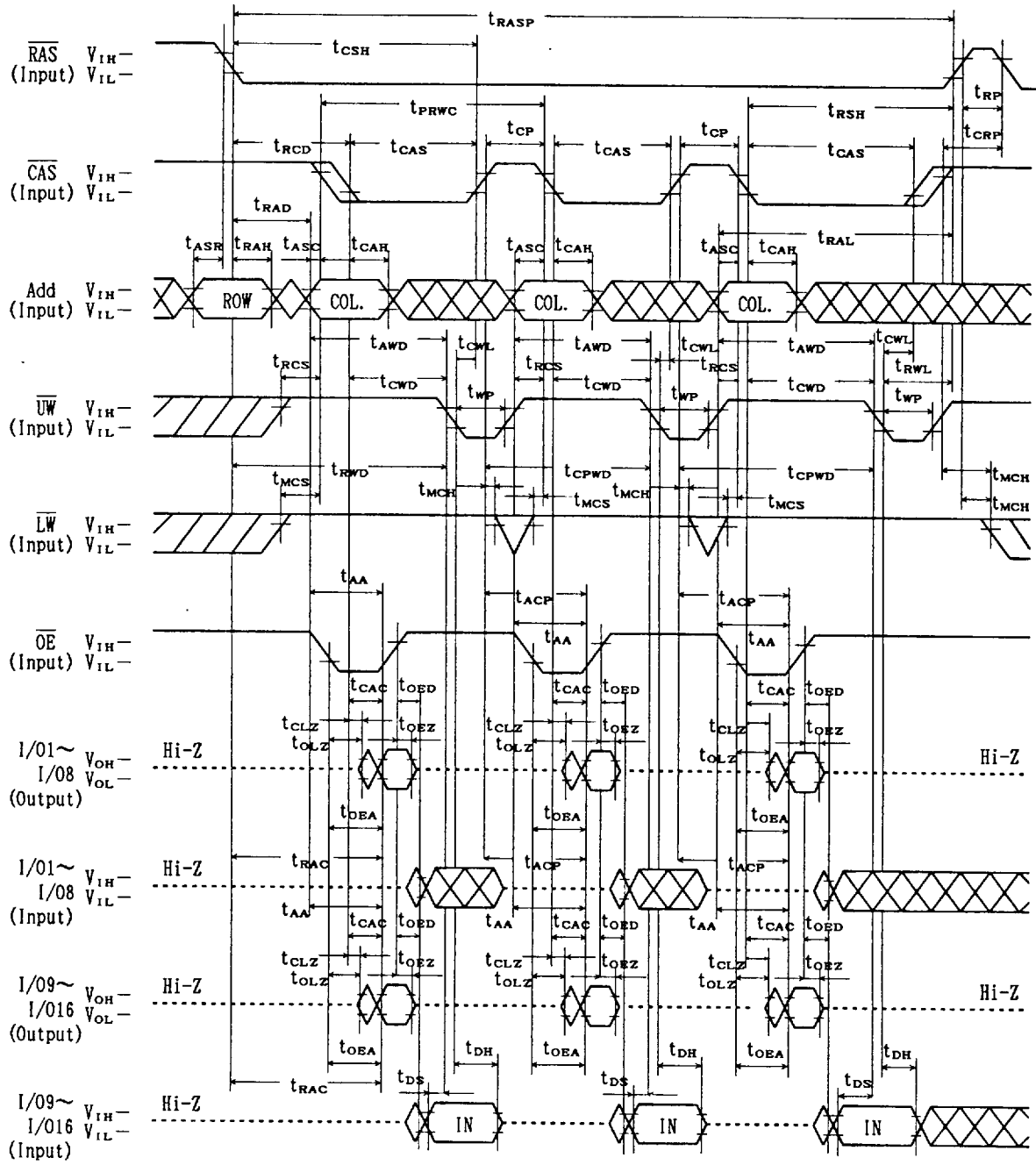

FAST PAGE MODE LOWER BYTE READ MODIFY WRITE CYCLE

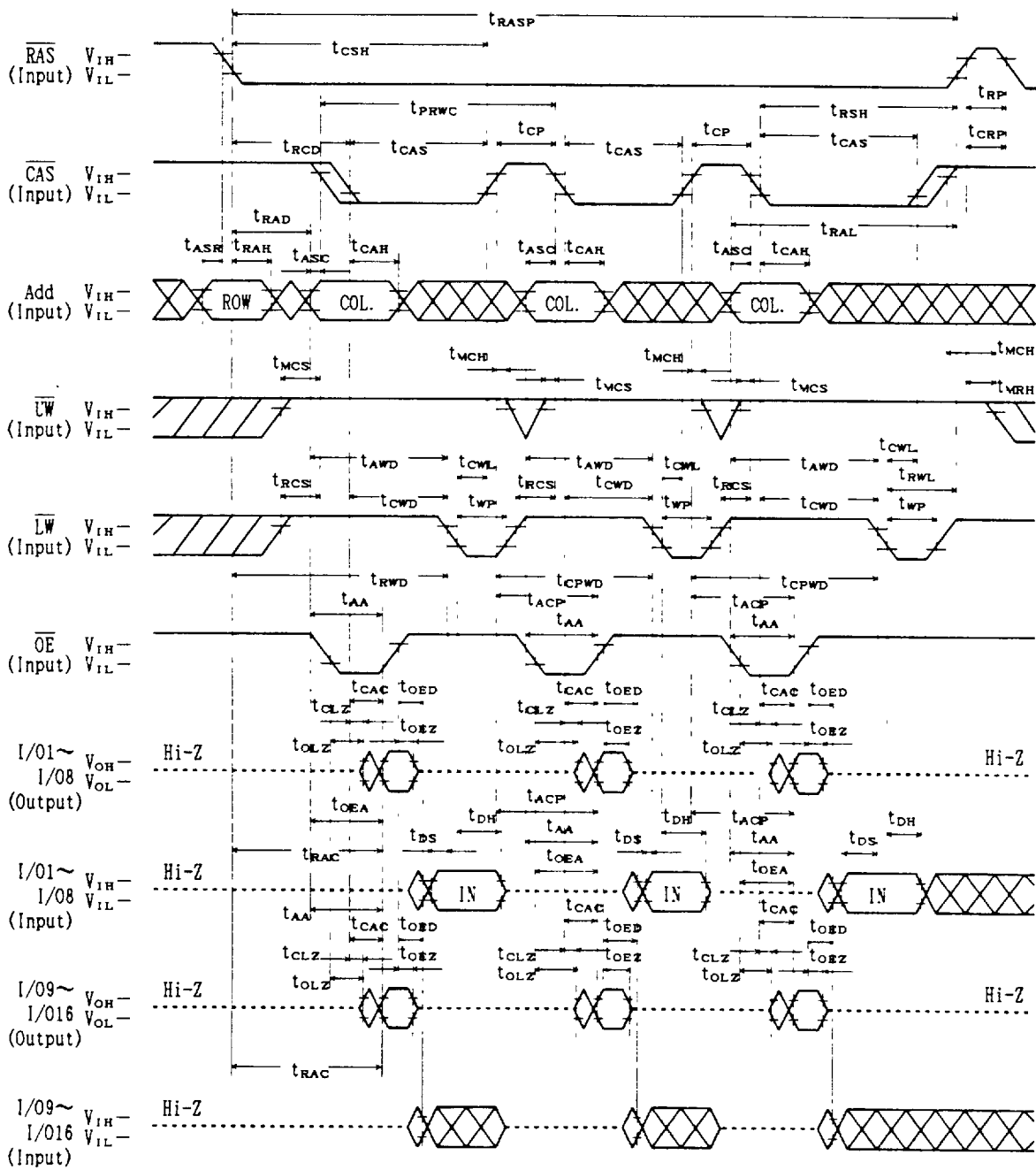

RAS ONLY REFRESH CYCLE

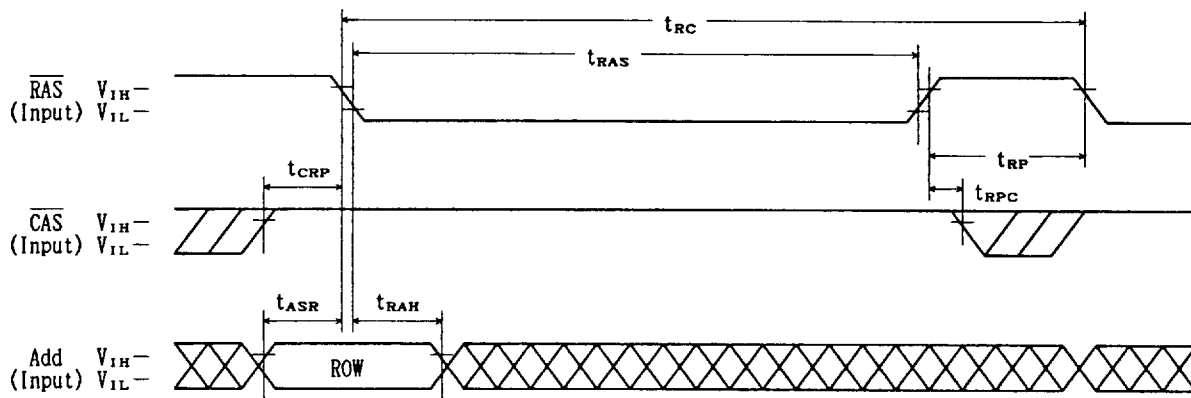

Note : I/01~I/016=Hi-Z

CAS BEFORE RAS REFRESH CYCLE

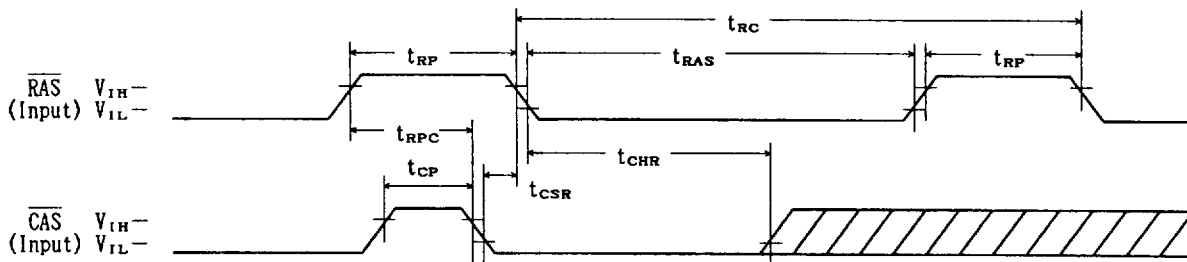

Note : Add=Don't care, I/01~I/016=Hi-Z

μ PD42S16170L, 42S17170L, 42S18170L

HIDDEN REFRESH CYCLE (READ)

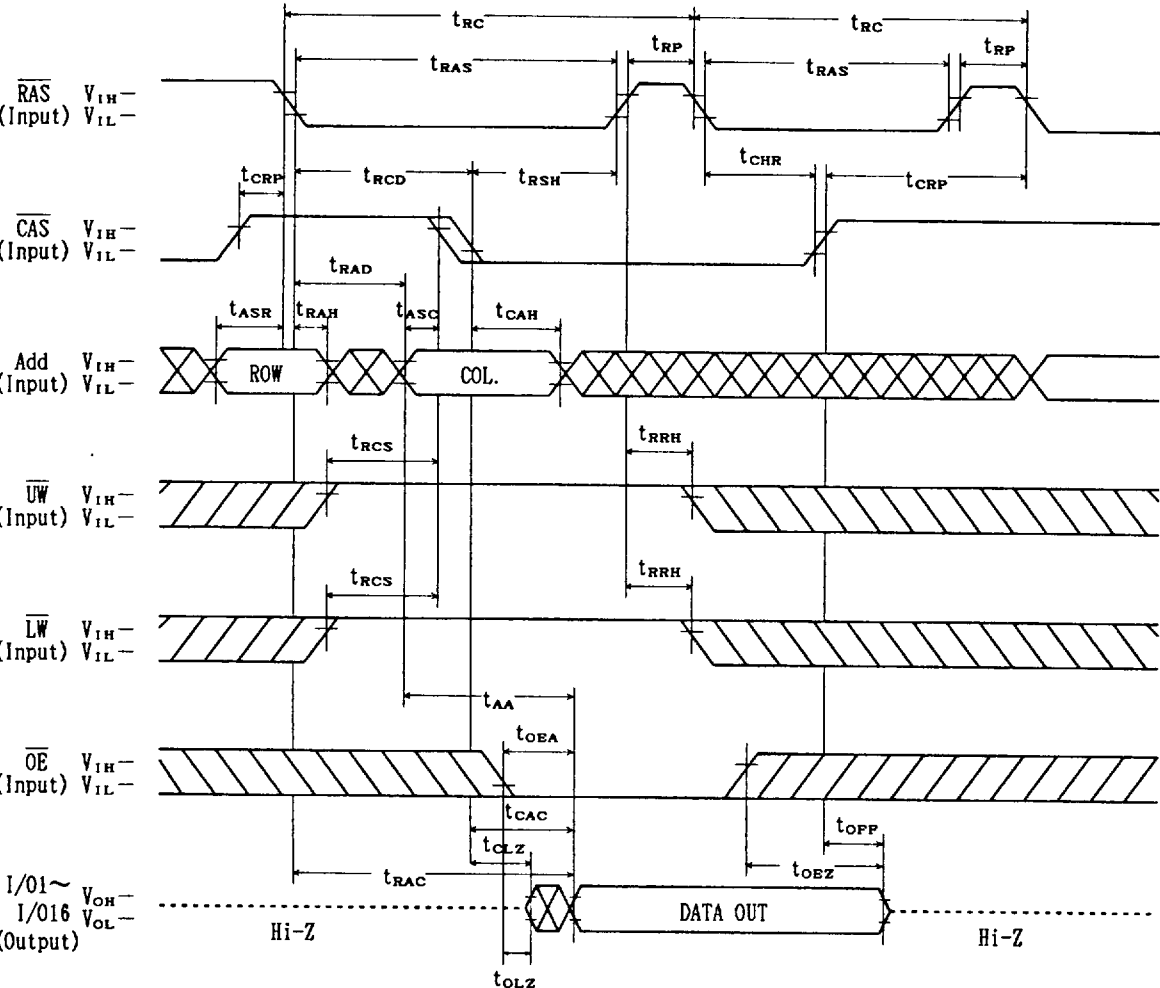

HIDDEN REFRESH CYCLE (WRITE)

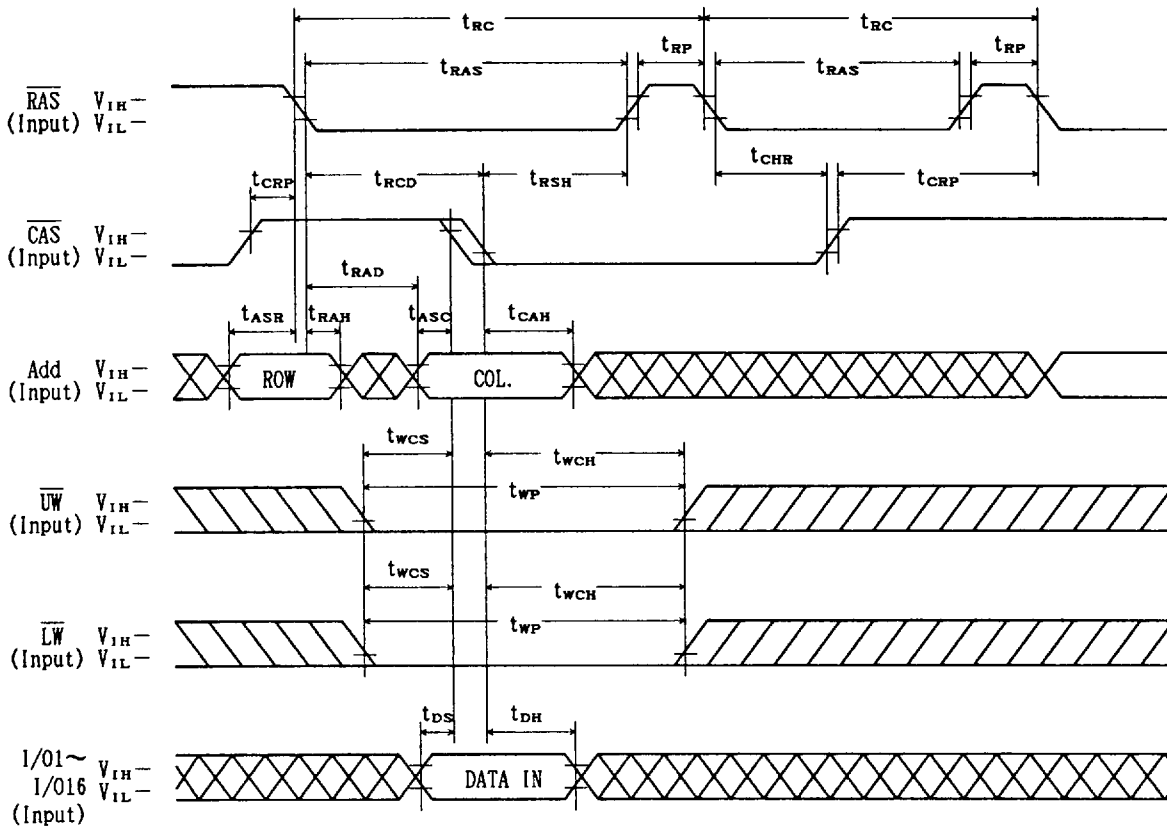

Note: \overline{OE} = Don't care

HIDDEN REFRESH CYCLE (UPPER BYTE WRITE)

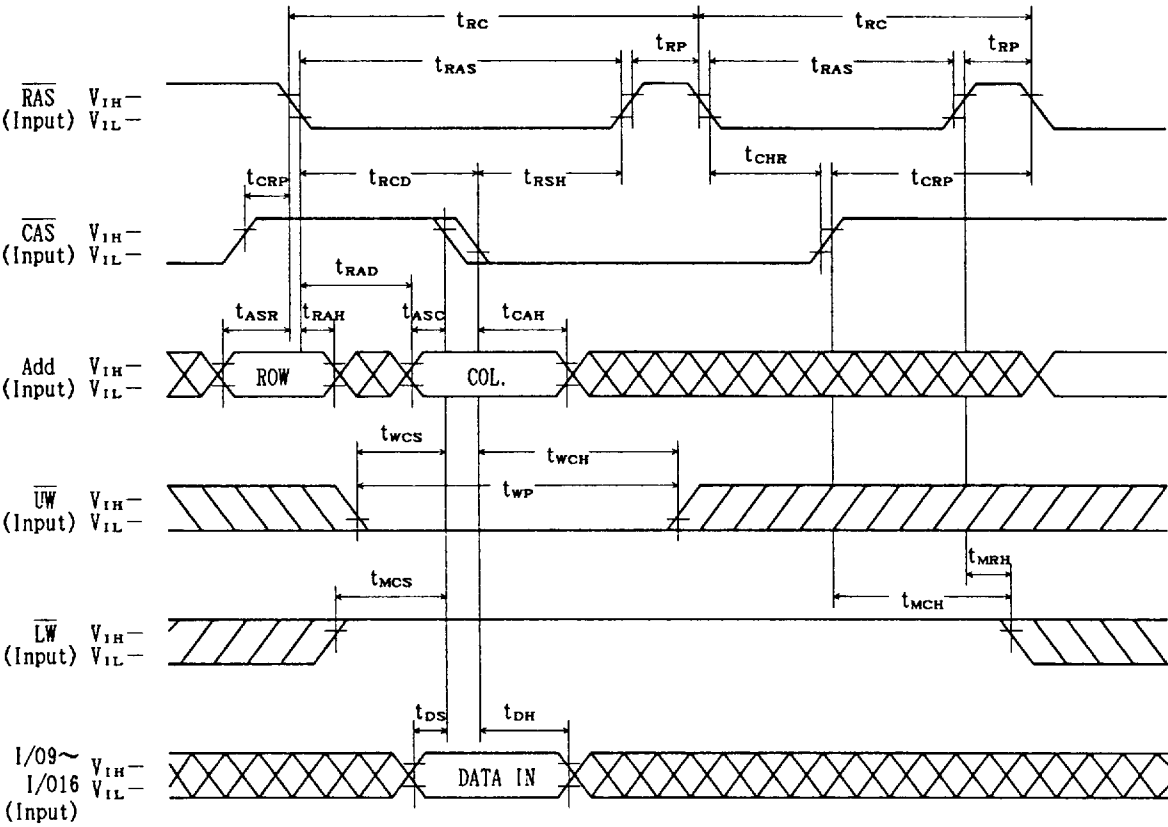

Note: \overline{OE} , I/01~I/08=Don't care

HIDDEN REFRESH CYCLE (LOWER BYTE WRITE)

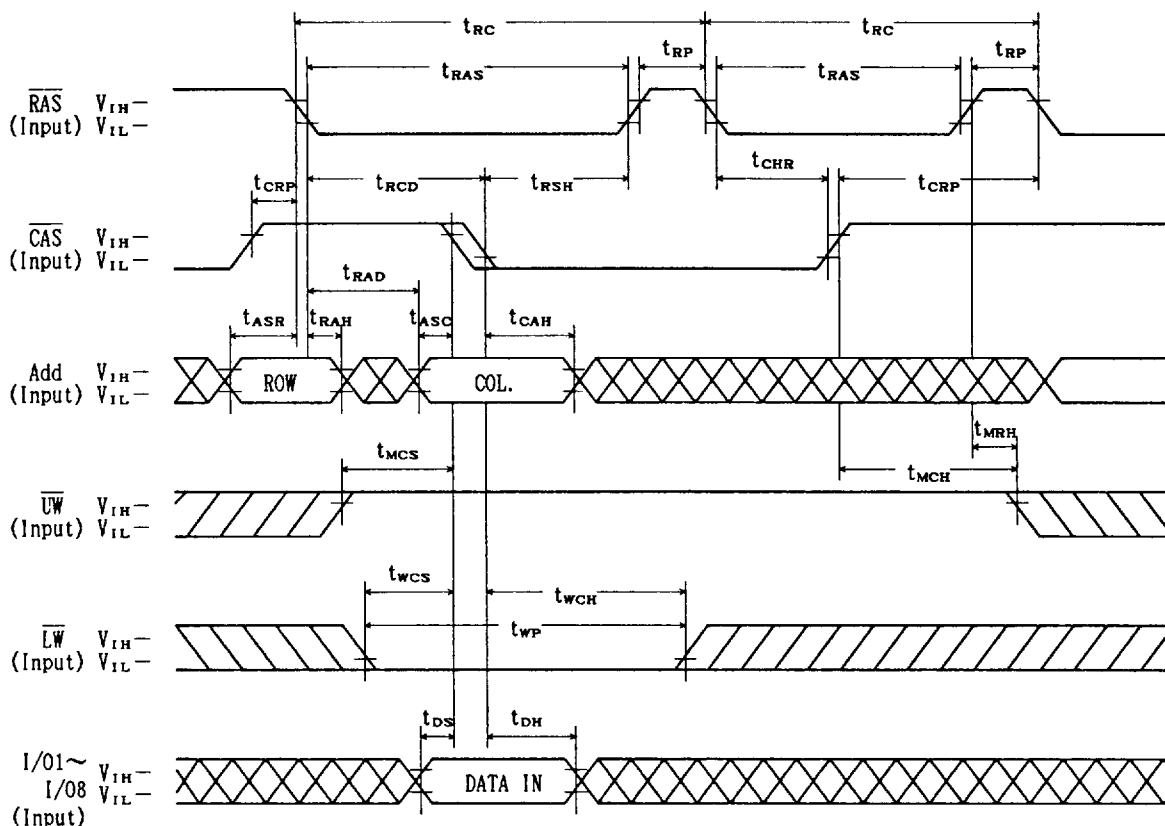

Note: \overline{OE} , I/09~I/016=Don't care

CAS BEFORE RAS SELF REFRESH CYCLE

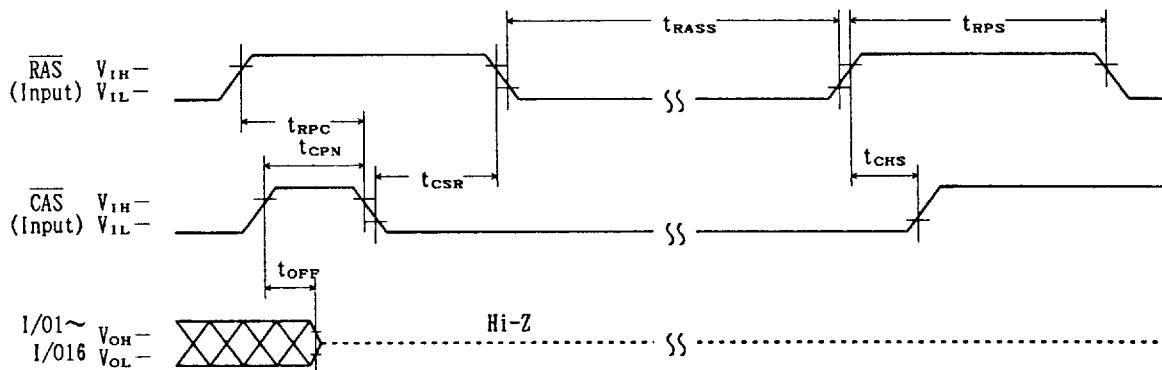

3. PACKAGE DRAWINGS

26 PIN PLASTIC SOJ (300mil)	24 Leads	495
28 PIN PLASTIC SOJ (400mil)	24 Leads	496
28 PIN PLASTIC SOJ (400mil)	28 Leads	497
32 PIN PLASTIC SOJ (400mil)		498
42 PIN PLASTIC SOJ (400mil)		499
26 PIN PLASTIC TSOP (300mil) *	24 Leads	500
26 PIN PLASTIC TSOP (300mil) *	24 Leads Reverse bent	501
28 PIN PLASTIC TSOP (400mil)	24 Leads	502
28 PIN PLASTIC TSOP (400mil)	24 Leads Reverse bent	503
28 PIN PLASTIC TSOP (400mil)	28 Leads	504
28 PIN PLASTIC TSOP (400mil)	28 Leads Reverse bent	505
32 PIN PLASTIC TSOP (400mil)		506
32 PIN PLASTIC TSOP (400mil)	Reverse bent	507
50 PIN PLASTIC TSOP (400mil)	44 Leads	508
50 PIN PLASTIC TSOP (400mil)	44 Leads Reverse bent	509
24 PIN PLASTIC ZIP (475mil)		510
28 PIN PLASTIC ZIP (475mil)		511
32 PIN PLASTIC ZIP (475mil)		512

* : under development

PAGE(S) INTENTIONALLY BLANK

494

26 PIN PLASTIC SOJ (300mil)
24 Leads

NEC Cord:S26LA-300A

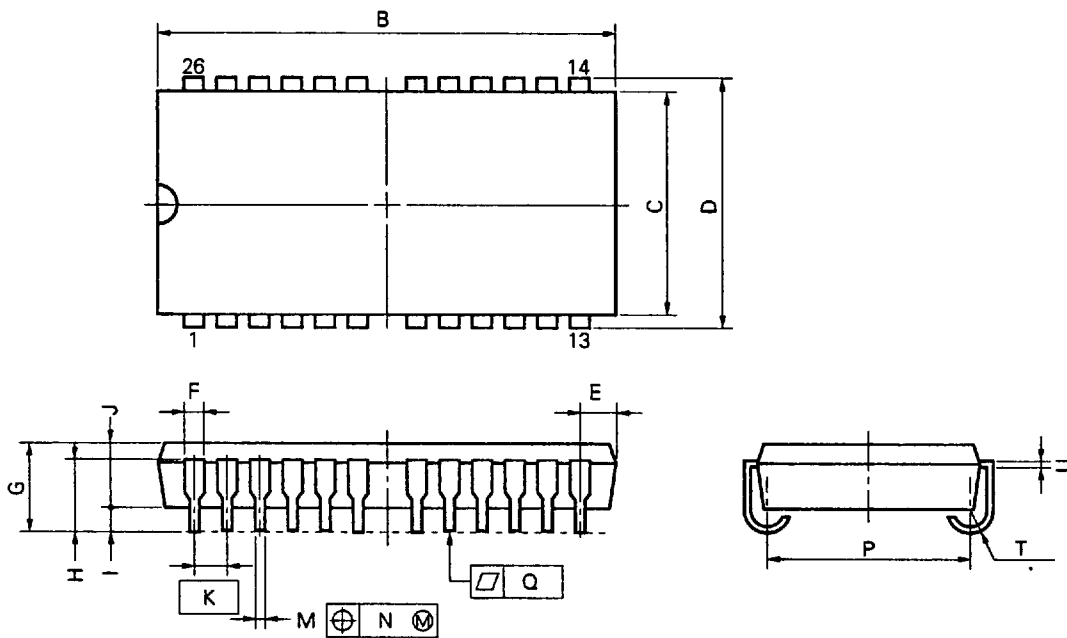

S26LA-300A

NOTE

Each lead centerline is located within 0.12 mm (0.005 inch) of its true position (T.P.) at maximum material condition.

ITEM	MILLIMETERS	INCHES
B	17.1 ^{+0.25} _{-0.05}	0.673 ^{+0.010} _{-0.002}
C	7.62	0.300
D	8.47±0.2	0.333 ^{+0.009} _{-0.008}
E	1.03±0.15	0.041 ^{+0.006} _{-0.007}
F	0.74	0.029
G	3.5±0.2	0.138±0.008
H	2.545±0.2	0.100±0.008
I	0.8 MIN.	0.031 MIN.
J	2.6	0.102
K	1.27 (T.P.)	0.050 (T.P.)
M	0.40±0.10	0.016 ^{+0.004} _{-0.005}
N	0.12	0.005
P	6.73±0.20	0.265±0.008
Q	0.10	0.004
T	R 0.85	R 0.033
U	0.20 ^{+0.10} _{-0.05}	0.008 ^{+0.004} _{-0.002}

28 PIN PLASTIC SOJ (400mil)
24 Leads

NEC Cord:P28LE-400A

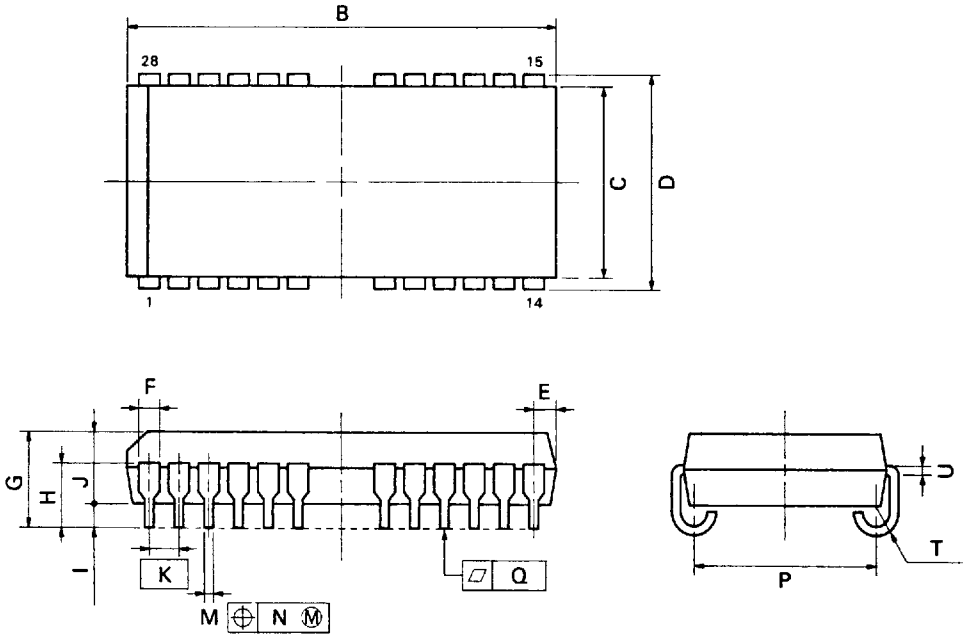

P28LE-400A

NOTE

Each lead centerline is located within 0.12 mm (0.005 inch) of its true position (T.P.) at maximum material condition.

ITEM	MILLIMETERS	INCHES
B	18.67 ^{+0.35}	0.735 ^{+0.013}
C	10.16	0.400
D	11.18 ^{+0.2}	0.440 ^{+0.008}
E	1.08 ^{+0.15}	0.043 ^{+0.006}
F	0.7	0.028
G	3.5 ^{+0.2}	0.138 ^{+0.008}
H	2.4 ^{+0.2}	0.094 ^{+0.008}
I	0.8 MIN.	0.031 MIN.
J	2.6	0.102
K	1.27 (T.P.)	0.050 (T.P.)
M	0.40 ^{+0.10}	0.016 ^{+0.004}
N	0.12	0.005
P	9.40 ^{+0.20}	0.370 ^{+0.008}
Q	0.15	0.006
T	R0.85	R0.033
U	0.20 ^{+0.08}	0.008 ^{+0.002}

28 PIN PLASTIC SOJ (400mil)
28 Leads

NEC Cord:P28LE-400A1

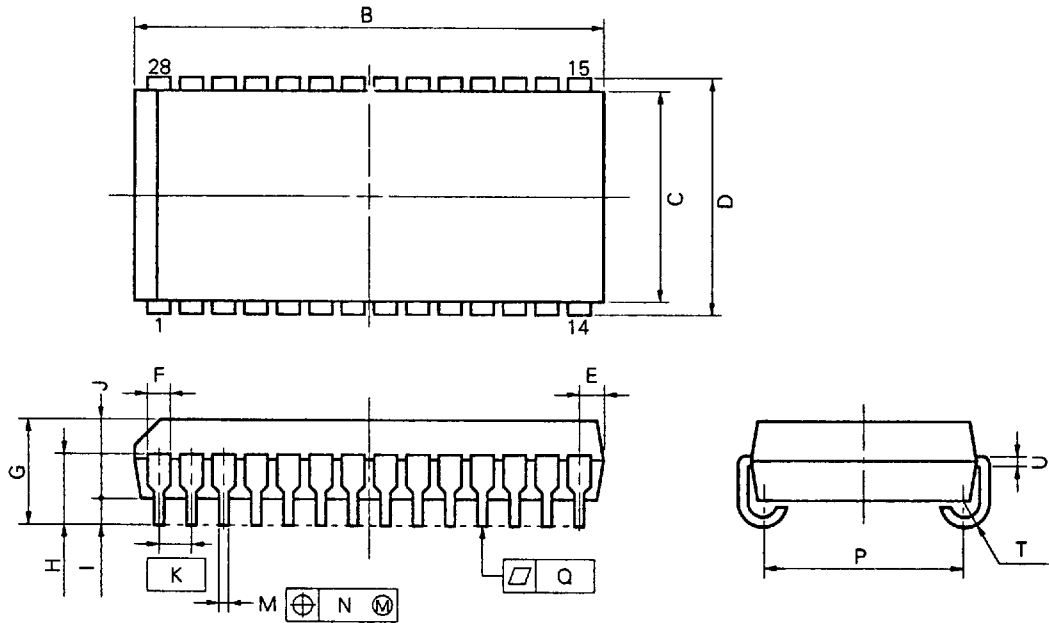

NOTE

Each lead centerline is located within 0.12 mm (0.005 inch) of its true position (T.P.) at maximum material condition.

P28LE-400A1

ITEM	MILLIMETERS	INCHES
B	18.67 ^{+0.2} _{-0.35}	0.735 ^{+0.008} _{-0.013}
C	10.16	0.400
D	11.18±0.2	0.440 ^{+0.008} _{-0.007}
E	1.08±0.15	0.043 ^{+0.006} _{-0.007}
F	0.74	0.029
G	3.5±0.2	0.138 ^{+0.008} _{-0.007}
H	2.545±0.2	0.100±0.008
I	0.8 MIN	0.031 MIN.
J	2.6	0.102
K	1.27 (T.P.)	0.050 (T.P.)
M	0.40±0.10	0.016 ^{+0.004} _{-0.005}
N	0.12	0.005
P	9.40±0.20	0.370 ^{+0.008} _{-0.007}
Q	0.10	0.004
T	R 0.85	R 0.033
U	0.20 ^{+0.10} _{-0.05}	0.008 ^{+0.004} _{-0.002}

32 PIN PLASTIC SOJ (400mil)

NEC Cord:P32LE-400A

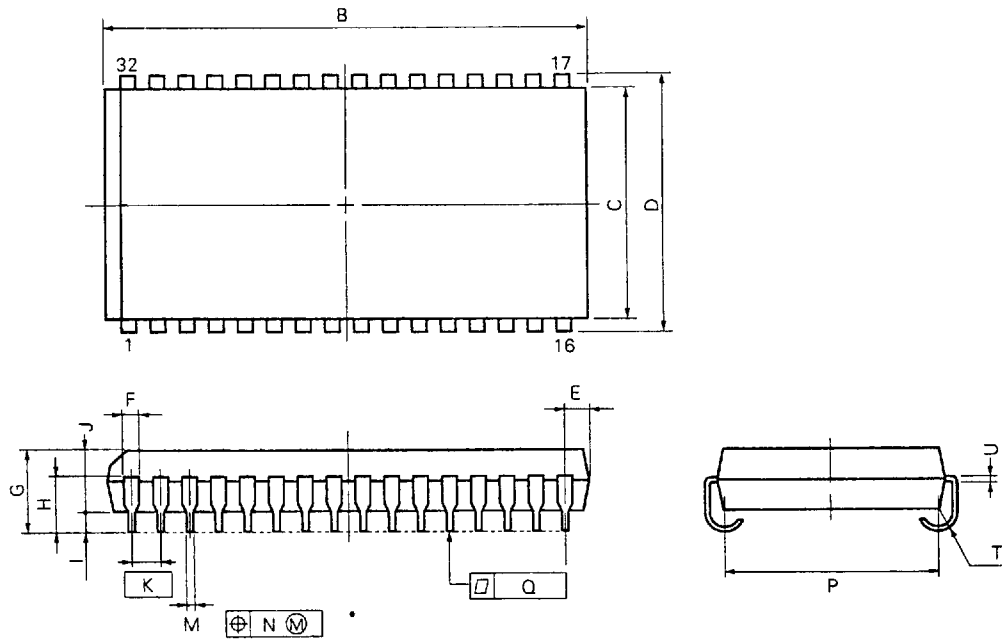

NOTE

Each lead centerline is located within 0.12 mm (0.005 inch) of its true position (T.P.) at maximum material condition

P32LE-400A

ITEM	MILLIMETERS	INCHES
B	21.06±0.2	0.829±0.008
C	10.16	0.400
D	11.18±0.2	0.440±0.008
E	1.005±0.1	0.040 ^{+0.004} _{-0.005}
F	0.74	0.029
G	3.5±0.2	0.138±0.008
H	2.545±0.2	0.100±0.008
I	0.8 MIN	0.031 MIN
J	2.6	0.102
K	1.27 (T.P.)	0.050 (T.P.)
M	0.40±0.10	0.016 ^{+0.004} _{-0.005}
N	0.12	0.005
P	9.4±0.20	0.370±0.008
Q	0.1	0.004
T	R 0.85	R 0.033
U	0.20 ^{+0.10} _{-0.02}	0.008 ^{+0.004} _{-0.002}

42 PIN PLASTIC SOJ (400mil)

NEC Cord: P42LE-400A

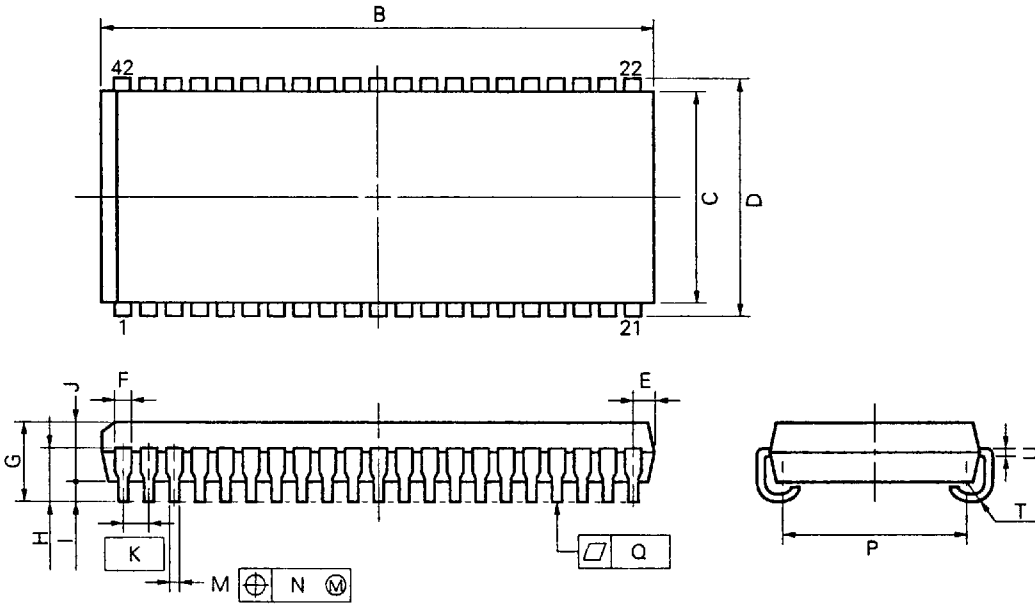

NOTE

Each lead centerline is located within 0.12 mm (0.005 inch) of its true position (T.P.) at maximum material condition.

P42LE-400A

ITEM	MILLIMETERS	INCHES
B	27.56 ^{+0.2} _{-0.35}	1.085 ^{+0.008} _{-0.014}
C	10.16	0.400
D	11.18±0.2	0.440±0.008
E	1.08±0.15	0.043 ^{+0.006} _{-0.007}
F	0.74	0.029
G	3.5±0.2	0.138±0.008
H	2.545±0.2	0.100±0.008
I	0.8 MIN.	0.031 MIN.
J	2.6	0.102
K	1.27 (T.P.)	0.050 (T.P.)
M	0.40±0.10	0.016 ^{+0.004} _{-0.005}
N	0.12	0.005
P	9.4±0.20	0.370±0.008
Q	0.10	0.004
T	R 0.85	R 0.033
U	0.20 ^{+0.10} _{-0.05}	0.008 ^{+0.004} _{-0.002}

26 PIN PLASTIC TSOP (300mil) *
24 Leads

* : under development

NEC Cord:S26G3-50-7JD

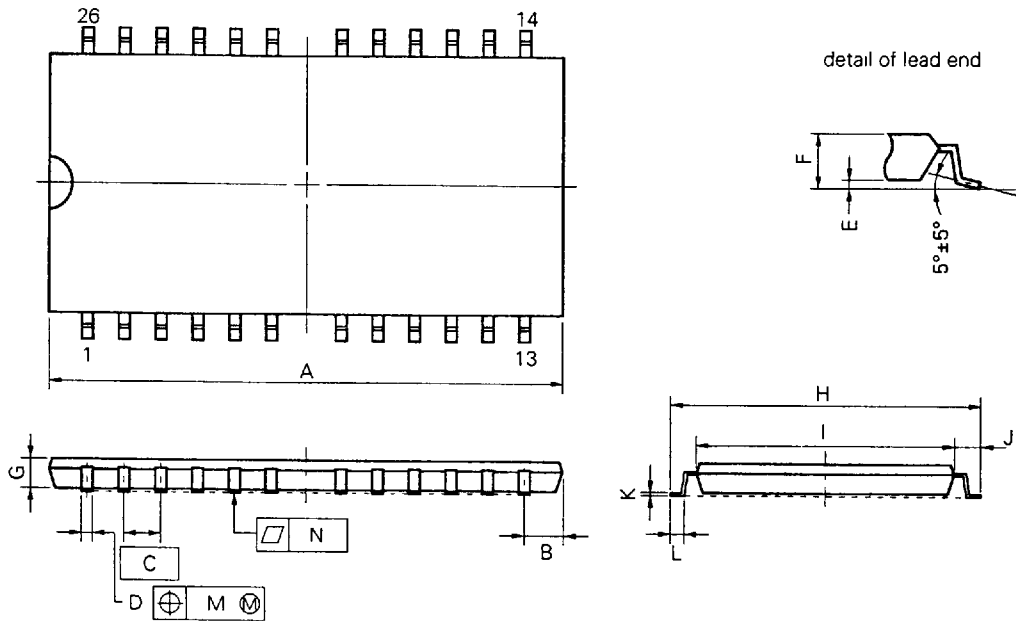

NOTE

Each lead centerline is located within 0.21 mm (0.009 inch) of its true position (T.P.) at maximum material condition.

S26G3-50-7JD

ITEM	MILLIMETERS	INCHES
A	17.40 MAX.	0.685 MAX.
B	1.06 MAX.	0.042 MAX.
C	1.27 (T.P.)	0.050 (T.P.)
D	0.40±0.10	0.016 ^{+0.004} / _{-0.005}
E	0.05±0.05	0.002±0.002
F	1.1 MAX.	0.044 MAX.
G	0.97	0.038
H	9.22±0.2	0.363±0.008
I	7.62±0.1	0.300±0.004
J	0.8±0.2	0.031 ^{+0.009} / _{-0.008}
K	0.125 ^{+0.10} / _{-0.05}	0.005 ^{+0.004} / _{-0.002}
L	0.5±0.1	0.020 ^{+0.004} / _{-0.005}
M	0.21	0.009
N	0.10	0.004

26 PIN PLASTIC TSOP (300mil) *
24 Leads Reverse bent

* : under development

NEC Cord:S26G3-50-7KD

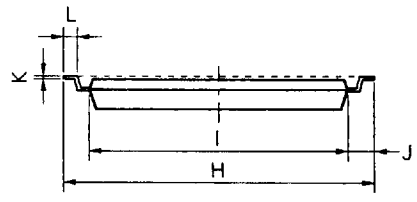
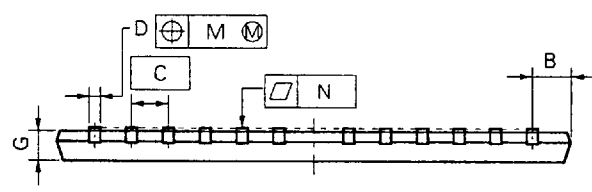
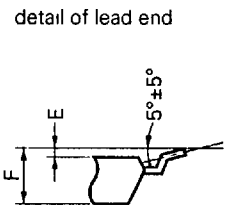
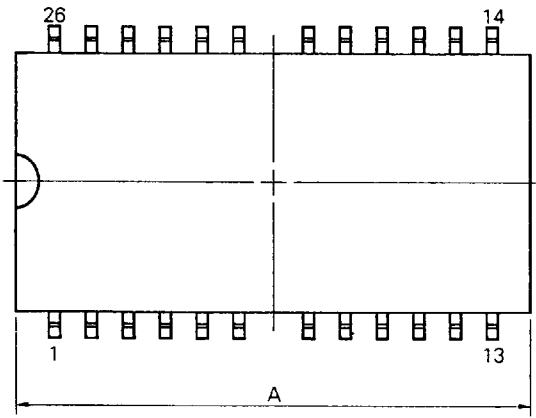

NOTE

Each lead centerline is located within 0.21 mm (0.009 inch) of its true position (T.P) at maximum material condition

S26G3-50-7KD

ITEM	MILLIMETERS	INCHES
A	17.40 MAX.	0.685 MAX.
B	1.06 MAX.	0.042 MAX.
C	1.27 (T.P.)	0.050 (T.P.)
D	0.40±0.10	0.016 ^{+0.004} / _{-0.005}
E	0.05±0.05	0.002±0.002
F	1.1 MAX.	0.044 MAX.
G	0.97	0.038
H	9.22±0.2	0.363±0.008
I	7.62±0.1	0.300±0.004
J	0.8±0.2	0.031 ^{+0.009} / _{-0.008}
K	0.125 ^{+0.10} / _{-0.05}	0.005 ^{+0.004} / _{-0.002}
L	0.5±0.1	0.020 ^{+0.004} / _{-0.005}
M	0.21	0.009
N	0.10	0.004

28 PIN PLASTIC TSOP (400mil)
24 Leads

NEC Cord:S28G5-50-7JD1

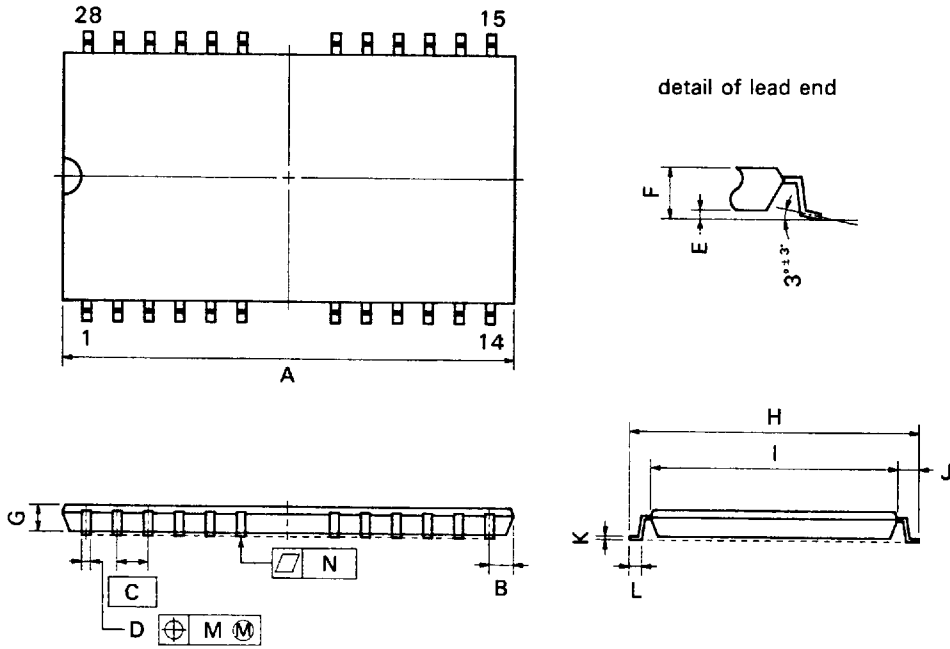

NOTE

Each lead centerline is located within 0.21 mm (0.009 inch) of its true position (T.P.) at maximum material condition.

S28G5-50-7JD1

ITEM	MILLIMETERS	INCHES
A	18.81 MAX.	0.741 MAX.
B	1.15 MAX.	0.046 MAX.
C	1.27 (T.P.)	0.050 (T.P.)
D	0.40 ^{+0.10}	0.016 ^{+0.004}
E	0.05 ^{+0.05}	0.002 ^{+0.002}
F	1.1 MAX.	0.044 MAX.
G	0.97	0.038
H	11.76 ^{+0.2}	0.463 ^{+0.008}
I	10.16 ^{+0.1}	0.400 ^{+0.004}
J	0.8 ^{+0.2}	0.031 ^{+0.008}
K	0.125 ^{+0.10}	0.005 ^{+0.004}
L	0.5 ^{+0.1}	0.020 ^{+0.004}
M	0.21	0.009
N	0.10	0.004

28 PIN PLASTIC TSOP (400mil)
24 Leads Reverse bent

NEC Cord:S28G5-50-7KD1

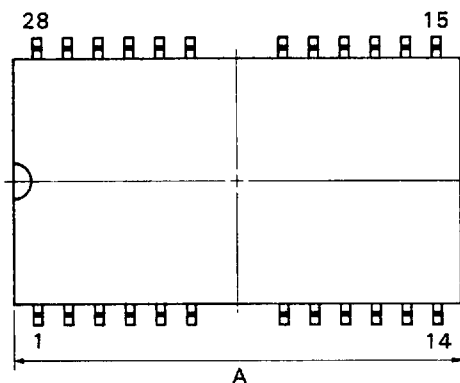

detail of lead end

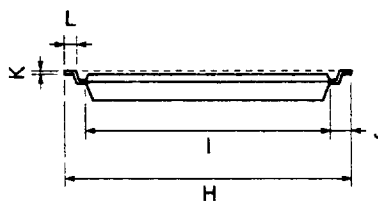
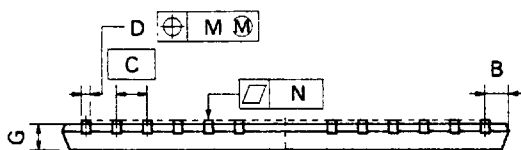
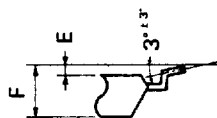

S28G5-50-7KD1

NOTE

Each lead centerline is located within 0.21 mm (0.009 inch) of its true position (T.P.) at maximum material condition.

ITEM	MILLIMETERS	INCHES
A	18.81 MAX.	0.741 MAX.
B	1.15 MAX.	0.046 MAX.
C	1.27 (T.P.)	0.050 (T.P.)
D	0.40 ^{+0.10}	0.016 ^{-0.005}
E	0.05 ^{+0.05}	0.002 ^{+0.002}
F	1.1 MAX.	0.044 MAX.
G	0.97	0.038
H	11.76 ^{+0.2}	0.463 ^{+0.008}
I	10.16 ^{+0.1}	0.400 ^{+0.004}
J	0.8 ^{+0.2}	0.031 ^{-0.008}
K	0.125 ^{-0.018}	0.005 ^{-0.002}
L	0.5 ^{+0.1}	0.020 ^{-0.005}
M	0.21	0.009
N	0.10	0.004

28 PIN PLASTIC TSOP (400mil)
28 Leads

NEC Cord:S28G5-50-7JD2

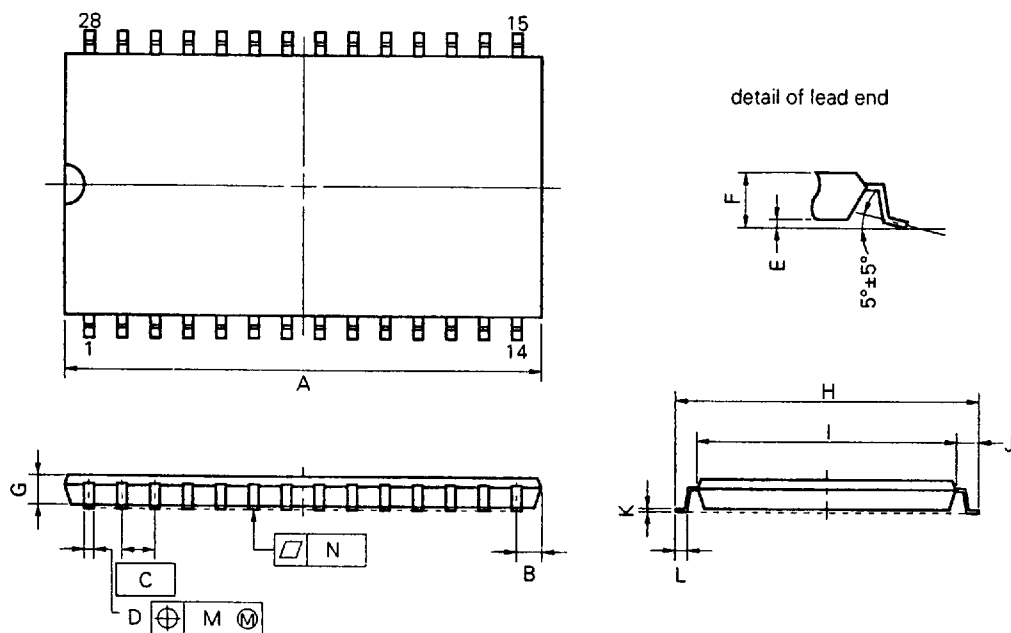

NOTE

Each lead centerline is located within 0.21 mm (0.009 inch) of its true position (T.P.) at maximum material condition.

S28G5-50-7JD2

ITEM	MILLIMETERS	INCHES
A	18.81 MAX.	0.741 MAX.
B	1.15 MAX.	0.046 MAX.
C	1.27 (T.P.)	0.050 (T.P.)
D	0.40±0.10	0.016 ^{+0.004} _{-0.005}
E	0.05±0.05	0.002±0.002
F	1.1 MAX.	0.044 MAX.
G	0.97	0.038
H	11.76±0.2	0.463±0.008
I	10.16±0.1	0.400±0.004
J	0.8±0.2	0.031 ^{+0.009} _{-0.008}
K	0.125 ^{+0.10} _{-0.05}	0.005 ^{+0.004} _{-0.002}
L	0.5±0.15	0.020 ^{+0.006} _{-0.007}
M	0.21	0.009
N	0.10	0.004

28 PIN PLASTIC TSOP (400mil)
28 Leads Reverse bent

NEC Cord:S28G5-50-7KD2

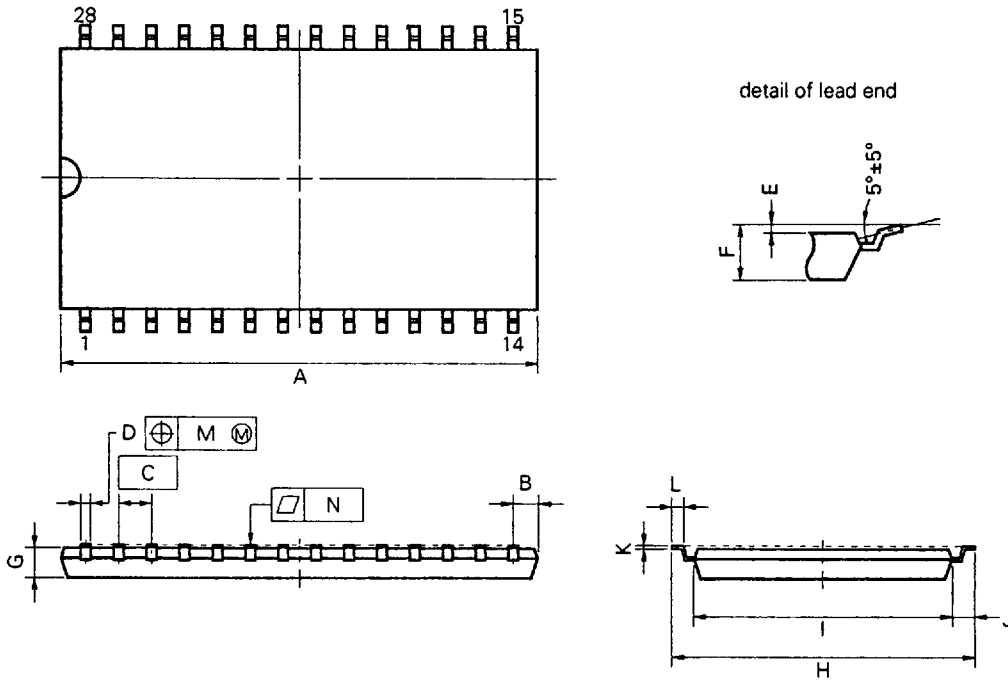

NOTE

Each lead centerline is located within 0.21 mm (0.009 inch) of its true position (T.P.) at maximum material condition.

S28G5-50-7KD2

ITEM	MILLIMETERS	INCHES
A	18.81 MAX.	0.741 MAX.
B	1.15 MAX.	0.046 MAX.
C	1.27 (T.P.)	0.050 (T.P.)
D	0.40±0.10	0.016 ^{+0.004} _{-0.005}
E	0.05±0.05	0.002±0.002
F	1.1 MAX.	0.044 MAX.
G	0.97	0.038
H	11.76±0.2	0.463±0.008
I	10.16±0.1	0.400±0.004
J	0.8±0.2	0.031 ^{+0.009} _{-0.008}
K	0.125 ^{+0.10} _{-0.05}	0.005 ^{+0.004} _{-0.002}
L	0.5±0.15	0.020 ^{+0.006} _{-0.007}
M	0.21	0.009
N	0.10	0.004

32 PIN PLASTIC TSOP (400mil)

NEC Cord:S32G5-50-7JD1

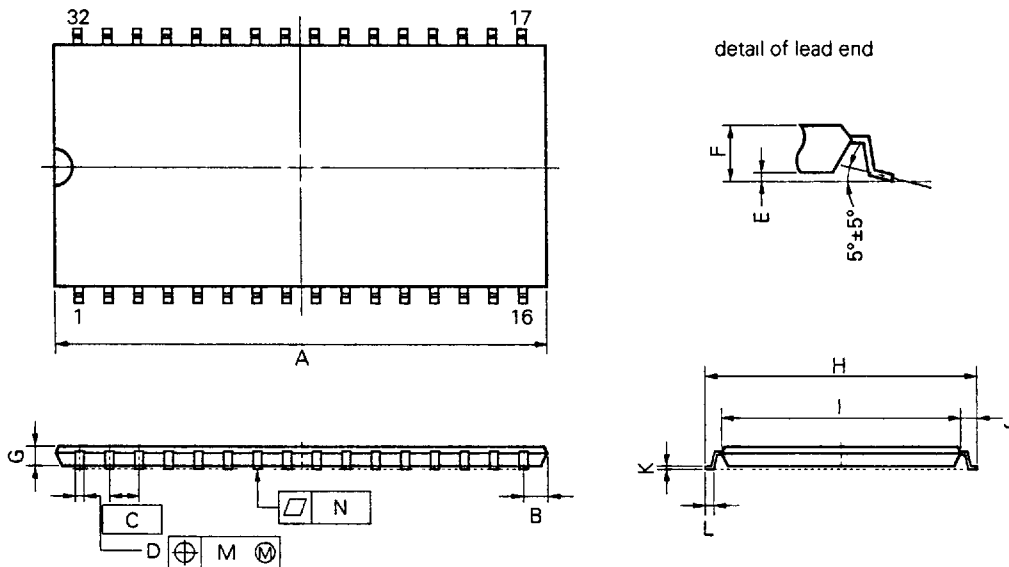

NOTE

Each lead centerline is located within 0.21 mm (0.009 inch) of its true position (T.P.) at maximum material condition.

S32G5-50-7JD1

ITEM	MILLIMETERS	INCHES
A	21.17 MAX.	0.834 MAX.
B	1.06 MAX.	0.042 MAX.
C	1.27 (T.P.)	0.050 (T.P.)
D	0.40±0.10	0.016 ^{+0.004} _{-0.005}
E	0.05±0.05	0.002±0.002
F	1.1 MAX.	0.044 MAX.
G	0.97	0.038
H	11.76±0.2	0.463±0.008
I	10.16±0.1	0.400±0.004
J	0.8±0.2	0.031 ^{+0.009} _{-0.008}
K	0.125 ^{+0.10} _{-0.05}	0.005 ^{+0.004} _{-0.002}
L	0.5±0.15	0.020 ^{+0.006} _{-0.007}
M	0.21	0.009
N	0.10	0.004

32 PIN PLASTIC TSOP (400mil)
Reverse bent

NEC Cord:S32G5-50-7KD1

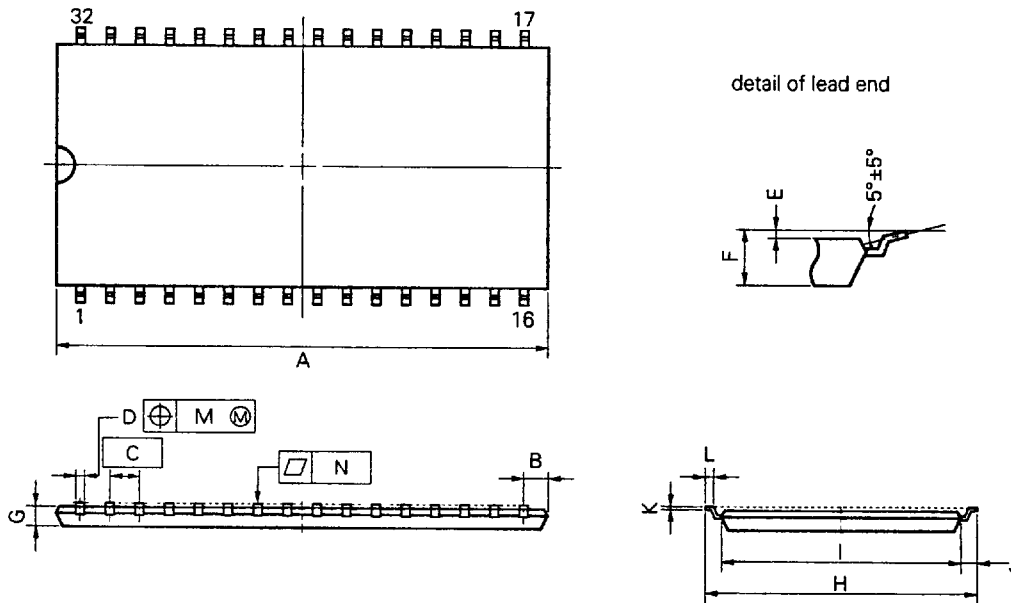

NOTE

Each lead centerline is located within 0.21 mm (0.009 inch) of its true position (T.P.) at maximum material condition.

S32G5-50-7KD1

ITEM	MILLIMETERS	INCHES
A	21.17 MAX.	0.834 MAX.
B	1.06 MAX.	0.042 MAX.
C	1.27 (T.P.)	0.050 (T.P.)
D	0.40±0.10	0.016 ^{+0.004} _{-0.005}
E	0.05±0.05	0.002±0.002
F	1.1 MAX.	0.044 MAX.
G	0.97	0.038
H	11.76±0.2	0.463±0.008
I	10.16±0.1	0.400±0.004
J	0.8±0.2	0.031 ^{+0.009} _{-0.008}
K	0.125 ^{+0.10} _{-0.05}	0.005 ^{+0.004} _{-0.002}
L	0.5±0.15	0.020 ^{+0.006} _{-0.007}
M	0.21	0.009
N	0.10	0.004

50 PIN PLASTIC TSOP (400mil)
44 Leads

NEC Cord:S50G5-80-7JF

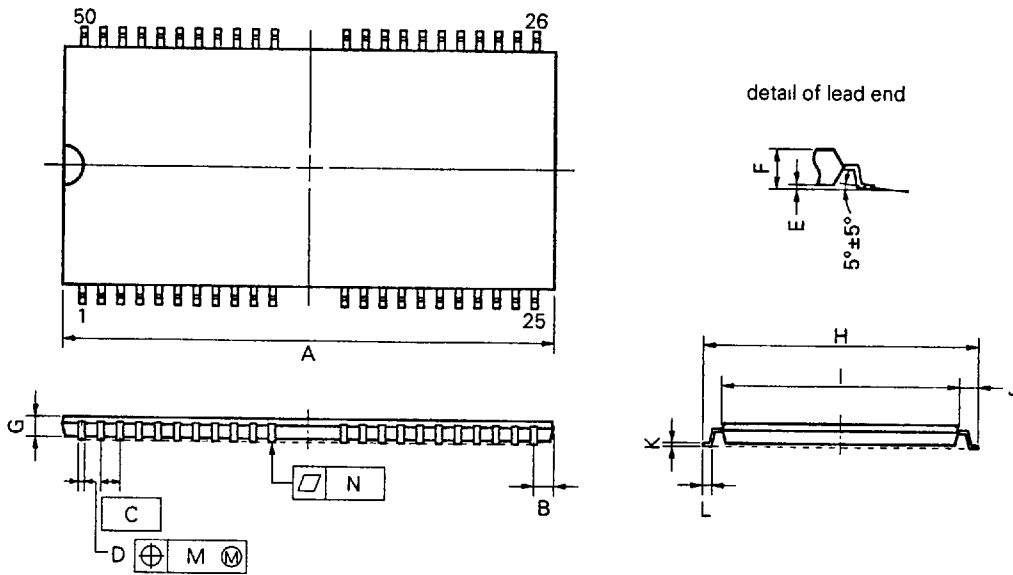

NOTE

Each lead centerline is located within 0.13 mm (0.005 inch) of its true position (T.P.) at maximum material condition.

S50G5-80-7JF

ITEM	MILLIMETERS	INCHES
A	21.45 MAX.	0.845 MAX.
B	1.13 MAX.	0.045 MAX.
C	0.8 (T.P.)	0.031 (T.P.)
D	0.30±0.10	0.012 ^{+0.004} _{-0.005}
E	0.05±0.05	0.002±0.002
F	1.1 MAX.	0.044 MAX.
G	0.97	0.038
H	11.76±0.2	0.463±0.008
I	10.16±0.1	0.400±0.004
J	0.8±0.2	0.031 ^{+0.009} _{-0.008}
K	0.125 ^{+0.10} _{-0.05}	0.005 ^{+0.004} _{-0.002}
L	0.5±0.15	0.020 ^{+0.006} _{-0.007}
M	0.13	0.005
N	0.10	0.004

50 PIN PLASTIC TSOP (400mil)
44 Leads Reverse bent

NEC Cord:S50G5-80-7KF

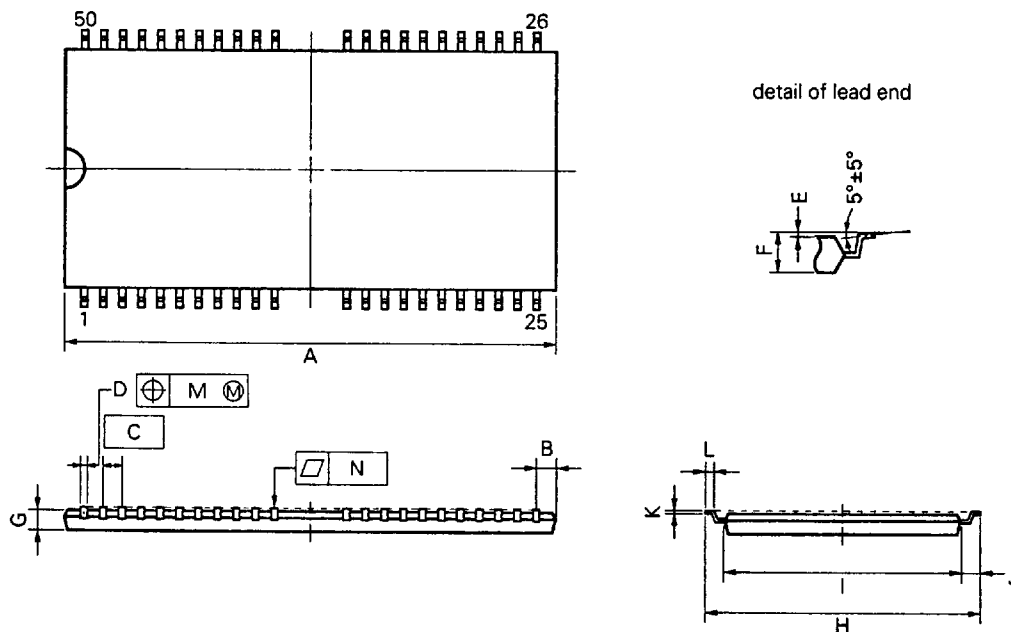

NOTE

Each lead centerline is located within 0.13 mm (0.005 inch) of its true position (T.P.) at maximum material condition.

S50G5-80-7KF

ITEM	MILLIMETERS	INCHES
A	21.45 MAX.	0.845 MAX.
B	1.13 MAX.	0.045 MAX.
C	0.8 (T.P.)	0.031 (T.P.)
D	0.30±0.10	0.012 ^{+0.004} / _{-0.005}
E	0.05±0.05	0.002±0.002
F	1.1 MAX.	0.044 MAX.
G	0.97	0.038
H	11.76±0.2	0.463±0.008
I	10.16±0.1	0.400±0.004
J	0.8±0.2	0.031 ^{+0.009} / _{-0.008}
K	0.125 ^{+0.10} / _{-0.05}	0.005 ^{+0.004} / _{-0.002}
L	0.5±0.15	0.020 ^{+0.006} / _{-0.007}
M	0.13	0.005
N	0.10	0.004

24 PIN PLASTIC ZIP (475mil)

NEC Cord:P24V-100-475A

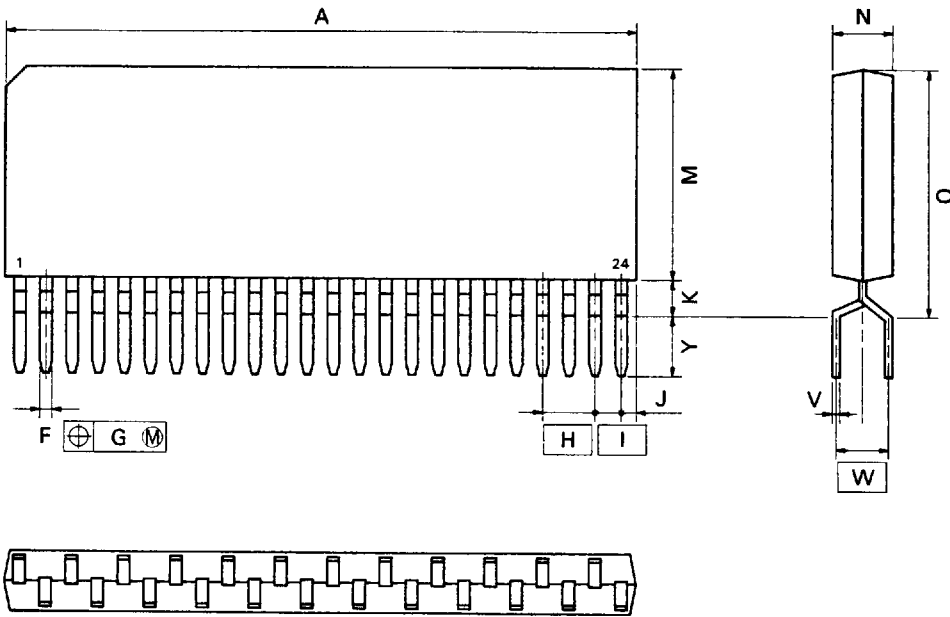

P24V-100-475A

NOTE

Each lead centerline is located within 0.25 mm (0.010 inch) of its true position (T.P.) at maximum material condition.

ITEM	MILLIMETERS	INCHES
A	31.75 MAX.	1.250 MAX.
F	0.50 ^{±0.1}	0.020 ^{-0.002}
G	φ0.25	φ0.010
H	2.54	0.100
I	1.27	0.050
J	1.27 MAX.	0.050 MAX.
K	1.0 MIN.	0.039 MIN.
M	10.8 MAX.	0.426 MAX.
N	2.8 ^{±0.2}	0.110 ^{-0.002}
Q	12.07 MAX.	0.476 MAX.
V	0.25 ^{+0.10}	0.010 ^{-0.004}
W	2.54	0.100
Y	3.3 ^{±0.5}	0.130 ^{±0.02}

28 PIN PLASTIC ZIP (475mil)

NEC Cord:P28VF-100-475A

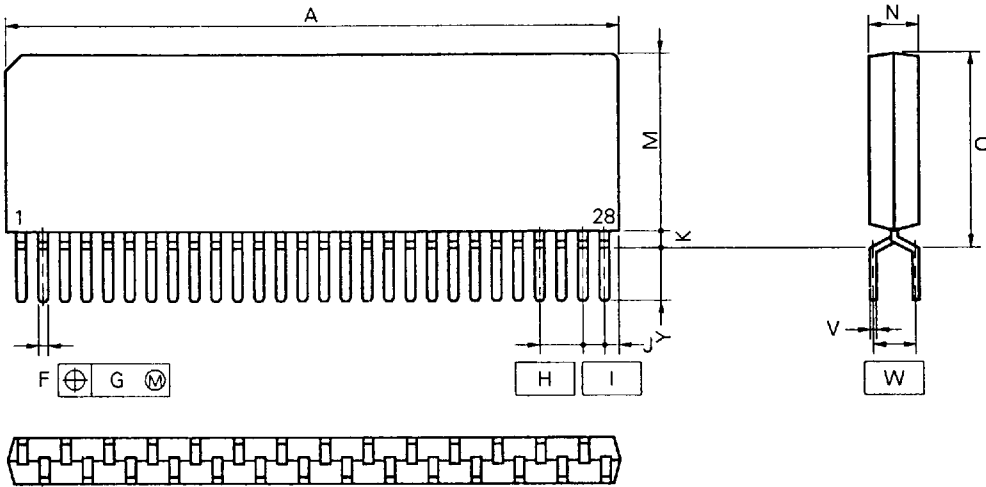

NOTE

Each lead centerline is located within 0.25 mm (0.010 inch) of its true position (T.P.) at maximum material condition.

P28VF-100-475A

ITEM	MILLIMETERS	INCHES
A	36.83 MAX.	1.450 MAX.
F	0.5 ± 0.10	0.020 ^{+0.004} _{-0.005}
G	0.25	0.010
H	2.54 (T.P.)	0.100 (T.P.)
I	1.27 (T.P.)	0.050 (T.P.)
J	1.27 MAX.	0.050 MAX.
K	0.9 MIN.	0.035 MIN.
M	10.8 MAX.	0.426 MAX.
N	2.8 ± 0.2	0.110 ^{+0.009} _{-0.008}
Q	12.07 MAX.	0.475 MAX.
V	0.25 ^{+0.10} _{-0.05}	0.010 ^{+0.004} _{-0.003}
W	2.54 (T.P.)	0.100 (T.P.)
Y	3.25 ± 0.2	0.128 ± 0.008

32 PIN PLASTIC ZIP (475mil)

NEC Cord:P32VF-100-475A

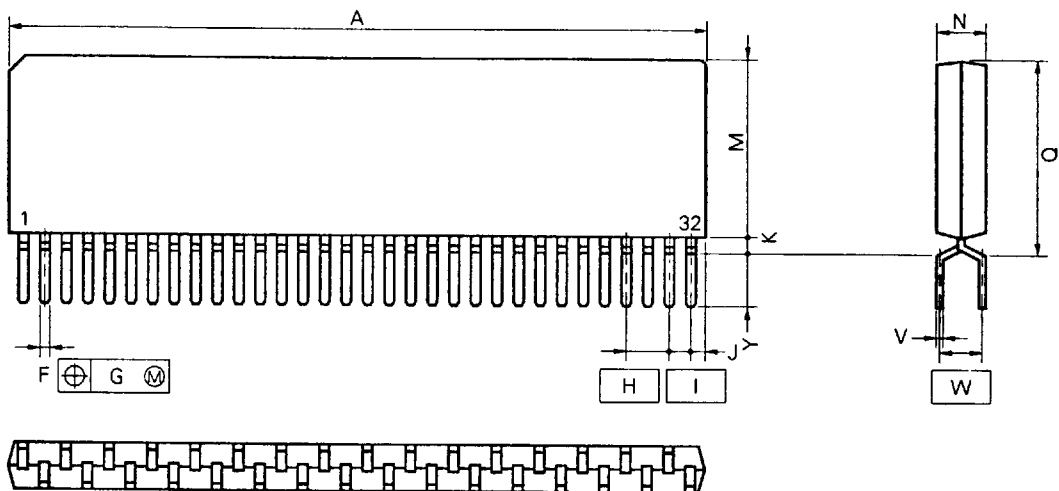

P32VF-100-475A

NOTE

Each lead centerline is located within 0.25 mm (0.010 inch) of its true position (T.P.) at maximum material condition.

ITEM	MILLIMETERS	INCHES
A	41.91 MAX.	1.650 MAX
F	0.5±0.10	0.020 ^{+0.004} _{-0.005}
G	0.25	0.010
H	2.54 (T.P.)	0.100 (T.P.)
I	1.27 (T.P.)	0.050 (T.P.)
J	1.27 MAX.	0.050 MAX.
K	0.9 MIN.	0.035 MIN.
M	10.8 MAX.	0.426 MAX.
N	2.8±0.2	0.110 ^{+0.009} _{-0.008}
Q	12.07 MAX.	0.475 MAX.
V	0.25 ^{+0.10} _{-0.05}	0.010 ^{+0.004} _{-0.003}
W	2.54 (T.P.)	0.100 (T.P.)
Y	3.25±0.2	0.128±0.008