

T-11-15

# IN5333-IN5388 SERIES

**High Power Zener Diode**  
**Voltage Range 3V3 to 200 Volts**  
**5.0 Watt Steady State**

## FEATURES

- High power regulator diode
- High surge capabilities
- 100% Tested
- -65°C to +200°C

## MECHANICAL DATA

- Case: Moulded thermosetting plastic
- Finish: All external surfaces are corrosion resistant. Leads are readily solderable.
- Polarity: Cathode indicated by colour band.
- Mounting Position: Any
- Weight: 0.7 grams

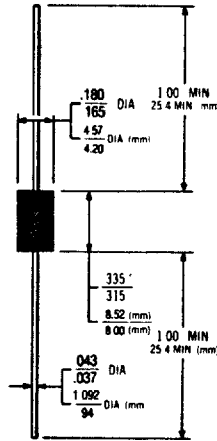

**POWER DERATING CURVE**

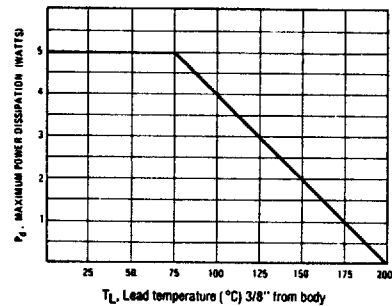

**TYPICAL ZENER IMPEDANCE VS. ZENER CURRENT FOR TYPES SHOWN**

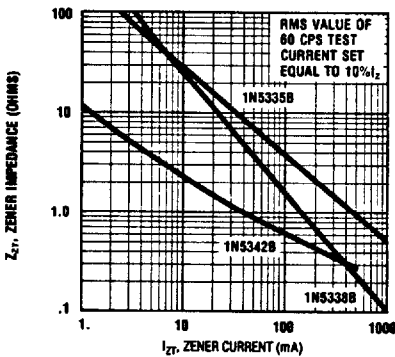

**TYPICAL ZENER IMPEDANCE VS. ZENER CURRENT FOR TYPES SHOWN**

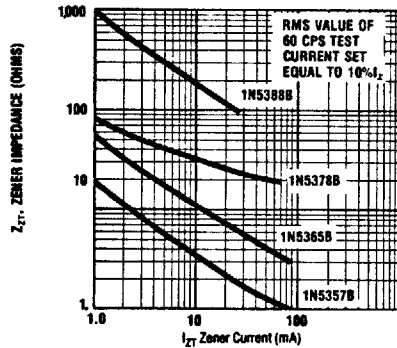

**TYPICAL CAPACITANCE vs REVERSE VOLTAGE FOR 5 WATT ZENERS**

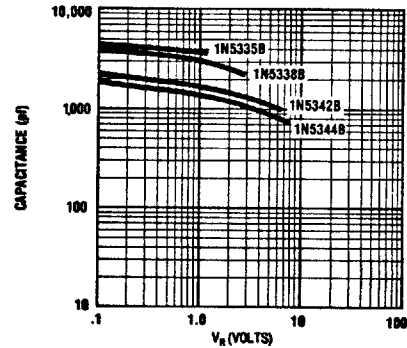

- NOTE 1** Devices listed have a  $\pm 5\%$  voltage tolerance on nominal  $V_Z$ . The suffix "A" denotes a  $\pm 10\%$  tolerance and NO SUFFIX denotes a  $\pm 20\%$  tolerance.
- NOTE 2** Nominal Zener Voltage ( $V_Z$ ) is read with the device in standard test clips with 3/8 to 1/2 inch spacing between clip and case of the diode. Before reading the diode is allowed to stabilize for a period of  $40 \pm 10$  milliseconds at  $25^\circ\text{C}$  ( $+8, -2^\circ\text{C}$ ).
- NOTE 3** The Zener Impedance ( $Z_{ZT}$  or  $Z_{ZK}$ ) is derived from the 60Hz ac voltage, which results when an ac current having a rms value equal to 10% of the DC zener current ( $I_{ZT}$  or  $I_{ZK}$ ) is superimposed on  $I_{ZT}$  or  $I_{ZK}$  respectively. This specification applies only to  $\pm 10\%$  and  $\pm 5\%$  devices.
- NOTE 4** The Maximum Reverse (leakage) Current is specified for devices with  $\pm 20\%$  and  $\pm 10\%$  voltage tolerances on nominal  $V_Z$  in one column and the reverse current for  $\pm 5\%$  tolerance devices in another column.
- NOTE 5** The Maximum Zener Current ( $I_{ZM}$ ) shown is for  $\pm 5\%$  tolerance devices.  $I_{ZM}$  for  $\pm 10\%$  and  $\pm 20\%$  devices can be calculated using the formula:

$$I_{ZM} = \frac{P}{V_{ZM}}$$

- where " $V_{ZM}$ " is  $V_Z$  at the high end of the voltage tolerance specified and "P" is the rated power of the device.
- NOTE 6** The Surge Current ( $I_S$ ) is specified as the maximum peak of a nonrecurrent sine wave of 8.3 milliseconds duration.
- NOTE 7** Voltage Regulation ( $\Delta V_Z$ ) is the difference between the voltage measured at 10% and 50% of  $I_{ZM}$ . This specification applies only to  $\pm 10\%$  and  $\pm 5\%$  devices.

**TYPICAL CAPACITANCE vs REVERSE VOLTAGE FOR 5 WATT ZENERS**

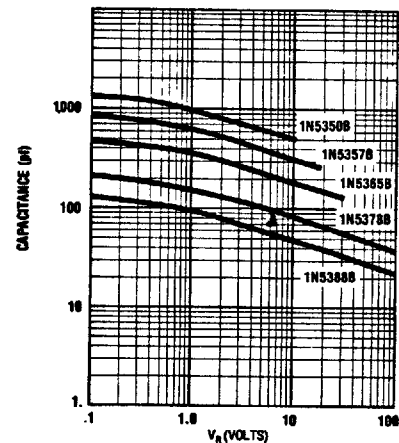



## Electrical Characteristics @ 25°C

Type Number	Regulator Voltage (V <sub>Z</sub> )	Test Current (I <sub>Z</sub> )	Maximum Dynamic Impedance (Z <sub>Z</sub> ) (A&B Suffix)	Maximum Reverse Current (I <sub>R</sub> )	I <sub>R</sub> Test Voltage (V <sub>R</sub> ) (Non-suffix & A Suffix)	I <sub>R</sub> Test Voltage (V <sub>R</sub> ) (B Suffix)	Maximum Regulator Current (I <sub>ZM</sub> ) (B Suffix)	Maximum Dynamic Knee Impedance Z <sub>ZK</sub> at 1.0 mA (A&B Suffix)	Maximum Surge Current (I <sub>S</sub> )	Maximum Voltage Regulation (ΔV <sub>2</sub> ) (A&B Suffix)
	V	mA dc	Ohms	μA	V	V	mA	Ohms	Amps	Volts
1N5333B	3.3	380	3.0	300	1.0	1.0	1440	400	20	0.85
1N5334B	3.6	350	2.5	150	1.0	1.0	1320	500	18.7	0.80
1N5335B	3.9	320	2.0	50	1.0	1.0	1220	500	17.6	0.54
1N5336B	4.3	290	2.0	10	1.0	1.0	1100	500	16.4	0.49
1N5337B	4.7	260	2.0	5.0	1.0	1.0	1010	450	15.3	0.44
1N5338B	5.1	240	1.5	1.0	1.0	1.0	930	400	14.4	0.39
1N5339B	5.6	220	1.0	1.0	2.0	2.0	865	400	13.4	0.25
1N5340B	6.0	200	1.0	1.0	3.0	3.0	790	300	12.7	0.19
1N5341B	6.2	200	1.0	1.0	3.0	3.0	765	200	12.4	0.10
1N5342B	6.8	175	1.0	1.0	4.9	5.2	700	200	11.5	0.15
1N5343B	7.5	175	1.5	10	5.4	5.7	630	200	10.7	0.15
1N5344B	8.2	150	1.5	10	5.9	6.2	580	200	10	0.20
1N5345B	8.7	150	2.0	10	6.25	6.6	545	200	9.5	0.20
1N5346B	9.1	150	2.0	7.5	6.6	6.9	520	150	9.2	0.22
1N5347B	10	125	2.0	5.0	7.2	7.6	475	125	8.6	0.22
1N5348B	11	125	2.5	5.0	8.0	8.4	430	125	8.0	0.25
1N5349B	12	100	2.5	2.0	8.6	9.1	395	125	7.5	0.25
1N5350B	13	100	2.5	1.0	9.4	9.9	365	100	7.0	0.25
1N5351B	14	100	2.5	1.0	10.1	10.6	340	75	6.7	0.25
1N5352B	15	75	2.5	1.0	10.8	11.5	315	75	6.3	0.25
1N5353B	16	75	2.5	1.0	11.5	12.2	295	75	6.0	0.30
1N5354B	17	70	2.5	0.5	12.2	12.9	280	75	5.8	0.35
1N5355B	18	65	2.5	0.5	13	13.7	264	75	5.5	0.40
1N5356B	19	65	3.0	0.5	13.7	14.4	250	75	5.3	0.40
1N5357B	20	65	3.0	0.5	14.4	15.2	237	75	5.1	0.40
1N5358B	22	50	3.5	0.5	15.8	16.7	216	75	4.7	0.45
1N5359B	24	50	3.5	0.5	17.3	18.2	198	100	4.4	0.55
1N5360B	25	50	4.0	0.5	18	19	190	110	4.3	0.55
1N5361B	27	50	5.0	0.5	19.4	20.6	176	120	4.1	0.60
1N5362B	28	50	6.0	0.5	20.1	21.2	170	130	3.9	0.60
1N5363B	30	40	8.0	0.5	21.6	22.8	158	140	3.7	0.60
1N5364B	33	40	10	0.5	23.8	25.1	144	150	3.5	0.60
1N5365B	36	30	11	0.5	25.9	27.4	132	160	3.3	0.65
1N5366B	39	30	14	0.5	28.1	29.7	122	170	3.1	0.65
1N5367B	43	30	20	0.5	31	32.7	110	190	2.8	0.70
1N5368B	47	25	25	0.5	33.8	35.8	100	210	2.7	0.80
1N5369B	51	25	27	0.5	36.7	38.8	93	230	2.5	0.90
1N5370B	56	20	35	0.5	40.3	42.6	86	280	2.3	1.00
1N5371B	60	20	40	0.5	43	45.5	79	350	2.2	1.20
1N5372B	62	20	42	0.5	44.6	47.1	76	400	2.1	1.35
1N5373B	68	20	44	0.5	49	51.7	70	500	2.0	1.50
1N5374B	75	20	45	0.5	54	56	63	620	1.9	1.60
1N5375B	82	15	65	0.5	59	62.2	58	720	1.8	1.80
1N5376B	87	15	75	0.5	63	66	54.5	760	1.7	2.00
1N5377B	91	15	75	0.5	65.5	69.2	52.5	760	1.6	2.20
1N5378B	100	12	90	0.5	72	76	47.5	800	1.5	2.30
1N5379B	110	12	125	0.5	79.2	83.6	43	1000	1.4	2.50
1N5380B	120	10	170	0.5	86.4	91.2	39.5	1150	1.3	2.50
1N5381B	130	10	190	0.5	93.6	98.8	36.6	1250	1.2	2.50
1N5382B	140	8.0	230	0.5	101	106	34	1500	1.2	2.50
1N5383B	150	8.0	330	0.5	108	114	31.6	1500	1.1	3.00
1N5384B	160	8.0	350	0.5	115	122	29.4	1650	1.1	3.00
1N5385B	170	8.0	380	0.5	122	129	28	1750	1.0	3.00
1N5386B	180	5.0	430	0.5	130	137	26.4	1750	1.0	4.00
1N5387B	190	5.0	450	0.5	137	144	25	1850	0.9	5.00
1N5388B	200	5.0	480	0.5	144	152	23.6	1850	0.9	5.00

V<sub>f</sub> = 1.2V @ I<sub>f</sub> = 1.0AZENERS, REFERENCE  
AND LIMITERS

# OUTLINE DRAWINGS

Unit = inch (mm)

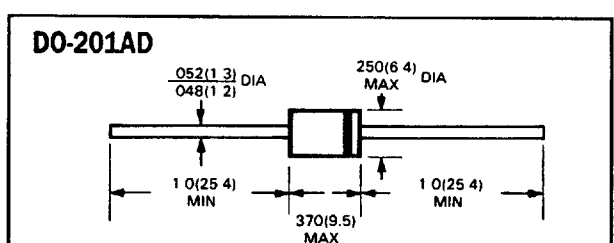
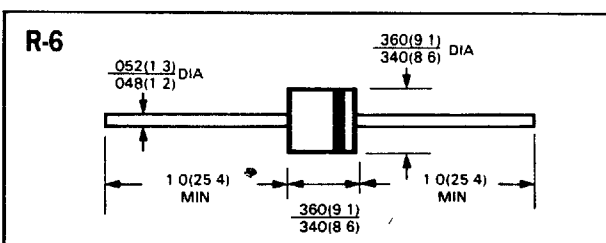
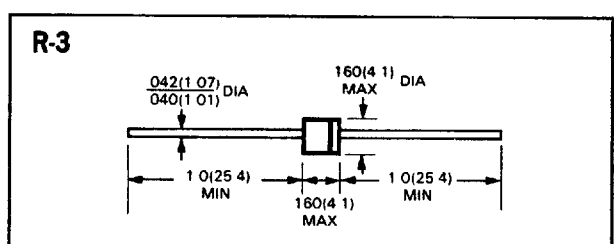
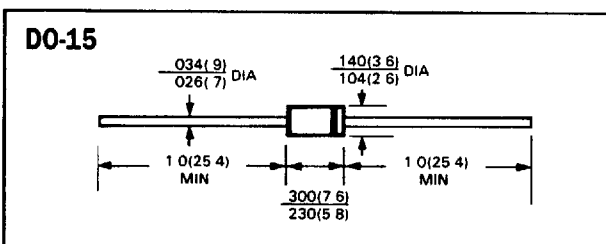
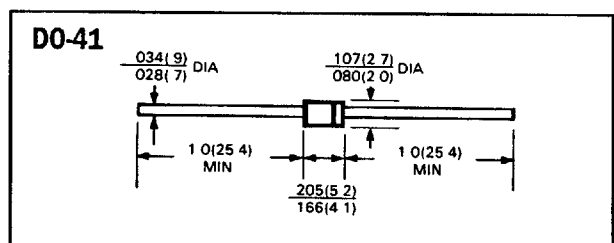
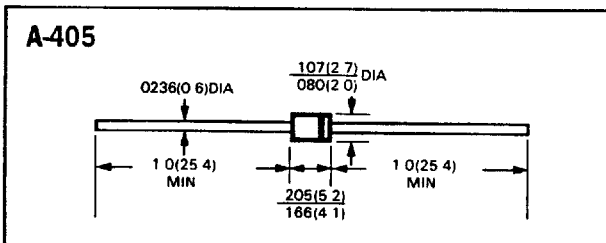
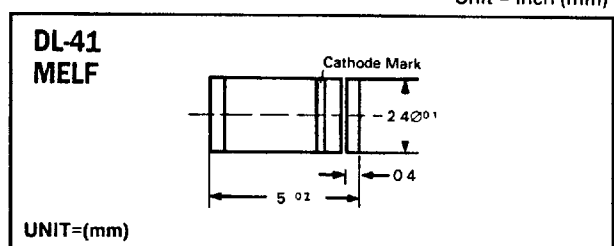
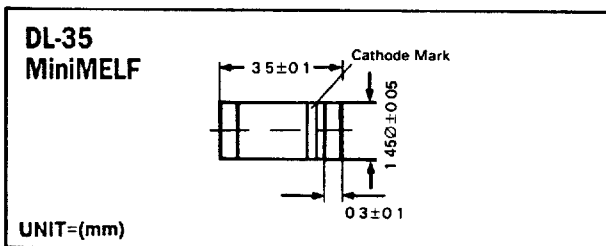



# OUTLINE DRAWINGS

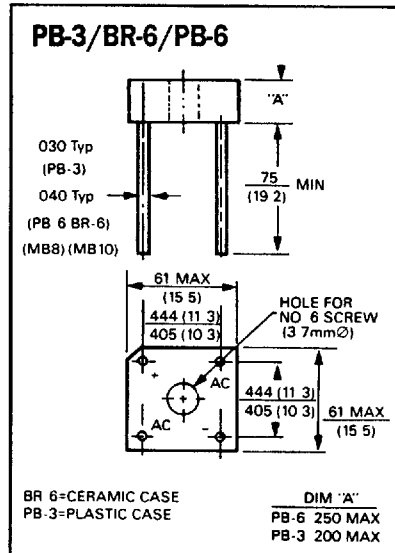
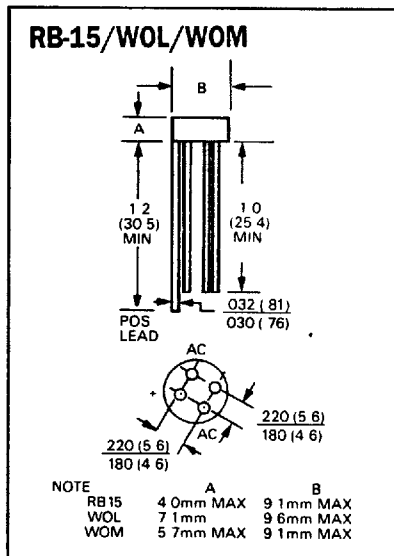
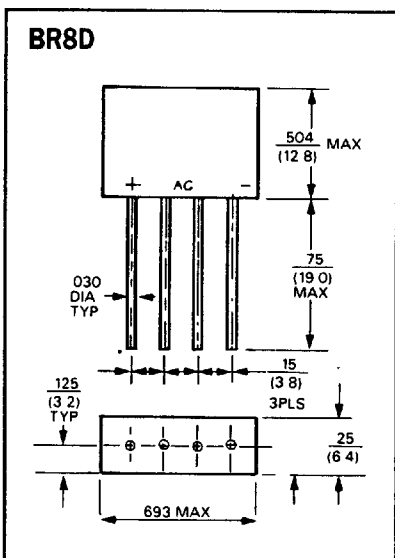
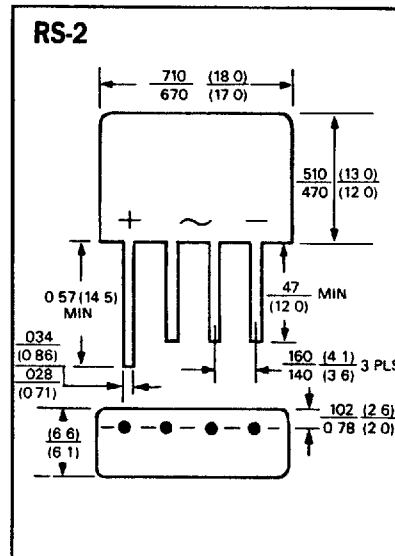
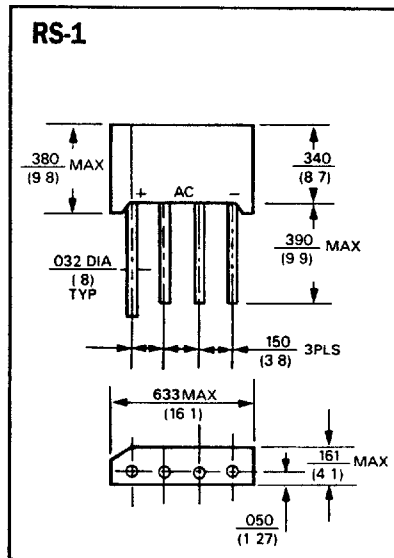
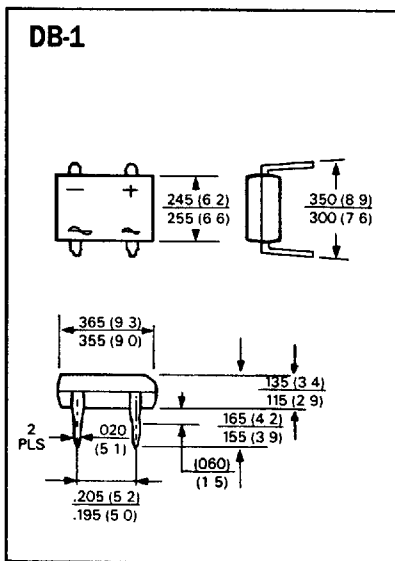

RECTIFIER DIODES AND BRIDGE RECTIFIERS

4

# OUTLINE DRAWINGS

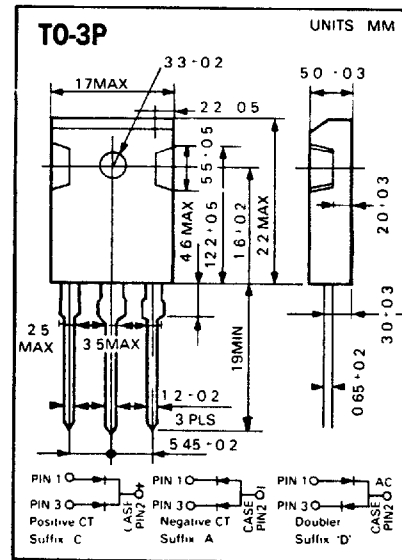
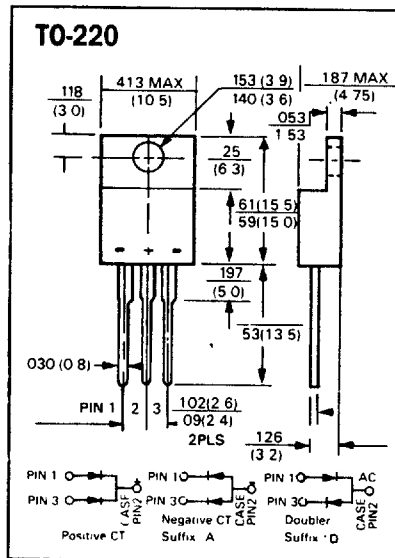
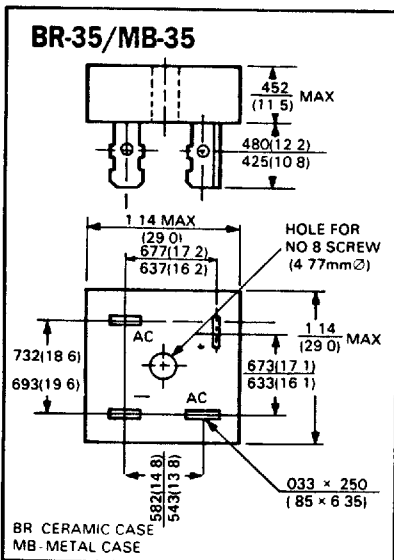
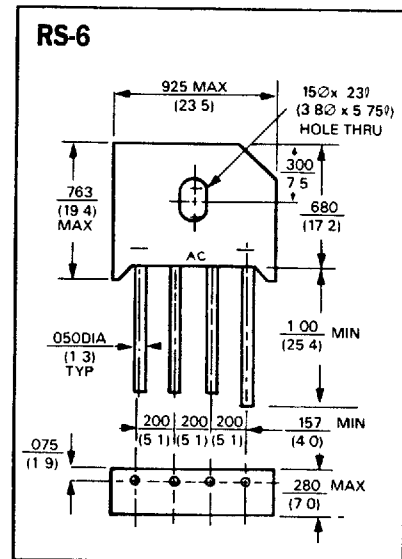
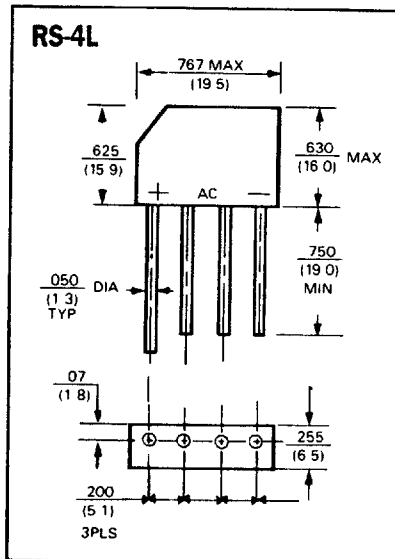
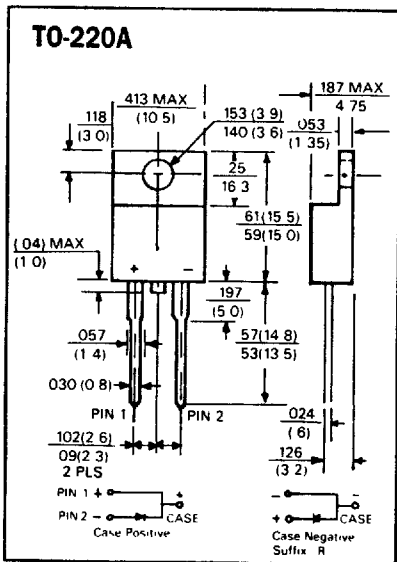

# RECTIFIERS

SEMITRON INDUSTRIES LTD

## Product Packaging Specifications

### PACKAGING OF AXIAL LEAD DIODES, MELF AND MINI-MELF SURFACE MOUNT DEVICES AND TRANSISTORS

#### REEL PACK

OUTLINE	COMPONENT SPACE (mm)	TAPE SPACE (mm)	REEL DIA. (m/m)	QTY./REEL (each)
DO-7	5.0	52.4	330	10,000
DO-35	5.0	53	355	10,000
DO-35 (ZENER)	[RADIAL TAPING SEE FIG. 1, 2 & 3]		355	5,000
DL-35 (MINI MELF)	See Pg. 37		250/330	5,000/10,000
DL-41 (MELF)	See Pg. 37		330	5,000
A-405	5.0	52.4	330	5,000
A-500	5.0	52.4	203/254/304	1,000/2,000/3,000
DO-41	5.0	52.4	330	5,000
DO-41 (ZENER)	5.0	53	355	5,000
DO-15	5.0	52.4	330	4,000
R-3	5.0	52.4	330	3,000
DO-201AD	10.0	52.4	330	1,200
R-6	10.0	52.4	330	500
TO-92	[RADIAL TAPING SEE FIG. 4, 5 & 6]		355	2,000
TO-236/SOT-23	[SEE SPECIFICATIONS ON PG.38]		178	3,000

### PACKAGING OF AXIAL LEAD DIODES AND LEADED TRANSISTORS

#### AMMO PACK

OUTLINE	COMPONENT SPACE (mm)	TAPE SPACE (mm)	BOX SIZE (m/m)	QTY./BOX (each)
DO-35 (SW. DIODES)	5.0	53	338/147/77	15,000
DO-35	5.0	53	255/95/85	6,000
DO-35	5.0	26	255/95/51	6,000
A-405	5.0	52.4	255/95/78	3,000
DO-41	5.0	52.4	255/95/78	3,000
DO-41	5.0	26	255/51/95	3,000
DO-41 (ZENER)	5.0	53	255/95/85	3,000
DO-41 (ZENER)	5.0	26	255/95/51	3,000
DO-15	5.0	52.4	255/95/78	2,200
R-3	5.0	52.4	255/95/78	2,000
DO-201AD	10.0	52.4	255/95/78	800
R-6	10.0	52.4	255/95/78	300
TO-92	[RADIAL TAPING, SEE FIG. 4]		340/340/45	4,000

RECTIFIER DIODES AND  
BRIDGE RECTIFIERS

4

