



TSH151

WIDE BANDWIDTH AND MOS INPUTS SINGLE OPERATIONAL AMPLIFIER

- LOW DISTORTION
- GAIN BANDWIDTH PRODUCT : 150MHz
- UNITY GAIN STABLE
- SLEW RATE : 200V/ μ s
- VERY FAST SETTTLING TIME : 70ns (0.1%)
- VERY HIGH INPUT IMPEDANCE

DESCRIPTION:

The TSH151 is a wideband monolithic operational amplifier, internally compensated for unity-gain stability.

The TSH151 features extremely high input impedance (typically greater than $10^{12}\Omega$) allowing direct interfacing with high impedance sources.

Low distortion, wide bandwidth and high linearity make this amplifier suitable for RF and video applications. Short circuit protection is provided by an internal current-limiting circuit.

The TSH151 has internal electrostatic discharge (ESD) protection circuits and fulfills MILSTD883C-Class2.

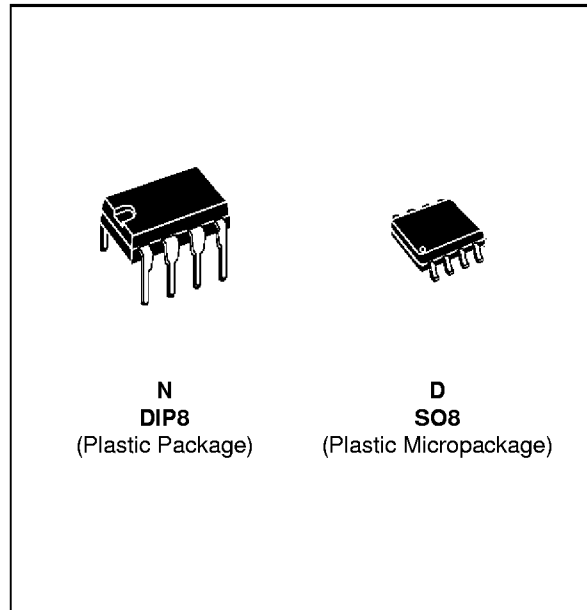

ORDER CODES

Part Number	Temperature Range	Package	
		N	D
TSH151C	0°C, 70°C	•	•
TSH151I	-40°C, 125°C	•	•

151-01.TBL

PIN CONNECTIONS (top view)

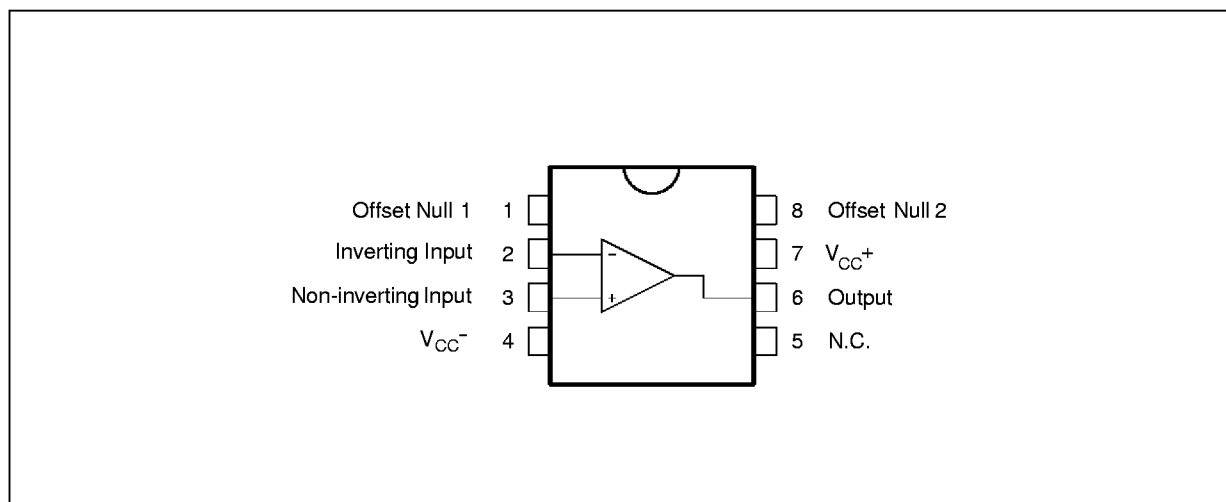

151-01.EPS

SCHEMATIC DIAGRAM

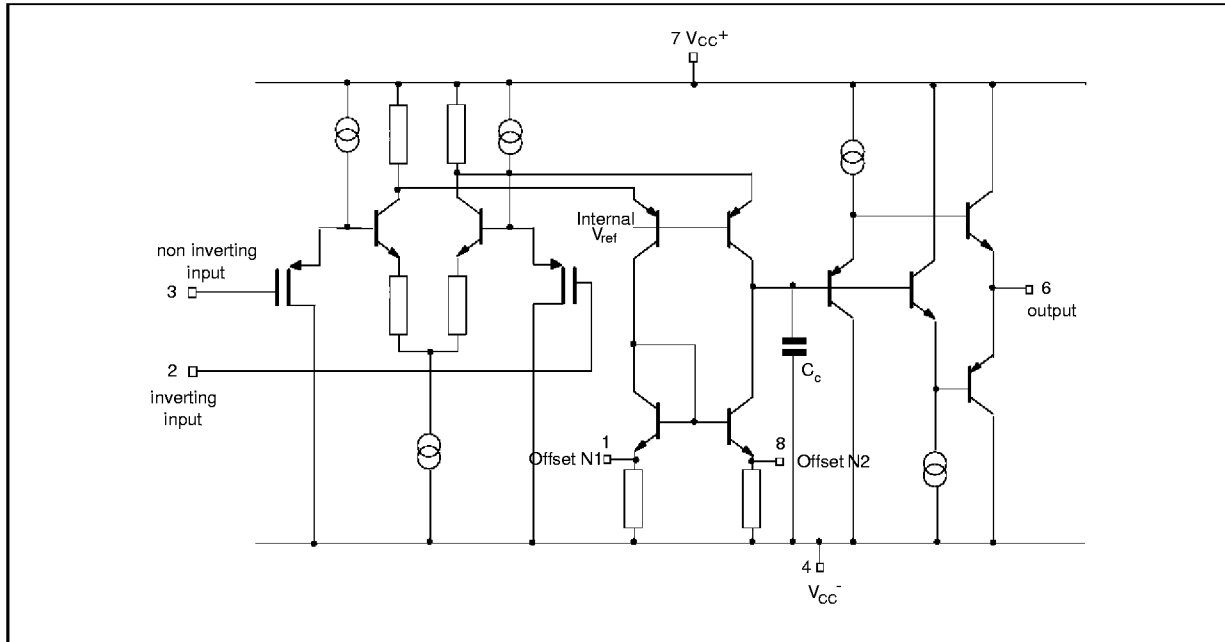

151-02.EPS

INPUT OFFSET VOLTAGE NULL CIRCUIT

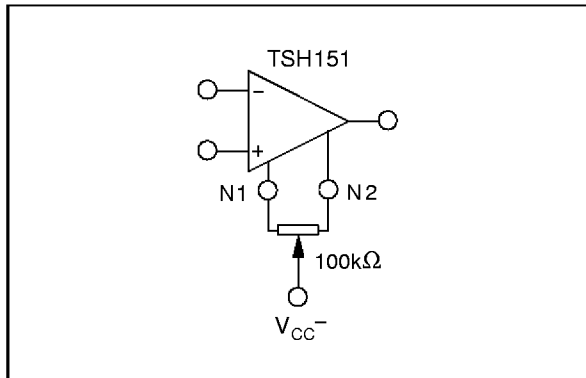

151-03.EPS

ABSOLUTE MAXIMUM RATINGS

Symbol	Parameter	Value	Unit
V_{CC}	Supply Voltage	± 7	V
V_{id}	Differential Input Voltage	± 5	V
V_i	Input Voltage Range	± 5	V
I_{in}	Current On Offset Null Pins	± 20	mA
T_{oper}	Operating Free-Air Temperature Range	TSH151C TSH151I	$0^{\circ}\text{C}, 70^{\circ}\text{C}$ $-40^{\circ}\text{C}, 15^{\circ}\text{C}$

151-02.TBL

OPERATING CONDITIONS

Symbol	Parameter	Value	Unit
V_{CC}	Supply Voltage	± 3 to ± 6	V
V_{ic}	Common Mode Input Voltage Range	V_{CC-} to $V_{CC+} - 3$	V

151-03.TBL

ELECTRICAL CHARACTERISTICS

 $V_{CC} = \pm 5V$, $T_{amb} = 25^{\circ}C$ (unless otherwise specified)

Symbol	Parameter	TSH151C, I			Unit
		Min.	Typ.	Max.	
V_{io}	Input Offset Voltage $T_{min} \leq T_{amb} \leq T_{max}$.		0.5	10 12	mV
DV_{io}	Input Offset Voltage Drift $T_{min} \leq T_{amb} \leq T_{max}$.		10		$\mu V/^{\circ}C$
I_{ib}	Input Bias Current		2	300	pA
I_{io}	Input Offset Current		2	200	pA
I_{CC}	Supply Current, no load $T_{min} \leq T_{amb} \leq T_{max}$.	$V_{CC} = \pm 5V$ $V_{CC} = \pm 3V$ $V_{CC} = \pm 6V$ $V_{CC} = \pm 5V$		23 21 25 30 28 40 32	mA
A_{vd}	Large Signal Voltage Gain $V_o = \pm 2.5V$	$R_L = \infty$ $R_L = 100\Omega$ $R_L = 50\Omega$	800 300 200	1300 850 650	V/V
V_{icm}	Input Common Mode Voltage Range		-5 to +2	-5.5 to +2.5	V
CMR	Common Mode Rejection Ratio $V_{ic} = V_{icm\ min}$.		60	100	dB
SVR	Supply Voltage Rejection Ratio $V_{CC} = \pm 5V$ to $\pm 3V$		50	70	dB
V_o	Output Voltage $T_{min} \leq T_{amb} \leq T_{max}$.	$R_L = 100\Omega$ $R_L = 50\Omega$ $R_L = 100\Omega$ $R_L = 50\Omega$	± 3 ± 2.8 ± 2.9 ± 2.7	+3.5 -3.7 +3.3 -3.5	V
I_o	Output Short Circuit Current $V_{id} = \pm 1V$, $V_o = 0V$		± 50	± 100	mA
GBP	Gain Bandwidth Product $A_{VCL} = 100$, $R_L = 100\Omega$, $C_L = 15pF$, $f = 7.5MHz$			150	MHz
SR	Slew Rate $V_{in} = \pm 2V$, $A_{VCL} = 1$, $R_L = 100\Omega$, $C_L = 15pF$		100	200	V/ μs
e_n	Equivalent Input Voltage Noise $R_S = 50\Omega$	$f_o = 1kHz$ $f_o = 10kHz$ $f_o = 100kHz$ $f_o = 1MHz$		20 18.2 18.1 18.2	$\frac{nV}{\sqrt{Hz}}$
K_{ov}	Overshoot $V_{in} = \pm 2V$, $A_{VCL} = 1$, $R_L = 100\Omega$, $C_L = 15pF$			10	%
t_s	Settling Time 0.1% - (note 1) $V_{in} = \pm 1V$, $A_{VCL} = -1$			70	ns
t_r , t_f	Rise and Fall Time - (note 1) $V_{in} = \pm 100mV$, $A_{VCL} = 2$			5	ns
t_d	Delay Time - (note 1) $V_{in} = \pm 100mV$, $A_{VCL} = 2$			4	ns
ϕ_m	Phase Margin $A_{VM} = 1$, $R_L = 100\Omega$, $C_L = 15pF$			45	Degrees
THD	Total Harmonic Distortion $A_{VCL} = 10$, $f = 1KHz$, $V_o = \pm 2.5V$, no load			0.02	%
FPB	Full Power Bandwidth - (note 2) $V_o = 5V_{pp}$, $R_L = 100\Omega$ $V_o = 2V_{pp}$, $R_L = 100\Omega$			13 32	MHz

Note 1 : See test waveform figure

Note 2 : Full power bandwidth = $\frac{SR}{\pi V_{opp}}$

TEST WAVEFORM

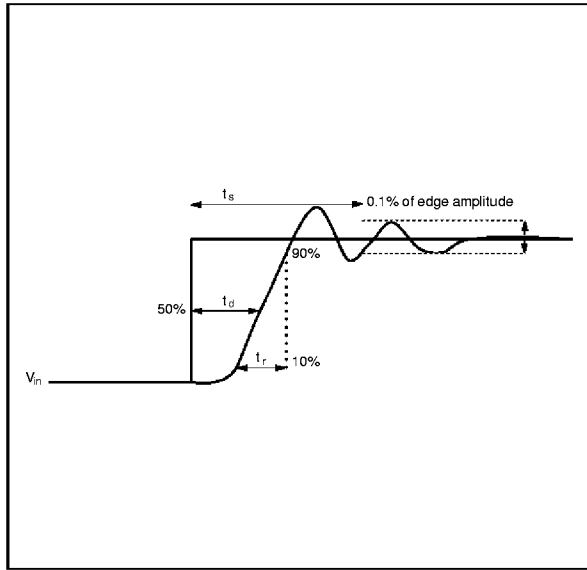

151-04.EPS

EVALUATION CIRCUIT

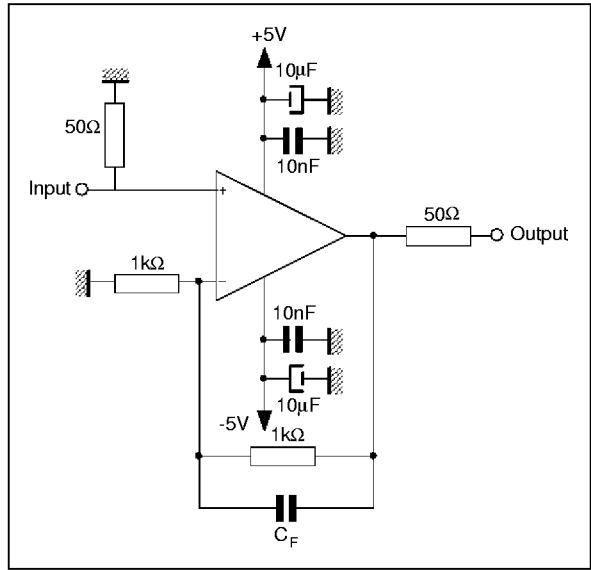

151-05.EPS

PRINTED CIRCUIT LAYOUT

As for any high frequency device, a few rules must be observed when designing the PCB to get the best performances from your this speed op amp.

From the most to the least important points :

- Each power supply lead has to be bypassed to ground with a 10nF ceramic capacitor very close to the device and a 10μF tantalum capacitor.
- To provide low inductance and low resistance common return, use a ground plane or common point return for power and signal.
- All leads must be wide and as short as possible especially for op amp inputs. This is in order to decrease parasitic capacitance and

inductance.

- Use small resistor values to decrease time constant with parasitic capacitance.
- Choose component sizes as small as possible (SMD).
- On output, decrease capacitor load so as to avoid circuit stability being degraded which may cause oscillation. One can also add a serial resistor in order to minimise its influence.
- One can add in parallel with feedback resistor a few pF ceramic capacitor C_F adjusted to optimize the settling time.

MACROMODEL

- LOW DISTORTION
- GAIN BANDWIDTH PRODUCT : 150MHz
- UNITY GAIN STABLE
- SLEW RATE : 200V/μs
- VERY FAST SETTTLING TIME : 70ns (0.1%)
- VERY HIGH INPUT IMPEDANCE

Applies to : TSH151C,I

** Standard Linear lcs Macromodels, 1993.

** CONNECTIONS :

* 1 INVERTING INPUT

* 2 NON-INVERTING INPUT

* 3 OUTPUT

* 4 POSITIVE POWER SUPPLY

* 5 NEGATIVE POWER SUPPLY

.SUBCKT TSH151 1 3 2 4 5 (analog)

.MODEL MDTH D IS=1E-8 KF=3.322525E-14 CJO=10F

* INPUT STAGE

RESD1 2 202 150

RESD2 1 201 150

CIP 202 5 10.000000E-12

CIN 201 5 10.000000E-12

EIP 10 5 202 5 1

EIN 16 5 201 5 1

RIP 10 11 2.600000E-01

RIN 15 16 2.600000E-01

RIS 11 15 1.683423E-01

DIP 11 12 MDTH 400E-12

DIN 15 14 MDTH 400E-12

VOFP 12 13 DC 0.000000E+00

VOFN 13 14 DC 0

IPOL 13 5 1.000000E-03

CPS 11 15 8E-09

DINN 17 13 MDTH 400E-12

VIN 17 5 1.500000E+00

DINR 15 18 MDTH 400E-12

VIP 4 18 5.000000E-01

FCP 4 5 VOFP 2.200000E+01

FCN 5 4 VOFN 2.200000E+01

* AMPLIFYING STAGE

FIP 5 19 VOFP 3.800000E+02

FIN 5 19 VOFN 3.800000E+02

RG1 19 5 1.455096E+03

RG2 19 4 1.455096E+03

CC 19 29 2.000000E-09

HZTP 29 30 VOFP 100

HZTN 30 5 VOFN 100

DOPM 19 22 MDTH 400E-12

DONM 21 19 MDTH 400E-12

HOPM 22 28 VOUT 5.000000E+02

VIPM 28 4 5.000000E+01

HONM 21 27 VOUT 5.000000E+02

VINM 5 27 5.000000E+01

EOUT 26 23 19 5 1

VOUT 23 5 0

ROUT 26 3 9.978126E+00

COUT 3 5 1.000000E-13

DOP 19 25 MDTH 400E-12

VOP 4 25 1.946965E+00

DON 24 19 MDTH 400E-12

VON 24 5 1.946965E+00

.ENDS

ELECTRICAL CHARACTERISTICS

$V_{CC} = \pm 5V$, $T_{amb} = 25^{\circ}C$ (unless otherwise specified)

Symbol	Conditions	Value	Unit
V_{io}		0	mV
A_{vd}	$R_L = 100\Omega$	1.18	V/mV
I_{CC}	No load, per operator	23	mA
V_{icm}		-5 to 2.5	V
V_{OH}	$R_L = 100\Omega$	+3.6	V
V_{OL}	$R_L = 100\Omega$	-3.6	V
I_{sink}	$V_O = 0V$	108	mA
I_{source}	$V_O = 0V$	108	mA
GBP	$R_L = 100\Omega$, $C_L = 15pF$	130	MHz
SR	$R_L = 100\Omega$, $C_L = 15pF$	172	V/μs
\varnothing_m	$R_L = 100\Omega$, $C_L = 15pF$	25	Degrees
t_s	$A_v = -1$ at 0.1%	40	ns

PACKAGE MECHANICAL DATA
8 PINS - PLASTIC DIP

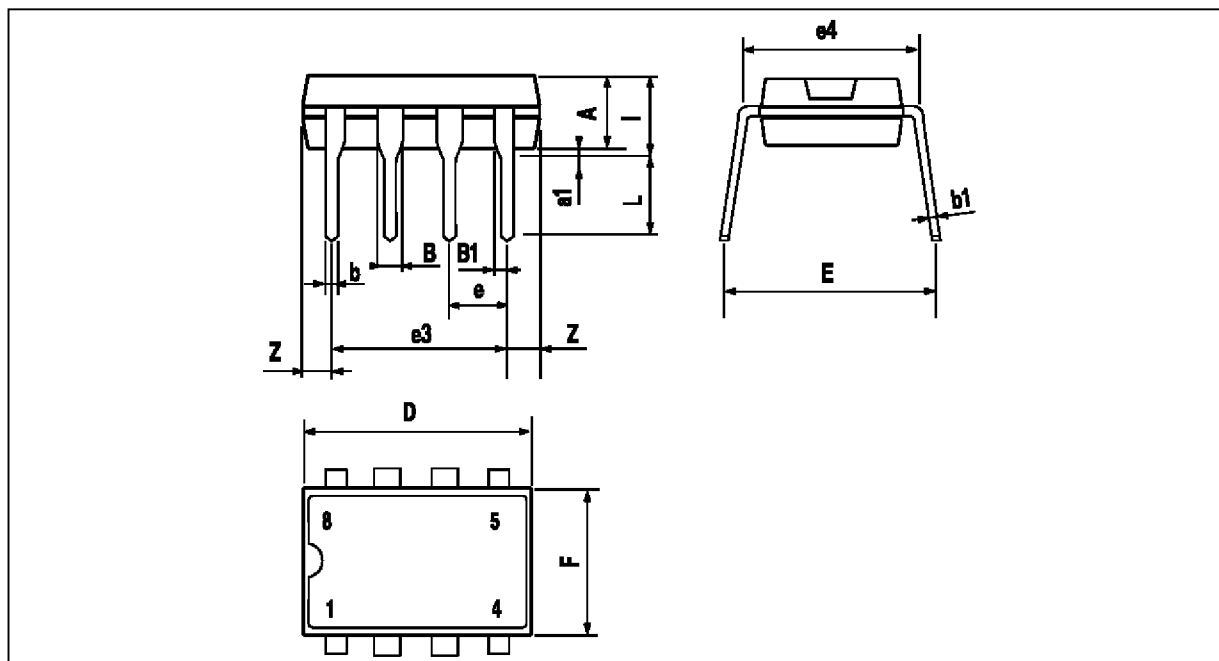

PM-DIP8.EPS

Dimensions	Millimeters			Inches		
	Min.	Typ.	Max.	Min.	Typ.	Max.
A		3.32			0.131	
a1	0.51			0.020		
B	1.15		1.65	0.045		0.065
b	0.356		0.55	0.014		0.022
b1	0.204		0.304	0.008		0.012
D			10.92			0.430
E	7.95		9.75	0.313		0.384
e		2.54			0.100	
e3		7.62			0.300	
e4		7.62			0.300	
F			6.6			0.260
i			5.08			0.200
L	3.18		3.81	0.125		0.150
Z			1.52			0.060

DIP8.TBL

PACKAGE MECHANICAL DATA
8 PINS - PLASTIC MICROPACKAGE (SO)

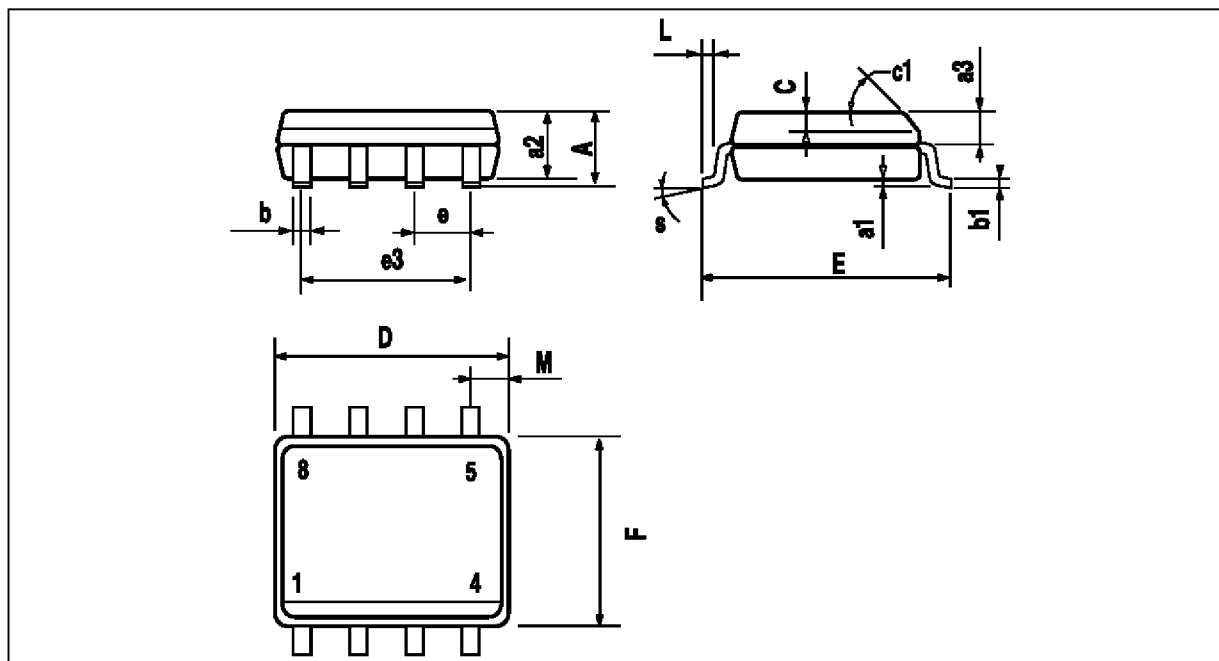

PM-SO8.EPS

Dimensions	Millimeters			Inches		
	Min.	Typ.	Max.	Min.	Typ.	Max.
A			1.75			0.069
a1	0.1		0.25	0.004		0.010
a2			1.65			0.065
a3	0.65		0.85	0.026		0.033
b	0.35		0.48	0.014		0.019
b1	0.19		0.25	0.007		0.010
C	0.25		0.5	0.010		0.020
c1	45° (typ.)					
D	4.8		5.0	0.189		0.197
E	5.8		6.2	0.228		0.244
e		1.27			0.050	
e3		3.81			0.150	
F	3.8		4.0	0.150		0.157
L	0.4		1.27	0.016		0.050
M			0.6			0.024
S	8° (max.)					

SO8.TBL

Information furnished is believed to be accurate and reliable. However, STMicroelectronics assumes no responsibility for the consequences of use of such information nor for any infringement of patents or other rights of third parties which may result from its use. No license is granted by implication or otherwise under any patent or patent rights of STMicroelectronics. Specifications mentioned in this publication are subject to change without notice. This publication supersedes and replaces all information previously supplied. STMicroelectronics products are not authorized for use as critical components in life support devices or systems without express written approval of STMicroelectronics.

© The ST logo is a trademark of STMicroelectronics

© 1998 STMicroelectronics – Printed in Italy – All Rights Reserved
STMicroelectronics GROUP OF COMPANIES

Australia - Brazil - Canada - China - France - Germany - Italy - Japan - Korea - Malaysia - Malta - Mexico - Morocco
The Netherlands - Singapore - Spain - Sweden - Switzerland - Taiwan - Thailand - United Kingdom - U.S.A.

ORDER CODE :