

# CGS74LCT2524

## 1 to 4 Minimum Skew (300 ps) 3V Clock Driver

### General Description

This minimum skew clock driver is a 3V option of the current CGS74CT2524 Minimum Skew Clock Driver and is designed for Clock Generation and Support (CGS) applications operating at low voltage, high frequencies. This device guarantees minimum output skew across the outputs of a given device.

Skew parameters are also provided as a means to measure duty cycle requirements as those found in high speed clocking systems. This minimum skew clock driver with one input driving four outputs, is specifically designed for signal generation and clock distribution applications.

### Features

- Ideal for low power/low noise high speed applications
- Guaranteed:
  - 300 ps pin-to-pin skew ( $t_{OSHL}$  and  $t_{OSLH}$ )
- Implemented on National's FACT™ family process
- 1 input to 4 outputs low skew clock distribution
- Symmetric output current drive: 12 mA  $I_{OH}/I_{OL}$
- Industrial temperature of  $-40^{\circ}\text{C}$  to  $+85^{\circ}\text{C}$
- 8-pin SOIC package
- Low dynamic power consumption above 20 MHz
- Guaranteed 2 kV ESD protection

### Logic Symbol

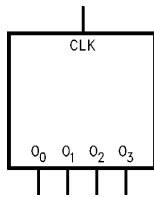

TL/F/11956-1

The output pins act as a single entity and will follow the state of the CLK when the clock distribution chip is selected.

### Connection Diagrams

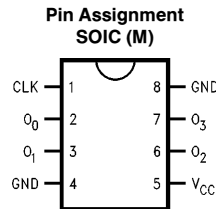

TL/F/11956-2

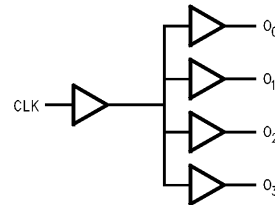

TL/F/11956-3

See NS Package Number M08A

### Pin Description

Pin Names	Description
CLK	Clock Input
$O_0-O_3$	Outputs

### Truth Table

Inputs CLK	Outputs $O_0-O_3$
L	L
H	H

L = Low Logic Level  
H = High Logic Level

FACT™ is a trademark of National Semiconductor Corporation.

**CGS74LCT2524 1 to 4 Minimum Skew (300 ps) 3V Clock Driver**

## Absolute Maximum Ratings (Note)

If Military/Aerospace specified devices are required, please contact the National Semiconductor Sales Office/Distributors for availability and specifications.

Supply Voltage ( $V_{CC}$ )	-0.5V to 7.0V
DC Input Voltage Diode Current ( $I_{IK}$ )	
$V = -0.5V$	-20 mA
$V = V_{CC} + 0.5V$	+20 mA
DC Input Voltage ( $V_I$ )	-0.5V to $V_{CC} + 0.5V$
DC Output Diode Current ( $I_O$ )	
$V = -0.5V$	-20 mA
$V = V_{CC} + 0.5V$	+20 mA
DC Output Voltage ( $V_O$ )	-0.5V to $V_{CC} + 0.5V$
DC Output Source or Sink Current ( $I_O$ )	±50 mA
DC $V_{CC}$ or Ground Current per Output Pin ( $I_{CC}$ or $I_{GND}$ )	±50 mA
Storage Temperature ( $T_{STG}$ )	-65°C to +150°C
Junction Temperature ( $\theta_{JA}$ )	

Airflow	0	225	500 LFM
M	167	132	117 °C/W

## Recommended Operating Conditions

Supply Voltage ( $V_{CC}$ )	3.0V to 3.6V
Input Voltage ( $V_{IN}$ )	0V to $V_{CC}$
Output Voltage ( $V_O$ )	0V to $V_{CC}$
Operating Temperature ( $T_A$ )	
Industrial	-40°C to +85°C
Commercial	0°C to +70°C
Input Rise and Fall Times (0.8V to 2.0V)	9.6 ns max

Note: The Absolute Maximum Ratings are those values beyond which the safety of the device cannot be guaranteed. The device should not be operated at these limits. The parametric values defined in the DC and AC Electrical Characteristics tables are not guaranteed at the absolute maximum ratings. The Recommended Operating Conditions will define the conditions for actual device operation.

## DC Electrical Characteristics Over recommended operating conditions unless specified otherwise.

Symbol	Parameter	Conditions	$V_{CC}$ (V)	CGS74LCT2524			Units
				$T_A = +25^\circ\text{C}$		$T_A = -40^\circ\text{C to } +85^\circ\text{C}$	
				Typ	Guaranteed Limits		
$V_{IH}$	Minimum High Level Input Voltage	$V_{OUT} = 0.1V$ or $V_{CC} = -0.1V$	3.3	1.5	2.0	2.0	V
$V_{IL}$	Maximum Low Level Input Voltage	$V_{OUT} = 0.1V$ or $V_{CC} = -0.1V$	3.3	1.5	0.8	0.8	V
$V_{OH}$	Minimum High Level Output Voltage	$V_{IN} = V_{IL}$ or $V_{IH}$ , $I_{OUT} = -50 \mu\text{A}$	3.3		2.9	2.9	V
		$V_{IN} = V_{IL}$ or $V_{IH}$ , $I_{OH} = -12 \text{ mA}$	3.3		2.5	2.4	V
$V_{OL}$	Minimum Low Level Output Voltage	$V_{IN} = V_{IL}$ or $V_{IH}$ , $I_{OUT} = 50 \mu\text{A}$	3.3		0.1	0.1	V
		$V_{IN} = V_{IL}$ or $V_{IH}$ , $I_{OL} = -12 \text{ mA}$	3.3		0.3	0.4	V
$I_{IN}$	Maximum Input Leakage Current	$V_{IN} = V_{CC}$ , GND	3.6		±0.1	±1.0	μA
$I_{CC_T}$	Maximum $I_{CC}$ /Input	$V_{IN} = 2.4V$	3.6			100	μA
$I_{OLD}$	Minimum Dynamic Output Current	$V_{OLD} = 0.8V$ (max)	3.6			36	mA
$I_{OHD}$		$V_{OHD} = 2.0V$ (min)	3.6			-25	mA
$I_{CC}$	Maximum Quiescent Supply Current	$V_{IN} = V_{CC}$ or GND	3.6		2.5	10	μA

## AC Electrical Characteristics

Over recommended operating conditions unless specified otherwise. All typical values are measured at  $V_{CC} = 3.3V$ ,  $T_A = 25^\circ C$

Symbol	Parameter	LCT2524			Units
		$V_{CC} = 3.0V \text{ to } 3.6V$ $T_A = -40^\circ C \text{ to } +85^\circ C$ $C_L = 50 \text{ pF}$ $R_L = 500\Omega$			
		Min	Typ	Max	
$t_{PLH}$	Low-to-High Propagation Delay CLK to $O_n$	6		15.0	ns
$t_{PHL}$	High-to-Low Propagation Delay CLK to $O_n$	6		15.0	ns

## Extended AC Electrical Characteristics

Over recommended operating conditions unless specified otherwise. All typical values are measured at  $V_{CC} = 3.3V$ ,  $T_A = 25^\circ C$

Symbol	Parameter	LCT2524			Units
		$V_{CC} = 3.0V \text{ to } 3.6V$ $T_A = -40^\circ C \text{ to } +85^\circ C$ $C_L = 50 \text{ pF}$ $R_L = 500\Omega$			
		Min	Typ	Max	
$f_{max}$	Maximum Operating Frequency		75		MHz
$t_{OSHL}$	Maximum Skew Common Edge Output-to-Output Variation (Note 1)			300	ps
$t_{OSLH}$	Maximum Skew Common Edge Output-to-Output Variation (Note 1)			300	ps
$t_{PS}$	Maximum Skew Pin (Signal) Transition Variation (Note 2)			2.5	ns
$t_{RISE}$ $t_{FALL}$	Rise Time/Fall Time (from 0.8V to 2.0V/2.0V to 0.8V)			1.75	ns
$T_{HIGH}$	Time High	4			ns
$T_{LOW}$	Time Low	4			ns

**Note 1:** Output-to-Output Skew is defined as the absolute value of the difference between the actual propagation delay for any outputs within the same packaged device. The specifications apply to any outputs switching in the same direction either HIGH-to-LOW ( $t_{OSHL}$ ) or LOW-to-HIGH ( $t_{OSLH}$ ) or in opposite directions both HL and LH ( $t_{OST}$ ). Limits are characterized and guaranteed by design @ 66 MHz.

**Note 2:** Pin transition skew is the absolute difference between HIGH-to-LOW and LOW-to-HIGH propagation delay, measured at a given output pin.

**Note 3:** Refer to Minimum Skew Parameters Measurement Information Chart for definitions of each skew specification.

**Note 4:** Load capacitance includes the test jig.

## Timing Diagrams

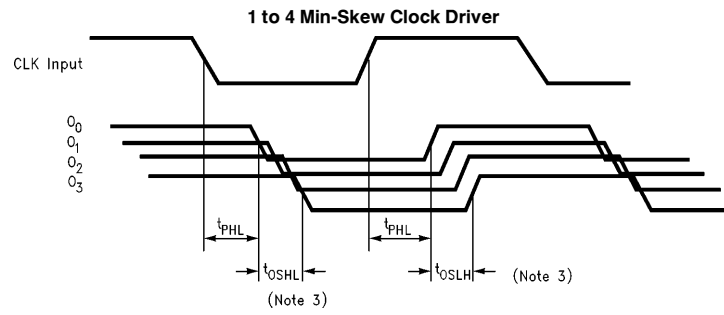

TL/F/11956-5

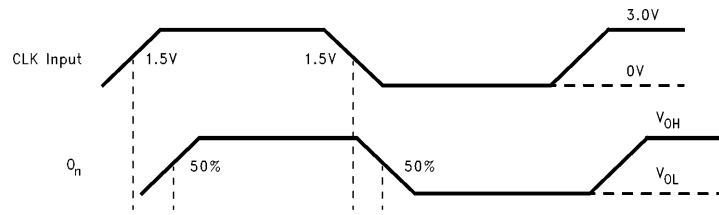

TL/F/11956-6

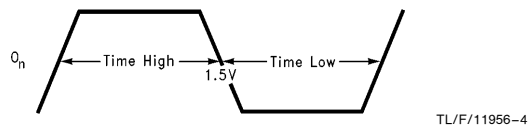

TL/F/11956-4

## Test Circuit

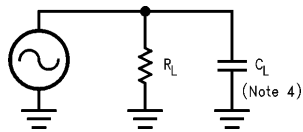

TL/F/11956-7

$R_L$  is 500 $\Omega$

$C_L$  is 50 pF for all propagation delays and skew measurements.

**Ordering Information** (Contact NSC Marketing for specific date of availability)

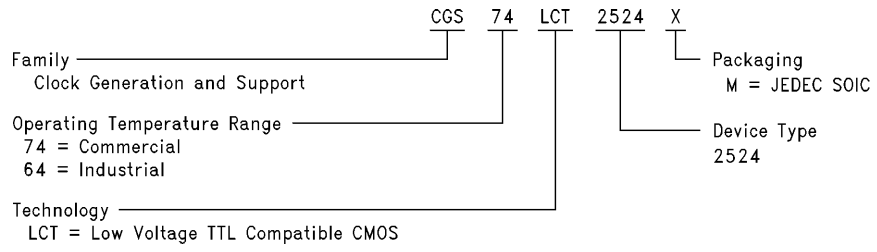

TL/F/11956-8

**Physical Dimensions** inches (millimeters) unless otherwise noted

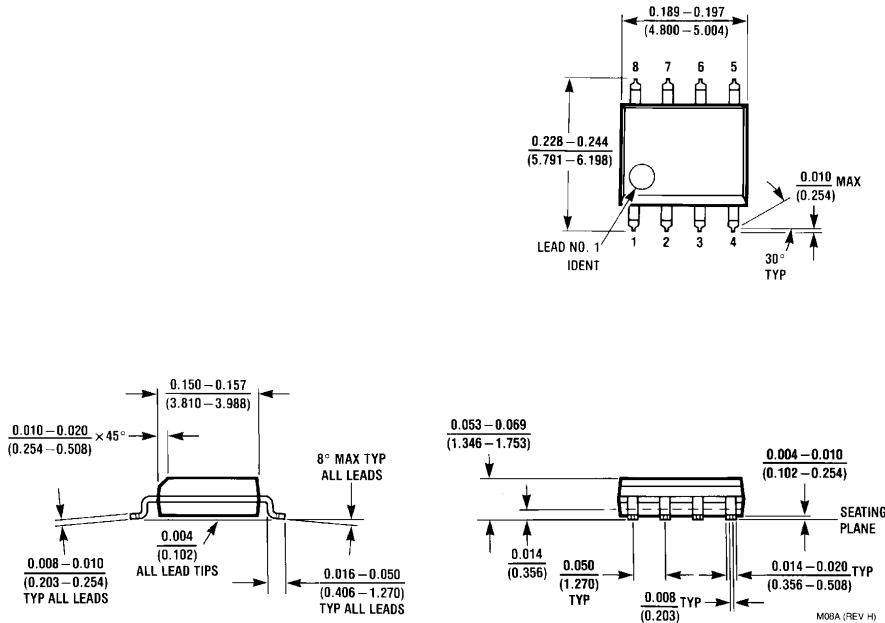

**8-Lead (0.150" Wide) Molded Small Outline Package, JEDEC**  
**Order Number CGS74LCT2524M**  
**NS Package Number M08A**

**LIFE SUPPORT POLICY**

NATIONAL'S PRODUCTS ARE NOT AUTHORIZED FOR USE AS CRITICAL COMPONENTS IN LIFE SUPPORT DEVICES OR SYSTEMS WITHOUT THE EXPRESS WRITTEN APPROVAL OF THE PRESIDENT OF NATIONAL SEMICONDUCTOR CORPORATION. As used herein:

1. Life support devices or systems are devices or systems which, (a) are intended for surgical implant into the body, or (b) support or sustain life, and whose failure to perform, when properly used in accordance with instructions for use provided in the labeling, can be reasonably expected to result in a significant injury to the user.
2. A critical component is any component of a life support device or system whose failure to perform can be reasonably expected to cause the failure of the life support device or system, or to affect its safety or effectiveness.



**National Semiconductor Corporation**  
 1111 West Bardin Road  
 Arlington, TX 76017  
 Tel: (800) 272-9959  
 Fax: (800) 737-7018

<http://www.national.com>

**National Semiconductor Europe**

Fax: +49 (0) 180-530 85 86  
 Email: [europe.support@nsc.com](mailto:europe.support@nsc.com)  
 Deutsch Tel: +49 (0) 180-530 85 85  
 English Tel: +49 (0) 180-532 78 32  
 Français Tel: +49 (0) 180-532 93 58  
 Italiano Tel: +49 (0) 180-534 16 80

**National Semiconductor Hong Kong Ltd.**

19th Floor, Straight Block,  
 Ocean Centre, 5 Canton Rd.  
 Tsimshatsui, Kowloon  
 Hong Kong  
 Tel: (852) 2737-1600  
 Fax: (852) 2736-9960

**National Semiconductor Japan Ltd.**

Tel: 81-043-299-2308  
 Fax: 81-043-299-2408

National does not assume any responsibility for use of any circuitry described, no circuit patent licenses are implied and National reserves the right at any time without notice to change said circuitry and specifications.

This datasheet has been download from:

[www.datasheetcatalog.com](http://www.datasheetcatalog.com)

Datasheets for electronics components.