

T-46-23-14



Integrated Device Technology, Inc.

**HIGH-SPEED
16K x 8 DUAL-PORT
STATIC RAM**

**PRELIMINARY
IDT7006S/L**

FEATURES:

- True dual-ported memory cells which allow simultaneous reads of the same memory location
- High-speed access
 - Military: 45/55/70ns (max.)
 - Commercial: 35/45/55ns (max.)
- Low-power operation
 - IDT7006S
Active: 500mW (typ.)
Standby: 5mW (typ.)
 - IDT7006L
Active: 500mW (typ.)
Standby: 1mW (typ.)
- IDT7006 easily expands data bus width to 16 bits or more using the Master/Slave select when cascading more than one device
- M/S = H for BUSY output flag on Master

- M/S = L for BUSY input on Slave
- Interrupt Flag
- On-chip port arbitration logic
- Full on-chip hardware support of semaphore signaling between ports
- Fully asynchronous operation from either port
- Battery backup operation—2V data retention
- TTL compatible, single 5V (±10%) power supply
- Available in 68-pin PGA, quad flatpack, LCC and PLCC

DESCRIPTION:

The IDT7006 is a high-speed 16K x 8 dual-port static RAM. The IDT7006 is designed to be used as a stand-alone 128K-bit dual-port RAM or as a combination MASTER/SLAVE dual-port RAM for 16-bit-or-more word systems. Using the IDT MASTER/SLAVE dual-port RAM approach in 16-bit or wider memory system applications results in full-speed, error-free

FUNCTIONAL BLOCK DIAGRAM

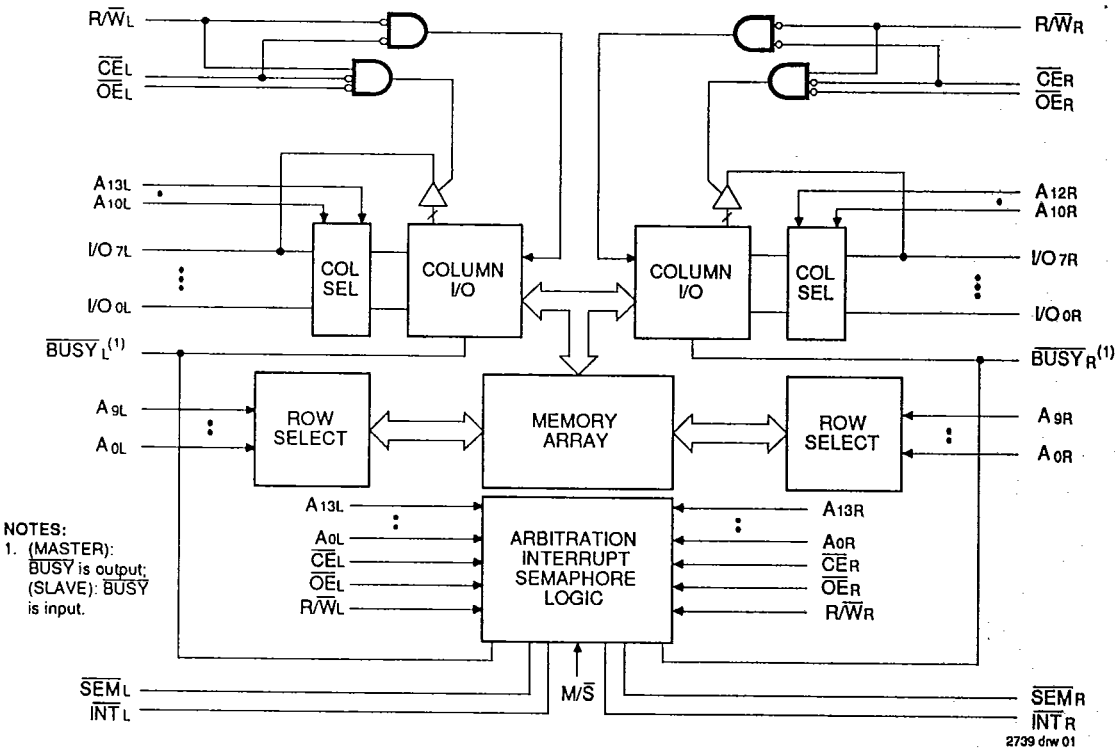

NOTES:
1. (MASTER):
BUSY is output;
(SLAVE): BUSY
is input.



2739 drw 01

CEMOS is a trademark of Integrated Device Technology, Inc.

MILITARY AND COMMERCIAL TEMPERATURE RANGES

SEPTEMBER 1990

IDT7006S/L
HIGH-SPEED 16K x 8 DUAL-PORT STATIC RAM

MILITARY AND COMMERCIAL TEMPERATURE RANGES

operation without the need for additional discrete logic.

This device provides two independent ports with separate control, address and I/O pins that permit independent, asynchronous access for reads or writes to any location in memory. An automatic power down feature controlled by \overline{CE} permits the on-chip circuitry of each port to enter a very low standby power mode.

Fabricated using IDT's CEMOS™ high-performance technology, these devices typically operate on only 500mW or

power at maximum access times as fast as 35ns. Low-power (L) versions offer battery backup data retention capability with each port typically consuming 500μW from a 2V battery.

The IDT7006 is packaged in plastic as well as ceramic 68-pin PGA and 68-pin quad flatpack, LCC and PLCC. The military devices are processed 100% in compliance to the test methods of MIL-STD-883, Method 5004.

PIN CONFIGURATIONS

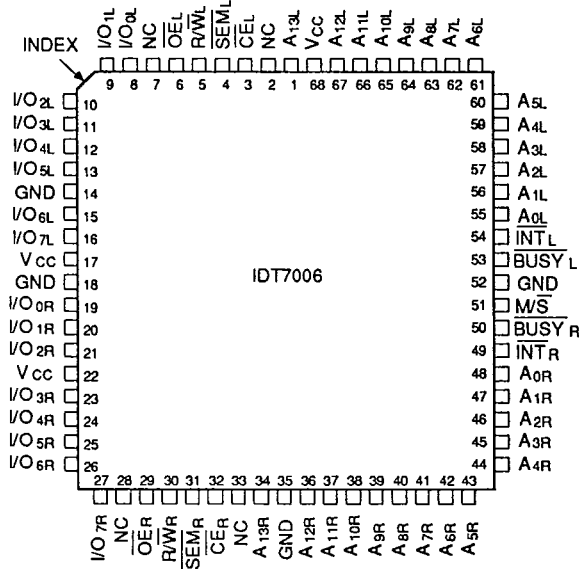

2739 drw 02

**LCC/PLCC/FLATPACK
TOP VIEW**

NOTES:

1. All Vcc pins must be connected to power supply.
2. All GND pins must be connected to ground supply.

IDT7006S/L
HIGH-SPEED 16K x 8 DUAL-PORT STATIC RAM

MILITARY AND COMMERCIAL TEMPERATURE RANGES

PIN CONFIGURATIONS (Continued)

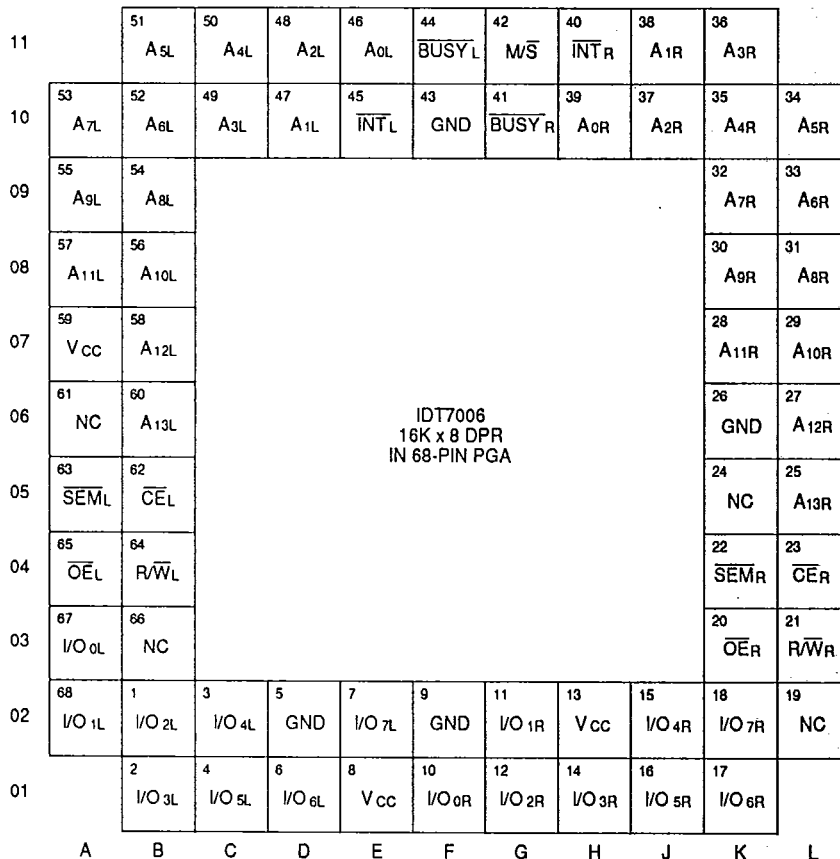

NOTES:

1. All Vcc pins must be connected to power supply.
2. All GND pins must be connected to ground supply.

68-PIN PGA
TOP VIEW

2739 drw 03

PIN NAMES

Left Port	Right Port	Names
\overline{CE}_L	\overline{CE}_R	Chip Enable
R/\overline{W}_L	R/\overline{W}_R	Read/Write Enable
\overline{OE}_L	\overline{OE}_R	Output Enable
A _{0L} - A _{13L}	A _{0R} - A _{13R}	Address
I/O _{0L} - I/O _{7L}	I/O _{0R} - I/O _{7R}	Data Input/Output
\overline{SEM}_L	\overline{SEM}_R	Semaphore Enable
\overline{INT}_L	\overline{INT}_R	Interrupt Flag
\overline{BUSY}_L	\overline{BUSY}_R	Busy Flag
M/S		Master or Slave Select
Vcc		Power
GND		Ground

2739 tbl 18

IDT7006S/L
HIGH-SPEED 16K x 8 DUAL-PORT STATIC RAM

MILITARY AND COMMERCIAL TEMPERATURE RANGES

TRUTH TABLE: NON-CONTENTION READ/WRITE CONTROL

T-46-23-14

Inputs ⁽¹⁾				Outputs	Mode
CE	R/W	OE	SEM	I/O ₀₋₇	
H	X	X	H	Hi-Z	Deselected: Power Down
L	L	X	H	DATA _{IN}	Write to Memory
L	H	L	H	DATA _{OUT}	Read Memory
X	X	H	X	Hi-Z	Outputs Disabled

NOTE: 2739 b1 01
1. A_{0L} — A_{13L} = A_{0R} — A_{13R}

TRUTH TABLE: SEMAPHORE READ/WRITE CONTROL

Inputs				Outputs	Mode
CE	R/W	OE	SEM	I/O ₀₋₇	
H	H	L	L	DATA _{OUT}	Read Data in Semaphore Flag
H		X	L	DATA _{IN}	Write D _{IN} into Semaphore Flag
L	X	X	L	—	Not Allowed

2739 b1 02

ABSOLUTE MAXIMUM RATINGS⁽¹⁾

Symbol	Rating	Commercial	Military	Unit
V _{TERM}	Terminal Voltage with Respect to GND	-0.5 to +7.0	-0.5 to +7.0	V
T _A	Operating Temperature	0 to +70	-55 to +125	°C
T _{BIAS}	Temperature Under Bias	-55 to +125	-65 to +135	°C
T _{STG}	Storage Temperature	-55 to +125	-65 to +150	°C
I _{OUT}	DC Output Current	50	50	mA

NOTE: 2739 b1 04
1. Stresses greater than those listed under ABSOLUTE MAXIMUM RATINGS may cause permanent damage to the device. This is a stress rating only and functional operation of the device at these or any other conditions above those indicated in the operational sections of this specification is not implied. Exposure to absolute maximum rating conditions for extended periods may affect reliability.

RECOMMENDED OPERATING TEMPERATURE AND SUPPLY VOLTAGE

Grade	Ambient Temperature	GND	V _{CC}
Military	-55°C to +125°C	0V	5.0V ± 10%
Commercial	0°C to +70°C	0V	5.0V ± 10%

2739 b1 05

RECOMMENDED DC OPERATING CONDITIONS

Symbol	Parameter	Min.	Typ.	Max.	Unit
V _{CC}	Supply Voltage	4.5	5.0	5.5	V
GND	Supply Voltage	0	0	0	V
V _{IH}	Input High Voltage	2.2	—	6.0	V
V _{IL}	Input Low Voltage	-0.5 ⁽¹⁾	—	0.8	V

NOTE: 2739 b1 06
1. V_{IL} ≥ -3.0V for pulse width less than 20ns.

CAPACITANCE (T_A = +25°C, f = 1.0MHz)

Symbol	Parameter ⁽¹⁾	Conditions	Max.	Unit
C _{IN}	Input Capacitance	V _{IN} = 0V	11	pF
C _{OUT}	Output Capacitance	V _{OUT} = 0V	11	pF

NOTE: 2739 b1 03
1. This parameter is determined by device characterization but is not production tested.

DC ELECTRICAL CHARACTERISTICS OVER THE OPERATING TEMPERATURE AND SUPPLY VOLTAGE RANGE ($V_{CC} = 5.0V \pm 10\%$)

Symbol	Parameter	Test Conditions	IDT7006S		IDT7006L		Unit
			Min.	Max.	Min.	Max.	
I _{LI}	Input Leakage Current ⁽⁵⁾	$V_{CC} = 5.5V, V_{IN} = 0V \text{ to } V_{CC}$	—	10	—	5	μA
I _{LO}	Output Leakage Current	$\overline{CE} = V_{IH}, V_{OUT} = 0V \text{ to } V_{CC}$	—	10	—	5	μA
V _{OL}	Output Low Voltage	$I_{OL} = 4mA$	—	0.4	—	0.4	V
V _{OH}	Output High Voltage	$I_{OH} = -4mA$	2.4	—	2.4	—	V

2739 bl 07

DC ELECTRICAL CHARACTERISTICS OVER THE OPERATING TEMPERATURE AND SUPPLY VOLTAGE RANGE⁽¹⁾ ($V_{CC} = 5.0V \pm 10\%$)

Symbol	Parameter	Test Condition	Version	7006X35 COM'L ONLY		Unit
				Typ. ⁽²⁾	Max.	
I _{CC}	Dynamic Operating Current (Both Ports Active)	$\overline{CE} \leq V_{IL}, \text{Outputs Open}$ $\overline{SEM} \geq V_{IH}$ $f = f_{MAX}^{(3)}$	MIL. S	—	—	mA
			L	—	—	
I _{SB1}	Standby Current (Both Ports — TTL Level Inputs)	$\overline{CE}_R = \overline{CE}_L \geq V_{IH}$ $\overline{SEM}_R = \overline{SEM}_L \geq V_{IH}$ $f = f_{MAX}^{(3)}$	COM'L. S	—	340	mA
			L	—	290	
I _{SB2}	Standby Current (One Port — TTL Level Inputs)	$\overline{CE}_L \text{ or } \overline{CE}_R \geq V_{IH}$ Active Port Outputs Open $f = f_{MAX}^{(3)}$ $\overline{SEM}_R = \overline{SEM}_L \geq V_{IH}$	MIL. S	—	—	mA
			L	—	—	
I _{SB3}	Full Standby Current (Both Ports — All CMOS Level Inputs)	Both Ports \overline{CE}_L and $\overline{CE}_R \geq V_{CC} - 0.2V$ $V_{IN} \geq V_{CC} - 0.2V$ or $V_{IN} \leq 0.2V, f = 0^{(4)}$ $\overline{SEM}_R = \overline{SEM}_L \geq V_{CC} - 0.2V$	COM'L. S	—	240	mA
			L	—	210	
I _{SB4}	Full Standby Current (One Port — All CMOS Level Inputs)	One Port \overline{CE}_L or $\overline{CE}_R \geq V_{CC} - 0.2V$ $\overline{SEM}_R = \overline{SEM}_L \geq V_{CC} - 0.2V$ $V_{IN} \geq V_{CC} - 0.2V$ or $V_{IN} \leq 0.2V$ Active Port Outputs Open, $f = f_{MAX}^{(3)}$	MIL. S	—	—	mA
			L	—	—	
			COM'L. S	—	220	mA
			L	—	180	



NOTES:

- X in part numbers indicates power rating (S or L)
- $V_{CC} = 5V, T_A = +25^\circ C$.
- At $f = f_{MAX}$, address and data inputs (except Output Enable) are cycling at the maximum frequency of read cycle of $1/t_{RC}$, and using "AC Test Conditions" of input levels of GND to 3V.
- $f = 0$ means no address or control lines change.
- At $V_{CC} \leq 1.0V$ input leakages are undefined.

2739 bl 08

DC ELECTRICAL CHARACTERISTICS OVER THE OPERATING TEMPERATURE AND SUPPLY VOLTAGE RANGE⁽¹⁾ (Continued) (V_{CC} = 5.0V ± 10%)

Symbol	Parameter	Test Condition	Version	7006X45		7006X55		7006X70 MIL ONLY		Unit		
				Typ. ⁽²⁾	Max.	Typ. ⁽²⁾	Max.	Typ. ⁽²⁾	Max.			
I _{CC}	Dynamic Operating Current (Both Ports Active)	$\overline{CE} \leq V_{IL}$, Outputs Open $SEMR \geq V_{IH}$ $f = f_{MAX}^{(3)}$	MIL.	S	—	400	—	395	—	390	mA	
				L	—	340	—	335	—	330		
			COM'L.	S	—	340	—	335	—	—		—
				L	—	290	—	285	—	—		—
I _{SB1}	Standby Current (Both Ports — TTL Level Inputs)	$\overline{CE}_L = \overline{CE}_R \geq V_{IH}$ $SEMR = SEM_L \geq V_{IH}$ $f = f_{MAX}^{(3)}$	MIL.	S	—	85	—	85	—	85	mA	
				L	—	65	—	65	—	65		
			COM'L.	S	—	70	—	70	—	—		—
				L	—	50	—	50	—	—		—
I _{SB2}	Standby Current (One Port — TTL Level Inputs)	\overline{CE}_R or $\overline{CE}_L \geq V_{IH}$ Active Port Outputs Open $f = f_{MAX}^{(3)}$ $SEMR = SEM_L \geq V_{IH}$	MIL.	S	—	290	—	290	—	290	mA	
				L	—	250	—	250	—	250		
			COM'L.	S	—	240	—	240	—	—		—
				L	—	210	—	210	—	—		—
I _{SB3}	Full Standby Current (Both Ports — All CMOS Level Inputs)	Both Ports \overline{CE}_L and $\overline{CE}_R \geq V_{CC} - 0.2V$ $V_{IN} \geq V_{CC} - 0.2V$ or $V_{IN} \leq 0.2V$, $f = 0^{(4)}$ $SEMR = SEM_L \geq V_{CC} - 0.2V$	MIL.	S	—	30	—	30	—	30	mA	
				L	—	10	—	10	—	10		
			COM'L.	S	—	15	—	15	—	—		—
				L	—	5	—	5	—	—		—
I _{SB4}	Full Standby Current (One Port — All CMOS Level Inputs)	One Port \overline{CE}_L or $\overline{CE}_R \geq V_{CC} - 0.2V$ $SEMR = SEM_L \geq V_{CC} - 0.2V$ $V_{IN} \geq V_{CC} - 0.2V$ or $V_{IN} \leq 0.2V$ Active Port Outputs Open, $f = f_{MAX}^{(3)}$	MIL.	S	—	260	—	260	—	260	mA	
				L	—	215	—	215	—	215		
			COM'L.	S	—	220	—	220	—	—		—
				L	—	180	—	180	—	—		—

NOTES:

- X in part numbers indicates power rating (S or L)
- V_{CC} = 5V, T_A = +25°C.
- At f = f_{MAX}, address and data inputs (except Output Enable) are cycling at the maximum frequency of read cycle of 1/10T_{RC}, and using "AC Test Conditions" of input levels of GND to 3V.
- f = 0 means no address or control lines change.
- At V_{CC} ≤ 1.0V input leakages are undefined.

2739 b1 08

DATA RETENTION CHARACTERISTICS OVER ALL TEMPERATURE RANGES (L Version Only)
(VLC = 0.2V, VHC = VCC - 0.2V)

Symbol	Parameter	Test Condition	Min.	Typ. ⁽¹⁾	Max.	Unit
VDR	Vcc for Data Retention	VCC = 2V	2.0	—	—	V
ICCDR	Data Retention Current	$\overline{CE} \geq V_{HC}$ $V_{IN} \geq V_{HC}$ or $\leq V_{LC}$	MIL.	—	4000	μA
			COM'L.	—	1500	
tCDR ⁽³⁾	Chip Deselect to Data Retention Time		0	—	—	ns
tR ⁽³⁾	Operation Recovery Time		tRC ⁽²⁾	—	—	ns

- NOTES:
 1. TA = +25°C, VCC = 2V
 2. tRC = Read Cycle Time
 3. This parameter is guaranteed but not tested.

2739 tbl 09

DATA RETENTION WAVEFORM

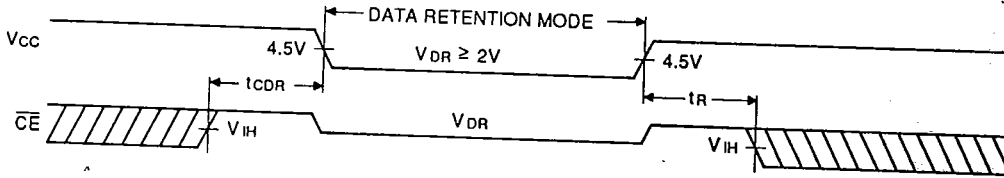

2739 drw 04

AC TEST CONDITIONS

Input Pulse Levels	GND to 3.0V
Input Rise/Fall Times	5ns Max.
Input Timing Reference Levels	1.5V
Output Reference Levels	1.5V
Output Load	See Figures 1 & 2

2739 tbl 10

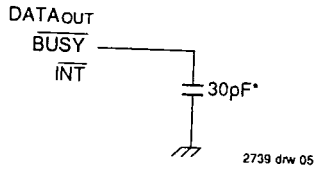

Figure 1. Output Load

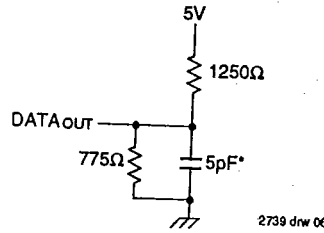

Figure 2. Output Load
(for tLZ, tHZ, tWZ, tOW)

* Including scope and jig.

IDT7006S/L
HIGH-SPEED 16K x 8 DUAL-PORT STATIC RAM

MILITARY AND COMMERCIAL TEMPERATURE RANGES

AC ELECTRICAL CHARACTERISTICS OVER THE
OPERATING TEMPERATURE AND SUPPLY VOLTAGE RANGE⁽⁴⁾

T-46-23-14

Symbol	Parameter	IDT7006X35 COM'L ONLY		Unit
		Min.	Max.	
READ CYCLE				
IRC	Read Cycle Time	35	—	ns
IAA	Address Access Time	—	35	ns
IACE	Chip Enable Access Time ⁽³⁾	—	35	ns
IAOE	Output Enable Access Time	—	20	ns
IOH	Output Hold from Address Change	3	—	ns
ILZ	Output Low Z Time ^(1, 2)	3	—	ns
IHZ	Output High Z Time ^(1, 2)	—	15	ns
IPU	Chip Enable to Power Up Time ⁽²⁾	0	—	ns
IPD	Chip Disable to Power Down Time ⁽²⁾	—	50	ns
ISOP	Semaphore Flag Update Pulse (\overline{OE} or \overline{SEM})	15	—	ns

Symbol	Parameter	IDT7006X45		IDT7006X55		IDT7006X70 MIL ONLY		Unit
		Min.	Max.	Min.	Max.	Min.	Max.	
READ CYCLE								
IRC	Read Cycle Time	45	—	55	—	70	—	ns
IAA	Address Access Time	—	45	—	55	—	70	ns
IACE	Chip Enable Access Time ⁽³⁾	—	45	—	55	—	70	ns
IAOE	Output Enable Access Time	—	25	—	30	—	35	ns
IOH	Output Hold from Address Change	3	—	3	—	3	—	ns
ILZ	Output Low Z Time ^(1, 2)	5	—	5	—	5	—	ns
IHZ	Output High Z Time ^(1, 2)	—	20	—	25	—	30	ns
IPU	Chip Enable to Power Up Time ⁽²⁾	0	—	0	—	0	—	ns
IPD	Chip Disable to Power Down Time ⁽²⁾	—	50	—	50	—	50	ns
ISOP	Semaphore Flag Update Pulse (\overline{OE} or \overline{SEM})	15	—	15	—	15	—	ns

NOTES:

1. Transition is measured $\pm 500\text{mV}$ from low or high impedance voltage with load (Figures 1 and 2).
2. This parameter is guaranteed but not tested.
3. To access RAM, $\overline{CE} = L$, $\overline{SEM} = H$.
4. X in part numbers indicates power rating (S or L).

2799 b1 11

IDT7006S/L
HIGH-SPEED 16K x 8 DUAL-PORT STATIC RAM

MILITARY AND COMMERCIAL TEMPERATURE RANGES

WAVEFORM OF READ CYCLES⁽⁵⁾

T-46-23-14

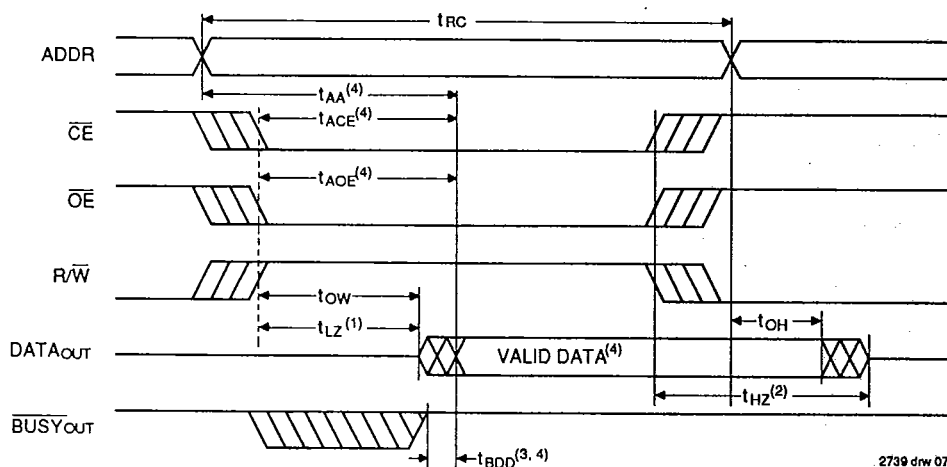

2739 drw 07

NOTES:

1. Timing depends on which signal is asserted last, \overline{OE} or \overline{CE} .
2. Timing depends on which signal is de-asserted first \overline{CE} or \overline{OE} .
3. Required only if busy logic is being used to prevent read data corruption, during simultaneous accesses to the same location, in masters and master-slave width expansions.
4. Start of valid data depends on which timing becomes effective last t_{ABE} , t_{AOE} , t_{ACE} , t_{AA} or t_{BDD} .
5. $\overline{SEM} = H$.

TIMING OF POWER-UP POWER-DOWN

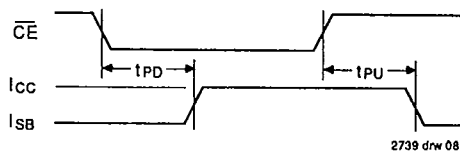

2739 drw 08

AC ELECTRICAL CHARACTERISTICS OVER THE OPERATING TEMPERATURE AND SUPPLY VOLTAGE ⁽⁵⁾

Symbol	Parameter	IDT7006X35		Unit
		Min.	Max.	
WRITE CYCLE				
tWC	Write Cycle Time	35	—	ns
tEW	Chip Enable to End of Write ⁽³⁾	30	—	ns
tAW	Address Valid to End of Write	30	—	ns
tAS	Address Set-up Time ⁽³⁾	0	—	ns
tWP	Write Pulse Width	30	—	ns
tWR	Write Recovery Time	0	—	ns
tDW	Data Valid to End of Write	25	—	ns
tHZ	Output High Z Time ^(1, 2)	—	15	ns
tDH	Data Hold Time ⁽⁴⁾	0	—	ns
tWZ	Write Enable to Output in High Z ^(1, 2)	—	15	ns
tOW	Output Active from End of Write ^(1, 2, 4)	0	—	ns
tSWRD	SEM Flag Write to Read Time	10	—	ns
tSPS	SEM Flag Contention Window	10	—	ns

Symbol	Parameter	IDT7006X45		IDT7006X55		IDT7006X70 MIL. ONLY		Unit
		Min.	Max.	Min.	Max.	Min.	Max.	
WRITE CYCLE								
tWC	Write Cycle Time	45	—	55	—	70	—	ns
tEW	Chip Enable to End of Write ⁽³⁾	40	—	45	—	50	—	ns
tAW	Address Valid to End of Write	40	—	45	—	50	—	ns
tAS	Address Set-up Time ⁽³⁾	0	—	0	—	0	—	ns
tWP	Write Pulse Width	35	—	40	—	50	—	ns
tWR	Write Recovery Time	0	—	0	—	0	—	ns
tDW	Data Valid to End of Write	25	—	30	—	40	—	ns
tHZ	Output High Z Time ^(1, 2)	—	20	—	25	—	30	ns
tDH	Data Hold Time ⁽⁴⁾	0	—	0	—	0	—	ns
tWZ	Write Enable to Output in High Z ^(1, 2)	—	20	—	25	—	30	ns
tOW	Output Active from End of Write ^(1, 2, 4)	0	—	0	—	0	—	ns
tSWRD	SEM Flag Write to Read Time	10	—	10	—	10	—	ns
tSPS	SEM Flag Contention Window	10	—	10	—	10	—	ns

- NOTES:**
1. Transition is measured $\pm 500\text{mV}$ from low or high impedance voltage with load (Figures 1 and 2).
 2. This parameter is guaranteed but not tested.
 3. To access RAM, $\overline{\text{CE}} = \text{L}$, $\overline{\text{SEM}} = \text{H}$. To access semaphore, $\overline{\text{CE}} = \text{H}$ and $\overline{\text{SEM}} = \text{L}$. Either condition must be valid for the entire tEW time.
 4. The specification for tDH must be met by the device supplying write data to the RAM under all operating conditions. Although tDH and tOW values will vary over voltage and temperature, the actual tDH will always be smaller than the actual tOW.
 5. X in part numbers indicates power rating (S or L).

2739 b1 12

TIMING WAVEFORM OF WRITE CYCLE NO. 1, R/W CONTROLLED TIMING^(1,3,5,8)

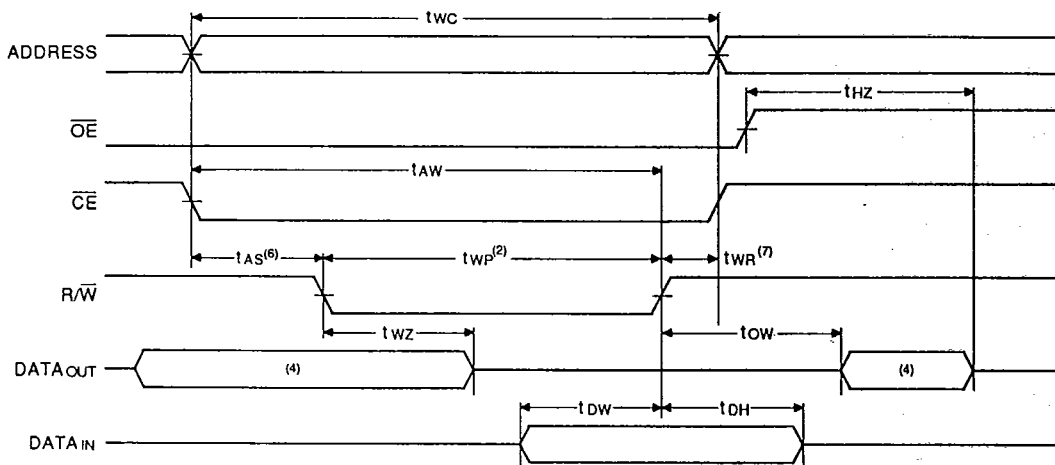

2739 drw 09

TIMING WAVEFORM OF WRITE CYCLE NO. 2, CE CONTROLLED TIMING^(1,3,5,8)

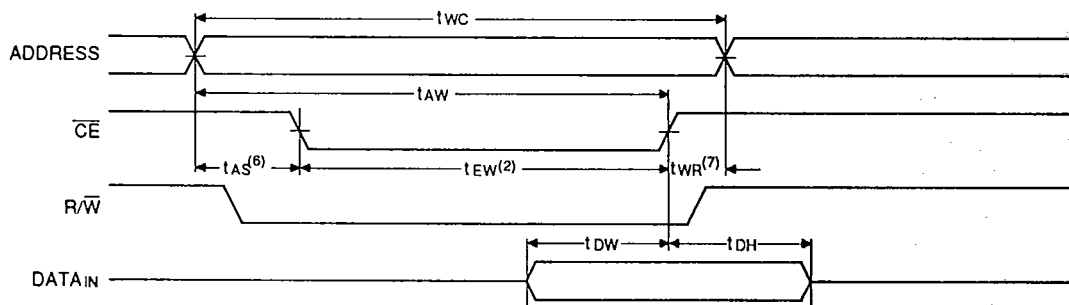

2739 drw 10

NOTES:

1. R/W must be high during all address transitions.
2. A write occurs during the overlap (tEW or tWP) of a low CE and a low R/W for memory array writing cycle.
3. tWR is measured from the earlier of CE or R/W (or SEM or R/W) going high to the end of write cycle.
4. During this period, the I/O pins are in the output state and input signals must not be applied.
5. If the CE or SEM low transition occurs simultaneously with or after the R/W low transition, the outputs remain in the high impedance state.
6. Timing depends on which enable signal is asserted last.
7. Timing depends on which enable signal is de-asserted first.
8. If OE is low during R/W controlled write cycle, the write pulse width must be the larger of tWP or (tWZ + tOW) to allow the I/O drivers to turn off and data to be placed on the bus for the required tDW. If OE is high during an R/W controlled write cycle, this requirement does not apply and the write pulse can be as short as the specified tWP.



TIMING WAVEFORM OF SEMAPHORE READ AFTER WRITE TIMING, EITHER SIDE⁽¹⁾

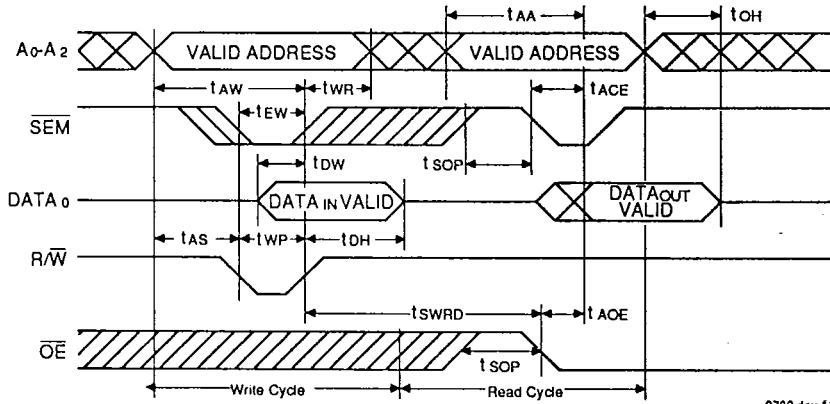

2739 drw 11

NOTE:

1. $\overline{CE} = H$ for the duration of the above timing (both write and read cycle).

TIMING WAVEFORM OF SEMAPHORE WRITE CONTENTION^(1,3,4)

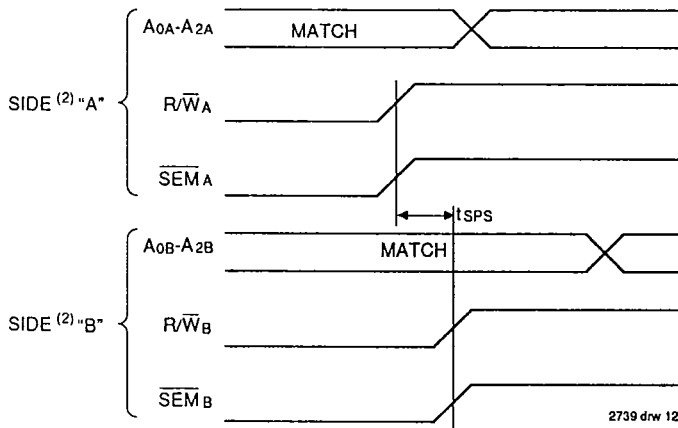

2739 drw 12

NOTES:

1. $D_{0A} = D_{0L} = L$, $\overline{CE}_A = \overline{CE}_L = H$, Semaphore Flag is released from both sides (reads as ones from both sides) at cycle start.
2. "A" may be either left or right port. "B" is the opposite port from "A".
3. This parameter is measured from R/\overline{W}_A or \overline{SEM}_A going high to R/\overline{W}_B or \overline{SEM}_B going high.
4. If t_{SPS} is violated, the semaphore will fall positively to one side or the other, but there is not guarantee which side will obtain the flag.

IDT7006S/L
HIGH-SPEED 16K x 8 DUAL-PORT STATIC RAM

MILITARY AND COMMERCIAL TEMPERATURE RANGES

AC ELECTRICAL CHARACTERISTICS OVER THE OPERATING TEMPERATURE AND SUPPLY VOLTAGE RANGE⁽⁶⁾

Symbol	Parameter	IDT7006X35 COM'L ONLY		Unit
		Min.	Max.	
BUSY TIMING (M\bar{S} = H)				
tBAA	\overline{BUSY} Access Time to Address	—	35	ns
tBDA	\overline{BUSY} Disable Time to Address	—	30	ns
tBAC	\overline{BUSY} Access Time to Chip Enable	—	30	ns
tBDC	\overline{BUSY} Disable Time to Chip Enable	—	25	ns
tAPS	Arbitration Priority Set-up Time ⁽²⁾	5	—	ns
tBDD	\overline{BUSY} Disable to Valid Data ⁽⁵⁾	—	Note 3	ns
BUSY TIMING (M\bar{S} = L)				
tWB	\overline{BUSY} Input to Write ⁽⁴⁾	0	—	ns
tWH	Write Hold After \overline{BUSY} ⁽⁵⁾	25	—	ns
PORT-TO-PORT DELAY TIMING				
tWDD	Write Pulse to Data Delay ⁽⁷⁾	—	60	ns
tDDD	Write Data Valid to Read Data Delay ⁽⁷⁾	—	45	ns

Symbol	Parameter	IDT7006X45		IDT7006X55		IDT7006X70 MIL. ONLY		Unit
		Min.	Max.	Min.	Max.	Min.	Max.	
BUSY TIMING (M\bar{S} = H)								
tBAA	\overline{BUSY} Access Time to Address	—	35	—	45	—	45	ns
tBDA	\overline{BUSY} Disable Time to Address	—	30	—	40	—	40	ns
tBAC	\overline{BUSY} Access Time to Chip Enable	—	30	—	40	—	40	ns
tBDC	\overline{BUSY} Disable Time to Chip Enable	—	25	—	35	—	35	ns
tAPS	Arbitration Priority Set-up Time ⁽²⁾	5	—	5	—	5	—	ns
tBDD	\overline{BUSY} Disable to Valid Data ⁽⁵⁾	—	Note 3	—	Note 3	—	Note 3	ns
BUSY TIMING (M\bar{S} = L)								
tWB	\overline{BUSY} Input to Write ⁽⁴⁾	0	—	0	—	0	—	ns
tWH	Write Hold After \overline{BUSY} ⁽⁵⁾	25	—	25	—	25	—	ns
PORT-TO-PORT DELAY TIMING								
tWDD	Write Pulse to Data Delay ⁽⁷⁾	—	70	—	80	—	95	ns
tDDD	Write Data Valid to Read Data Delay ⁽⁷⁾	—	55	—	65	—	80	ns

NOTES:

1. Port-to-port delay through RAM cells from writing port to reading port, refer to "Timing Waveform of Read With \overline{BUSY} (M \bar{S} = H)".
2. To ensure that the earlier of the two ports wins.
3. tBDD is a calculated parameter and is the greater of 0, tWDD - tWP (actual) or tDDD - tDW (actual).
4. To ensure that the write cycle is inhibited during contention.
5. To ensure that a write cycle is completed after contention.
6. "x" is part numbers indicates power rating (S or L).
7. Port-to-port delay through RAM cells from writing port to reading port, refer to "Timing Waveform of Read With \overline{BUSY} (M \bar{S} = L)".

2739 13

TIMING WAVEFORM OF READ WITH $\overline{\text{BUSY}}^{(2)}$ ($M/\overline{S} = H$)

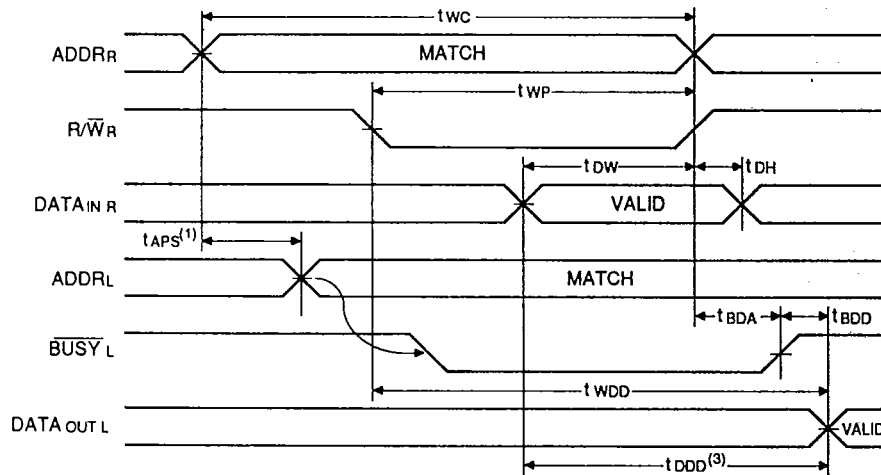

- NOTES:**
 1. To ensure that the earlier of the two ports wins.
 2. $\overline{\text{CEL}} = \overline{\text{CER}} = L$
 3. $\overline{\text{OE}} = L$ for the reading port.

2739 drw 13

TIMING WAVEFORM OF WRITE WITH PORT-TO-PORT DELAY^(1,2) ($M/\overline{S} = L$)

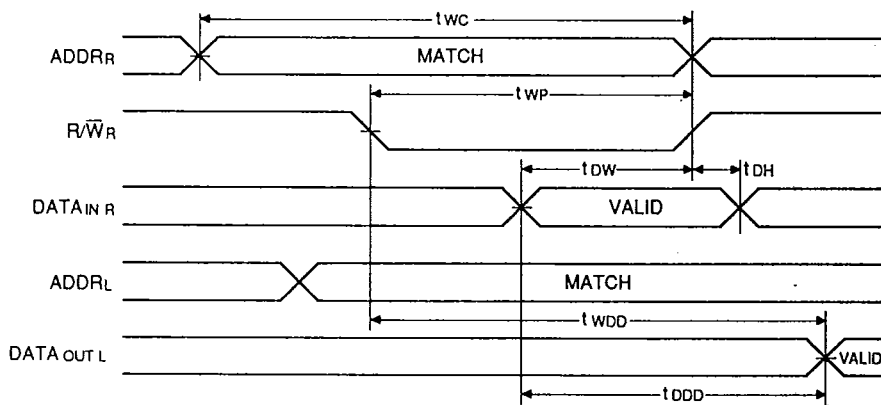

- NOTES:**
 1. $\overline{\text{BUSY}}$ input equals H for the writing port.
 2. $\overline{\text{CEL}} = \overline{\text{CER}} = L$

2739 drw 14

TIMING WAVEFORM OF SLAVE WRITE ($M/\overline{S} = L$)

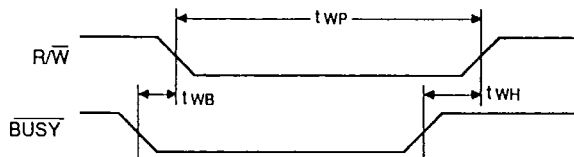

2739 drw 15

WAVEFORM OF BUSY ARBITRATION CONTROLLED BY \overline{CE} TIMING⁽¹⁾ ($M/\overline{S} = H$)

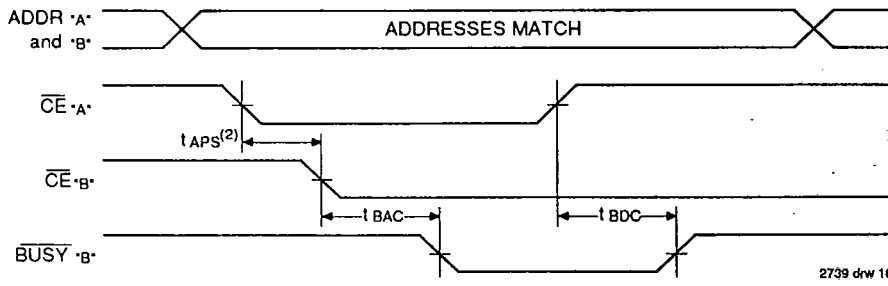

WAVEFORM OF BUSY ARBITRATION CYCLE CONTROLLED BY ADDRESS MATCH TIMING⁽¹⁾ ($M/\overline{S} = H$)

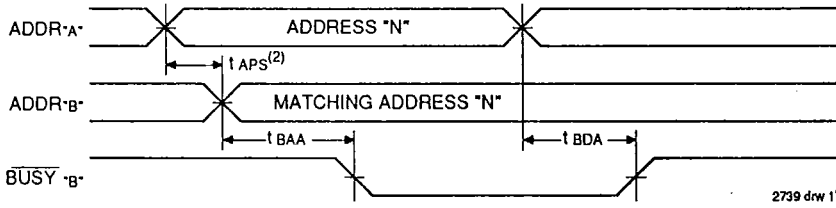

NOTES:

1. All timing is the same for left and right ports. Port "A" may be either the left or right port. Port "B" is the port opposite from "A".
2. If tAPS is violated, the busy signal will be asserted on one side or another but there is no guarantee on which side busy will be asserted.



AC ELECTRICAL CHARACTERISTICS OVER THE OPERATING TEMPERATURE AND SUPPLY VOLTAGE RANGE⁽¹⁾

Symbol	Parameter	IDT7006X35 COM'L ONLY		Unit
		Min.	Max.	
INTERRUPT TIMING				
tAS	Address Set-up Time	0	—	ns
tWR	Write Recovery Time	0	—	ns
tINS	Interrupt Set Time	—	30	ns
tINR	Interrupt Reset Time	—	30	ns

Symbol	Parameter	IDT7006X45		IDT7006X55		IDT7006X70 MIL. ONLY		Unit
		Min.	Max.	Min.	Max.	Min.	Max.	
INTERRUPT TIMING								
tAS	Address Set-up Time	0	—	0	—	0	—	ns
tWR	Write Recovery Time	0	—	0	—	0	—	ns
tINS	Interrupt Set Time	—	35	—	40	—	50	ns
tINR	Interrupt Reset Time	—	35	—	40	—	50	ns

NOTE:
1. "x" in part numbers indicates power rating (S or L). 2739 tbl 14

WAVEFORM OF INTERRUPT TIMING⁽¹⁾

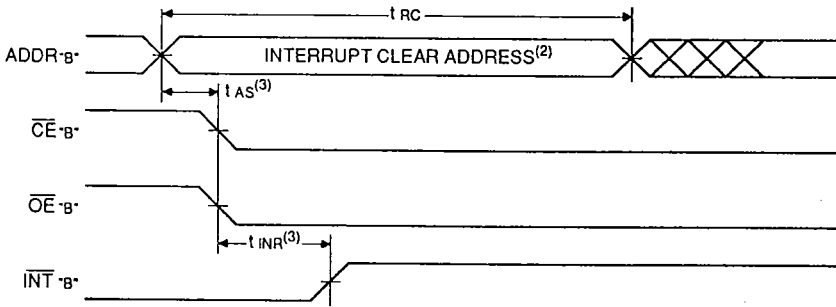
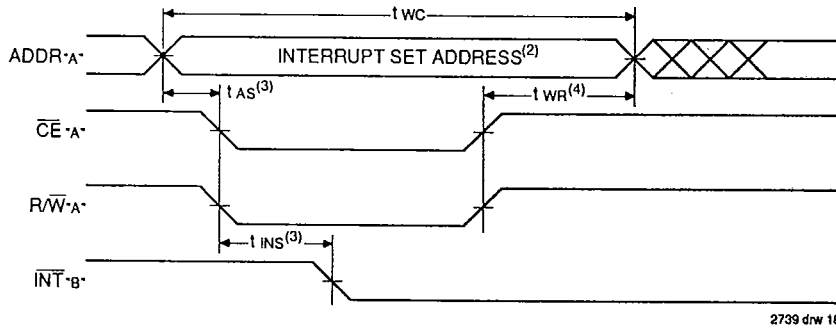

- NOTES:
1. All timing is the same for left and right ports. Port "A" may be either the left or right port. Port "B" is the port opposite from "A".
 2. See Interrupt truth table.
 3. Timing depends on which enable signal is asserted last.
 4. Timing depends on which enable signal is de-asserted first.

TRUTH TABLES

TRUTH TABLE I — INTERRUPT FLAG⁽¹⁾

Left Port					Right Port					Function	
R/WL	CE _L	OE _L	A _{0L} -A _{13L}	INT _L	R/W _R	CE _R	OE _R	A _{0R} -A _{13R}	INT _R		
L	L	X	3FFF	X	X	X	X	X	X	L ⁽²⁾	Set Right INT _R Flag
X	X	X	X	X	X	L	L	3FFF	H ⁽³⁾		Reset Right INT _R Flag
X	X	X	X	L ⁽³⁾	L	L	X	3FFE	X		Set Left INT _L Flag
X	L	L	3FFE	H ⁽²⁾	X	X	X	X	X		Reset Left INT _L Flag

NOTES:

1. Assumes $\overline{BUSY}_L = \overline{BUSY}_R = H$.
2. If $\overline{BUSY}_L = L$, then no change.
3. If $\overline{BUSY}_R = L$, then no change.

2739 16 15

TRUTH TABLE II — ADDRESS BUSY ARBITRATION

Inputs			Outputs		Function
CE _L	CE _R	A _{0L} -A _{13L} A _{0R} -A _{13R}	\overline{BUSY}_L ⁽¹⁾	\overline{BUSY}_R ⁽¹⁾	
X	X	NO MATCH	H	H	Normal
H	X	MATCH	H	H	Normal
X	H	MATCH	H	H	Normal
L	L	MATCH	(2)	(2)	Write Inhibit ⁽³⁾

NOTES:

1. Pins \overline{BUSY}_L and \overline{BUSY}_R are both outputs when the part is configured as a master. Both are inputs when configured as a slave. \overline{BUSY}_X outputs on the IDT7006 are push pull, not open drain outputs. On slaves the \overline{BUSY}_X input internally inhibits writes.
2. L if the inputs to the opposite port were stable prior to the address and enable inputs of this port. H if the inputs to the opposite port became stable after the address and enable inputs of this port. If taps is not met, either \overline{BUSY}_L or $\overline{BUSY}_R = Low$ will result. \overline{BUSY}_L and \overline{BUSY}_R outputs cannot be low simultaneously.
3. Writes to the left port are internally ignored when \overline{BUSY}_L outputs are driving low regardless of actual logic level on the pin. Writes to the right port are internally ignored when \overline{BUSY}_R outputs are driving low regardless of actual logic level on the pin.

2739 16 16

TRUTH TABLE III — EXAMPLE OF SEMAPHORE PROCUREMENT SEQUENCE⁽¹⁾

Functions	D ₀ - D ₇ Left	D ₀ - D ₇ Right	Status
No Action	1	1	Semaphore free
Left Port Writes "0" to Semaphore	0	1	Left port has semaphore token
Right Port Writes "0" to Semaphore	0	1	No change. Right side has no write access to semaphore
Left Port Writes "1" to Semaphore	1	0	Right port obtains semaphore token
Left Port Writes "0" to Semaphore	1	0	No change. Left port has no write access to semaphore
Right Port Writes "1" to Semaphore	0	1	Left port obtains semaphore token
Left Port Writes "1" to Semaphore	1	1	Semaphore free
Right Port Writes "0" to Semaphore	1	0	Right port has semaphore token
Right Port Writes "1" to Semaphore	1	1	Semaphore free
Left Port Writes "0" to Semaphore	0	1	Right port has semaphore token
Left Port Writes "1" to Semaphore	1	1	Semaphore free

NOTE:

1. This table denotes a sequence of events for only one of the eight semaphores on the IDT7006.

2739 17 17

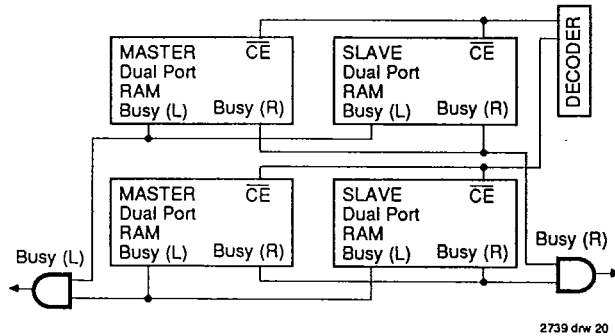

Figure 3. Busy and chip enable routing for both width and depth expansion with IDT7006 RAMs.

FUNCTIONAL DESCRIPTION

The IDT7006 provides two ports with separate control, address and I/O pins that permit independent access for reads or writes to any location in memory. The IDT7006 has an automatic power down feature controlled by \overline{CE} . The \overline{CE} controls on-chip power down circuitry that permits the respective port to go into a standby mode when not selected (\overline{CE} high). When a port is enabled, access to the entire memory array is permitted.

INTERRUPTS

If the user chooses to use the interrupt function, a memory location (mail box or message center) is assigned to each port. The left port interrupt flag (INTL) is set when the right port writes to memory location 3FFE (HEX). The left port clears the interrupt by reading address location 3FFE. Likewise, the right port interrupt flag (INTR) is set when the left port writes to memory location 3FFF (HEX) and to clear the interrupt flag (INTR), the right port must read the memory location 3FFF. The message (8 bits) at 3FFE or 3FFF is user-defined. If the interrupt function is not used, address locations 3FFE and 3FFF are not used as mail boxes, but as part of the random access memory. Refer to Table 1 for the interrupt operation.

BUSY LOGIC

Busy Logic provides a hardware indication that both ports of the RAM have accessed the same location at the same time. It also allows one of the two accesses to proceed and signals the other side that the RAM is "busy". The busy pin can then be used to stall the access until the operation on the other side is completed. If a write operation has been attempted from the side that receives a busy indication, the write signal is gated internally to prevent the write from proceeding.

The use of busy logic is not required or desirable for all applications. In some cases it may be useful to logically OR the busy outputs together and use any busy indication as an interrupt source to flag the event of an illegal or illogical

operation. If the write inhibit function of busy logic is not desirable, the busy logic can be disabled by placing the part in slave mode with the $\overline{M/\overline{S}}$ pin. Once in slave mode the BUSY pin operates solely as a write inhibit input pin. Normal operation can be programmed by tying the BUSY pins high. If desired, unintended write operations can be prevented to a port by tying the busy pin for that port low.

The busy outputs on the IDT 7006 RAM in master mode, are push-pull type outputs and do not require pull up resistors to operate. If these RAMs are being expanded in depth, then the busy indication for the resulting array requires the use of an external AND gate.

WIDTH EXPANSION WITH BUSY LOGIC MASTER/SLAVE ARRAYS

When expanding an IDT7006 RAM array in width while using busy logic, one master part is used to decide which side of the RAMs array will receive a busy indication, and to output that indication. Any number of slaves to be addressed in the same address range as the master, use the busy signal as a write inhibit signal. Thus on the IDT7006 RAM the busy pin is an output if the part is used as a master ($\overline{M/\overline{S}}$ pin = H), and the busy pin is an input if the part used as a slave ($\overline{M/\overline{S}}$ pin = L).

If two or more master parts were used when expanding in width, a split decision could result with one master indicating busy on one side of the array and another master indicating busy on one other side of the array. This would inhibit the write operations from one port for part of a word and inhibit the write operations from the other port for the other part of the word.

The busy arbitration, on a master, is based on the chip enable and address signals only. It ignores whether an access is a read or write. In a master/slave array, both address and chip enable must be valid long enough for a busy flag to be output from the master before the actual write pulse can be initiated with the $\overline{R/\overline{W}}$ signal. Failure to observe this timing can result in a glitched internal write inhibit signal and corrupted data in the slave.

SEMAPHORES

The IDT7006 is an extremely fast dual-port 16K x 8 CMOS static RAM with an additional 8 address locations dedicated to binary semaphore flags. These flags allow either processor on the left or right side of the dual-port RAM to claim a privilege over the other processor for functions defined by the system designer's software. As an example, the semaphore can be used by one processor to inhibit the other from accessing a portion of the dual-port RAM or any other shared resource.

The dual-port RAM features a fast access time, and both ports are completely independent of each other. This means that the activity on the left port in no way slows the access time of the right port. Both ports are identical in function to standard CMOS static RAM and can be read from, or written to, at the same time with the only possible conflict arising from the simultaneous writing of, or a simultaneous READ/WRITE of, a non-semaphore location. Semaphores are protected against such ambiguous situations and may be used by the system program to avoid any conflicts in the non-semaphore portion of the dual-port RAM. These devices have an automatic power-down feature controlled by \overline{CE} , the dual-port RAM enable, and \overline{SEM} , the semaphore enable. The \overline{CE} and \overline{SEM} pins control on-chip power down circuitry that permits the respective port to go into standby mode when not selected. This is the condition which is shown in Truth Table where \overline{CE} and \overline{SEM} are both high.

Systems which can best use the IDT7006 contain multiple processors or controllers and are typically very high-speed systems which are software controlled or software intensive. These systems can benefit from a performance increase offered by the IDT7006s hardware semaphores, which provide a lockout mechanism without requiring complex programming.

Software handshaking between processors offers the maximum in system flexibility by permitting shared resources to be allocated in varying configurations. The IDT7006 does not use its semaphore flags to control any resources through hardware, thus allowing the system designer total flexibility in system architecture.

An advantage of using semaphores rather than the more common methods of hardware arbitration is that wait states are never incurred in either processor. This can prove to be a major advantage in very high-speed systems.

HOW THE SEMAPHORE FLAGS WORK

The semaphore logic is a set of eight latches which are independent of the dual-port RAM. These latches can be used to pass a flag, or token, from one port to the other to indicate that a shared resource is in use. The semaphores provide a hardware assist for a use assignment method called "Token Passing Allocation." In this method, the state of a semaphore latch is used as a token indicating that shared resource is in use. If the left processor wants to use this resource, it requests the token by setting the latch. This processor then verifies its success in setting the latch by reading it. If it was successful, it proceeds to assume control over the shared resource. If it was not successful in setting the latch, it determines that the

right side processor has set the latch first, has the token and is using the shared resource. The left processor can then either repeatedly request that semaphore's status or remove its request for that semaphore to perform another task and occasionally attempt again to gain control of the token via the set and test sequence. Once the right side has relinquished the token, the left side should succeed in gaining control.

The semaphore flags are active low. A token is requested by writing a zero into a semaphore latch and is released when the same side writes a one to that latch.

The eight semaphore flags reside within the IDT7006 in a separate memory space from the dual-port RAM. This address space is accessed by placing a low input on the \overline{SEM} pin (which acts as a chip select for the semaphore flags) and using the other control pins (Address, \overline{OE} , and R/W) as they would be used in accessing a standard static RAM. Each of the flags has a unique address which can be accessed by either side through address pins A0–A2. When accessing the semaphores, none of the other address pins has any effect.

When writing to a semaphore, only data pin D₀ is used. If a low level is written into an unused semaphore location, that flag will be set to a zero on that side and a one on the other side (see Table III). That semaphore can now only be modified by the side showing the zero. When a one is written into the same location from the same side, the flag will be set to a one for both sides (unless a semaphore request from the other side is pending) and then can be written to by both sides. The fact that the side which is able to write a zero into a semaphore subsequently locks out writes from the other side is what makes semaphore flags useful in interprocessor communications. (A thorough discussion on the use of this feature follows shortly.) A zero written into the same location from the other side will be stored in the semaphore request latch for that side until the semaphore is freed by the first side.

When a semaphore flag is read, its value is spread into all data bits so that a flag that is a one reads as a one in all data bits and a flag containing a zero reads as all zeros. The read value is latched into one side's output register when that side's semaphore select (\overline{SEM}) and output enable (\overline{OE}) signals go active. This serves to disallow the semaphore from changing state in the middle of a read cycle due to a write cycle from the other side. Because of this latch, a repeated read of a semaphore in a test loop must cause either signal (\overline{SEM} or \overline{OE}) to go inactive or the output will never change.

A sequence WRITE/READ must be used by the semaphore in order to guarantee that no system level contention will occur. A processor requests access to shared resources by attempting to write a zero into a semaphore location. If the semaphore is already in use, the semaphore request latch will contain a zero, yet the semaphore flag will appear as one, a fact which the processor will verify by the subsequent read (see Table III). As an example, assume a processor writes a zero to the left port at a free semaphore location. On a subsequent read, the processor will verify that it has written successfully to that location and will assume control over the resource in question. Meanwhile, if a processor on the right side attempts to write a zero to the same semaphore flag it will fail, as will be verified by the fact that a one will be read from

that semaphore on the right side during subsequent read. Had a sequence of READ/WRITE been used instead, system contention problems could have occurred during the gap between the read and write cycles.

It is important to note that a failed semaphore request must be followed by either repeated reads or by writing a one into the same location. The reason for this is easily understood by looking at the simple logic diagram of the semaphore flag in Figure 4. Two semaphore request latches feed into a semaphore flag. Whichever latch is first to present a zero to the semaphore flag will force its side of the semaphore flag low and the other side high. This condition will continue until a one is written to the same semaphore request latch. Should the other side's semaphore request latch have been written to a zero in the meantime, the semaphore flag will flip over to the other side as soon as a one is written into the first side's request latch. The second side's flag will now stay low until its semaphore request latch is written to a one. From this it is easy to understand that, if a semaphore is requested and the processor which requested it no longer needs the resource, the entire system can hang up until a one is written into that semaphore request latch.

The critical case of semaphore timing is when both sides request a single token by attempting to write a zero into it at the same time. The semaphore logic is specially designed to resolve this problem. If simultaneous requests are made, the logic guarantees that only one side receives the token. If one side is earlier than the other in making the request, the first side to make the request will receive the token. If both requests arrive at the same time, the assignment will be arbitrarily made to one port or the other.

One caution that should be noted when using semaphores is that semaphores alone do not guarantee that access to a resource is secure. As with any powerful programming technique, if semaphores are misused or misinterpreted, a software error can easily happen.

Initialization of the semaphores is not automatic and must be handled via the initialization program at power-up. Since any semaphore request flag which contains a zero must be reset to a one, all semaphores on both sides should have a one written into them at initialization from both sides to assure that they will be free when needed.

USING SEMAPHORES—SOME EXAMPLES

Perhaps the simplest application of semaphores is their application as resource markers for the IDT7006's dual-port RAM. Say the 16K x 8 RAM was to be divided into two 8K x 8 blocks which were to be dedicated at any one time to servicing either the left or right port. Semaphore 0 could be used to indicate the side which would control the lower section of memory, and Semaphore 1 could be defined as the indicator for the upper section of memory.

To take a resource, in this example the lower 8K of dual-port RAM, the processor on the left port could write and

then read a zero in to Semaphore 0. If this task were successfully completed (a zero was read back rather than a one), the left processor would assume control of the lower 8K. Meanwhile the right processor was attempting to gain control of the resource after the left processor, it would read back a one in response to the zero it had attempted to write into Semaphore 0. At this point, the software could choose to try and gain control of the second 8K section by writing, then reading a zero into Semaphore 1. If it succeeded in gaining control, it would lock out the left side.

Once the left side was finished with its task, it would write a one to Semaphore 0 and may then try to gain access to Semaphore 1. If Semaphore 1 was still occupied by the right side, the left side could undo its semaphore request and perform other tasks until it was able to write, then read a zero into Semaphore 1. If the right processor performs a similar task with Semaphore 0, this protocol would allow the two processors to swap 8K blocks of dual-port RAM with each other.

The blocks do not have to be any particular size and can even be variable, depending upon the complexity of the software using the semaphore flags. All eight semaphores could be used to divide the dual-port RAM or other shared resources into eight parts. Semaphores can even be assigned different meanings on different sides rather than being given a common meaning on different sides rather than being given a common meaning as was shown in the example above.

Semaphores are a useful form of arbitration in systems like disk interfaces where the CPU must be locked out of a section of memory during a transfer and the I/O device cannot tolerate any wait states. With the use of semaphores, once the two devices has determined which memory area was "off-limits" to the CPU, both the CPU and the I/O devices could access their assigned portions of memory continuously without any wait states.

Semaphores are also useful in applications where no memory "WAIT" state is available on one or both sides. Once a semaphore handshake has been performed, both processors can access their assigned RAM segments at full speed.

Another application is in the area of complex data structures. In this case, block arbitration is very important. For this application one processor may be responsible for building and updating a data structure. The other processor then reads and interprets that data structure. If the interpreting processor reads an incomplete data structure, a major error condition may exist. Therefore, some sort of arbitration must be used between the two different processors. The building processor arbitrates for the block, locks it and then is able to go in and update the data structure. When the update is completed, the data structure block is released. This allows the interpreting processor to come back and read the complete data structure, thereby guaranteeing a consistent data structure.

IDT7006S/L
HIGH-SPEED 16K x 8 DUAL-PORT STATIC RAM

MILITARY AND COMMERCIAL TEMPERATURE RANGES

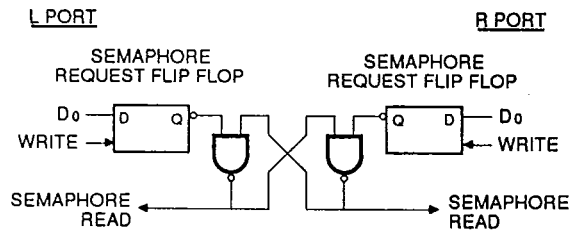

Figure 4. IDT7006 Semaphore Logic

ORDERING INFORMATION

IDT	XXXXX	A	999	A	A	
Device Type	Power	Speed	Package	Process/ Temperature Range		
					Blank	Commercial (0°C to +70°C)
					B	Military (-55°C to +125°C) Compliant to MIL-STD-883, Class B
					G	68-pin PGA
					J	68-pin PLCC
					F	68-pin Flatpack
					L68	68-pin LCC
					35	Commercial Only } Speed in Nanoseconds
					45	
					55	
					70	
					S	Standard Power
					L	Low Power
					7006	128K (16K x 8) Dual-Port RAM

2739 drw 22

