



3.3 Volt CMOS 8-Bit Buffers/Line Drivers

QS74FCT3240
QS74FCT3244
QS74FCT32240
QS74FCT32244

FEATURES/BENEFITS

- Pin and function compatible to the 74F240/4 74LVT240/4 and 74FCT240T/4T
- Available in SOIC and QSOP
- Undershoot clamp diodes on all inputs
- Ground bounce controlled outputs
- Low power QCMOS: 0.03 μ W typ static
- JEDEC spec compatible
- $I_{OL} = 24$ mA Com.
- TTL-compatible input and output levels
- Extended temperature -40°C to $+85^{\circ}\text{C}$
- 2.7V to 3.6V Supply Voltage
- 5V compatible input pins

2

DESCRIPTION

The FCT3240 and FCT3244 are 8-bit buffers/line drivers with three-state outputs that is ideal for driving high-capacitance loads as in memory address and data buses. All inputs have clamp diodes for undershoot noise suppression and all outputs have ground bounce suppression (see QSI Application Note AN-01). Input pins can be driven by 3.3V or 5V components allowing voltage transition in mixed supply systems. Ultra-low power QCMOS technology makes this product ideal for portable computing systems or communications devices.

FUNCTIONAL BLOCK DIAGRAM

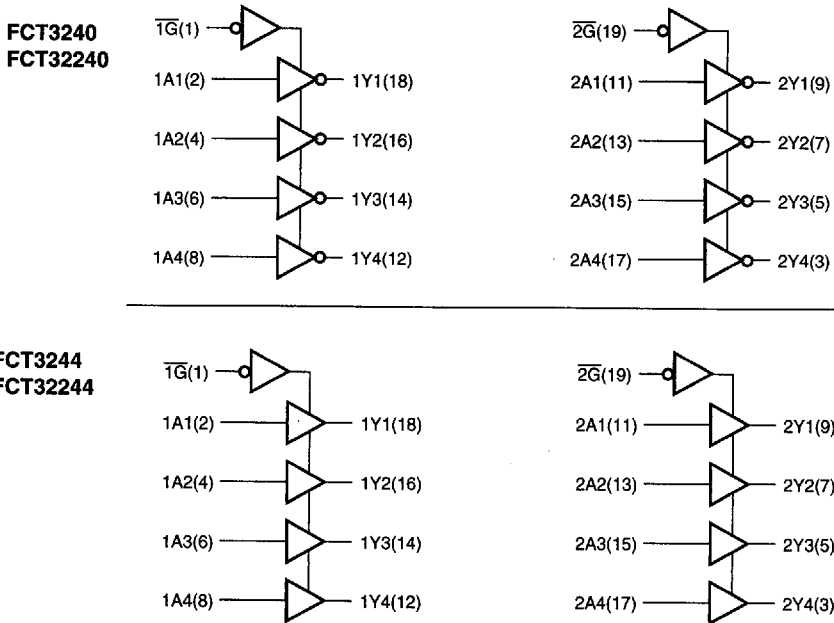

PIN CONFIGURATION

(All Pins Top View)

Note: For QVSOP, see QS74FCT2X3244 Datasheet (MDSL-00063)

SOIC, QSOP

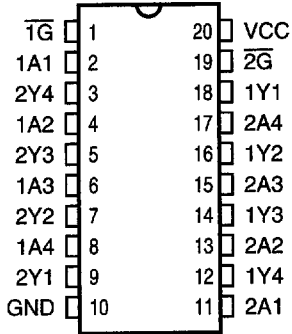

PIN DESCRIPTION

Name	I/O	Description
xA4-xA0	I	Data Inputs
xY4-xY0	O	Data Outputs - Three State
$\overline{1G}$	I	Output Enable
$\overline{2G}$	I	Output Enable

FCT3240/32240 FUNCTION TABLE

$\overline{1G}, \overline{2G}$	Input A	Output Y
H	X	Z
L	L	H
L	H	L

FCT3244/32244 FUNCTION TABLE

$\overline{1G}, \overline{2G}$	Input A	Output Y
H	X	Z
L	L	L
L	H	H

ABSOLUTE MAXIMUM RATINGS⁽¹⁾

Supply Voltage to Ground	-0.5V to +4.6V
DC Output Voltage V_{OUT}	-0.5V to $V_{CC} + 0.5V^{(2)}$
DC Input Voltage V_{IN}	-0.5V to +7.0V
AC Input Voltage (for a pulse width ≤ 20 ns)	-3.0V
DC Input Diode Current with $V_{IN} < 0$	± 20 mA
DC Output Diode Current with $V_{OUT} < 0$	± 50 mA
DC Output Current Max. Sink Current/Pin	± 60 mA
Maximum Power Dissipation	0.9 watts
T_{STG} Storage Temperature	-65° to +150°C

Note:

1. Stresses greater than those listed under ABSOLUTE MAXIMUM RATINGS may cause permanent damage to this device resulting in functional or reliability type failures.
2. Not to exceed 4.6V

2

CAPACITANCE

$T_A = 25^\circ\text{C}$, $f = 1$ MHz, $V_{IN} = 0V$, $V_{OUT} = 0V$

Pins	SOIC	QSOP	Unit
1, 19	4	4	pF
2-9, 11-18	8	8	pF

Note: Capacitance is characterized but not tested.

RECOMMENDED OPERATING CONDITIONS

Symbol	Description	Min	Max	Unit
V_{CC}	Supply Voltage	2.7	3.6	V
V_{IN}	Input Voltage	0	V_{CC}	V
V_{OUT}	Output Voltage	0	V_{CC}	V
T_A	Ambient Operating Temperature	-40	+85	°C
$\Delta t/\Delta V$	Input Transition Rise or Fall Rate ⁽¹⁾	0	8	ns/V

Notes:

1. As measured between 0.8V and 2V.

QSFCT3240, 3244, 32240, 32244 PRELIMINARY

DC ELECTRICAL CHARACTERISTICS OVER OPERATING RANGE

Recommended operating conditions apply unless otherwise specified.

Symbol	Parameter	Test Conditions	Min	Typ ⁽¹⁾	Max	Unit
V _{IH}	Input HIGH Voltage	Input Pins	2.0	—	5.5	V
		I/O Pins	2.0	—	V _{CC} +0.5	V
V _{IL}	Input LOW Voltage	Input Pins	-0.5	—	0.8	V
ΔV _T	Input Hysteresis	V _{T_{LH}} - V _{T_{HL}} for All Inputs	—	0.2	—	V
I _{I_{IH}} I _{I_{IL}}	Input Current Input HIGH or LOW	V _{CC} = Max., 0 ≤ V _{IN} < V _{CC}	—	—	1	μA
I _{OZ}	Off-State Output Current (Hi-Z)	V _{CC} = Max., 0 ≤ V _{IN} ≤ V _{CC}	—	—	5	μA
I _{OS}	Short Circuit Current	V _{CC} = Max., V _{OUT} = GND ^(2,3)	-60	—	-225	mA
V _{IC}	Input Clamp Voltage	V _{CC} = Min., I _{IN} = -18 mA ⁽³⁾	—	-0.7	—	V
V _{OH}	Output HIGH Voltage	V _I = V _{IH} or V _{IL} , V _{CC} = Min, I _{OH} = -100 μA	V _{CC} -0.2	—	—	V
		V _I = V _{IH} or V _{IL} , V _{CC} = 3V, I _{OH} = -8 mA	2.4	—	—	V
V _{OL}	Output LOW Voltage (FCT324X)	V _I = V _{IH} or V _{IL} , V _{CC} = Min, I _{OL} = 100 μA	—	—	0.2	V
		V _I = V _{IH} or V _{IL} , V _{CC} = 3V, I _{OL} = 16 mA	—	—	0.4	V
		V _I = V _{IH} or V _{IL} , V _{CC} = 3V, I _{OL} = 24 mA	—	—	0.5	V
V _{OL}	Output LOW Voltage (FCT3224X-25Ω)	V _I = V _{IH} or V _{IL} , V _{CC} = 3V, I _{OL} = 8 mA	—	—	0.5	V
R _{OUT}	Output Resistance ⁽⁴⁾ (FCT3224X-25Ω)	V _{CC} = 3V, I _{OL} = 8 mA	—	40	—	Ω

Notes:

1. Typical values indicate V_{CC} = 3.3V and T_A = 25°C.
2. Not more than one output should be shorted and the duration is ≤1 second.
3. These parameters are guaranteed by design but not tested.
4. R_{OUT} represents total output impedance and includes added series termination resistance.

POWER SUPPLY CHARACTERISTICS

Symbol	Parameter	Test Conditions ⁽¹⁾	Min	Typ	Max	Unit
I _{cc}	Quiescent Power Supply Current	V _{cc} = Max., freq = 0 0V ≤ V _{IN} ≤ 0.2V or V _{cc} -0.2V ≤ V _{IN} ≤ V _{cc}	—	0.01	20	μA
ΔI _{cc}	Supply Current per Input @ TTL HIGH	V _{cc} = Max., freq = 0, V _{IN} = V _{cc} - 0.6V	—	1.0	20	μA
Q _{CCD}	Supply Current per Input per MHz	V _{cc} = Max., Outputs Open and Enabled One Bit Toggling @ 50% Duty Cycle Other Inputs at GND or V _{cc} ^(2,3)	—	40	85	μA/ MHz

2

Notes:

1. For conditions shown as Min. or Max., use the appropriate values specified under DC specifications.
2. For flip-flops, Q_{CCD} is measured by switching one of the data input pins so that the output changes every clock cycle. This is a measurement of device power consumption only and does not include power to drive load capacitance or tester capacitance. This parameter is guaranteed by design but not tested.
3. I_c can be computed using the above parameters as explained in the Technical Overview section.

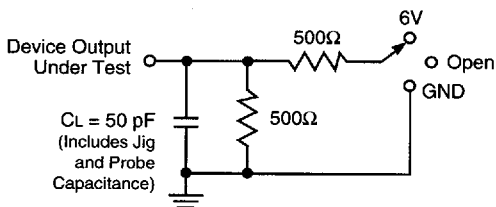

Test	Switch
t _{PHL} /t _{PLH}	Open
t _{PZL} /t _{PLZ}	6V
t _{PZH} /t _{PHZ}	GND

Load Circuit for Outputs

Notes

1. Input pulse characteristics: 0V to 2.7V, t_r = t_f = 2.5 ns (10% to 90%), transition measured at 1.5V, pulse generator Z_{OUT} = 50Ω.

QSFCT3240, 3244, 32240, 32244 PRELIMINARY

SWITCHING CHARACTERISTICS OVER OPERATING RANGE

Recommended operating conditions apply unless otherwise specified.

FCT3240/32240

Symbol	Description ⁽¹⁾	3240, 32240 (V _{CC} = 3.3V ± 0.3V)		3240A, 32240A (V _{CC} = 3.3V ± 0.3V)		Unit
		Min	Max	Min	Max	
t _{PLH} t _{PHL}	Propagation Delay Ai to Yi, FCT3240	1.5	8	1.5	4.8	ns
t _{PLH} t _{PHL}	Propagation Delay Ai to Yi, FCT32240	1.5	8	1.5	4.8	ns
t _{PZH} t _{PZL}	Output Enable \overline{OE} to Yi, FCT3240	1.5	10	1.5	6.2	ns
t _{PZH} t _{PZL}	Output Enable \overline{OE} to Yi, FCT32240	1.5	10	1.5	6.2	ns
t _{PLZ} t _{PHZ}	Disable Time ⁽²⁾	1.5	9.5	1.5	5.6	ns

Notes:

1. Minimums guaranteed but not tested.
2. This parameter is guaranteed by design but not tested.
3. See Test Circuit and Waveforms.

FCT3244/32244

Symbol	Description ⁽¹⁾	3244, 32244 (V _{CC} = 3.3V ± 0.3V)		3244A, 32244A (V _{CC} = 3.3V ± 0.3V)		Unit
		Min	Max	Min	Max	
t _{PLH} t _{PHL}	Propagation Delay Ai to Yi, FCT3244	1.5	6.5	1.5	4.8	ns
t _{PLH} t _{PHL}	Propagation Delay Ai to Yi, FCT32244	1.5	6.5	1.5	4.8	ns
t _{PZH} t _{PZL}	Output Enable \overline{OE} to Yi, FCT3244	1.5	8	1.5	6.2	ns
t _{PZH} t _{PZL}	Output Enable \overline{OE} to Yi, FCT32244	1.5	8	1.5	6.2	ns
t _{PLZ} t _{PHZ}	Disable Time ⁽²⁾	1.5	7	1.5	5.6	ns

Notes:

1. Minimums guaranteed but not tested.
2. This parameter is guaranteed by design but not tested.
3. See Test Circuit and Waveforms.

Q

Packaging Information

QSI uses a one or two character package code in the part numbers of its products to indicate the package. The package code is uniform over all part numbers unless otherwise noted. The following is a table of these package codes and their corresponding package. The package outline drawing for each of these packages is shown on the following pages.

QSI Package Codes

Pkg Code	Package Type	Comments	Page
H	Ceramic QSOP, 150 mil Gull Wing	25 mil pitch	5-3
Q	QSOP, 150 mil Gull Wing	25 mil pitch	5-4
Q2	QVSOP, 150 mil Gull Wing, 40-pin	0.5 mm (19.6 mil) pitch	5-5
SO	SOIC, 300 mil Gull Wing	5-6

150 MIL HQSOP - Package Code H

Hermetic Quarter Size Outline Package
Ceramic Small Outline Gull Wing

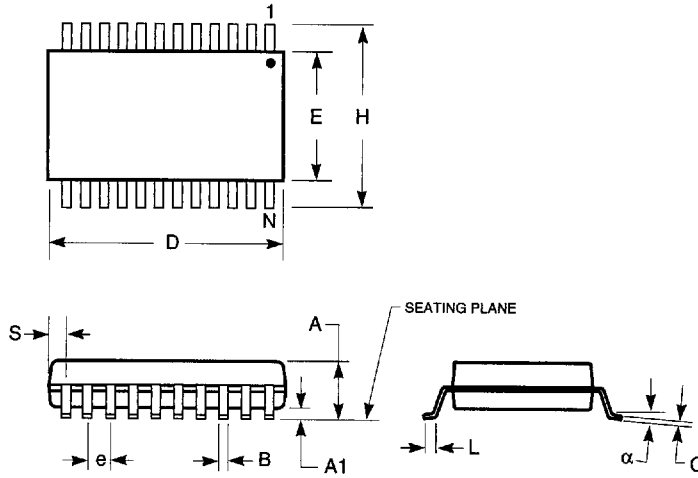

Notes:

1. Refer to applicable symbol list.
2. All dimensions are in inches.
3. N is the number of lead positions.
4. Dimensions D and E are to be measured at maximum material condition.
5. Lead coplanarity is 0.004 in. maximum.

JEDEC#	TBD			TBD		
	HSS-20A			HSS-24A		
DWG#	Min	Nom	Max	Min	Nom	Max
A	0.070	0.074	0.078	0.070	0.074	0.078
A1	0.008	0.012	0.016	0.008	0.012	0.016
B	0.009	0.010	0.012	0.009	0.010	0.012
C	0.007	0.008	0.010	0.007	0.008	0.010
D	0.337	0.342	0.350	0.337	0.342	0.350
E	0.150	0.155	0.158	0.150	0.155	0.158
e	0.025 BSC			0.025 BSC		
H	0.230	0.236	0.244	0.230	0.236	0.244
L	0.016	0.025	0.035	0.016	0.025	0.035
N	20			24		
α	0°	5°	8°	0°	5°	8°
S	0.056	0.058	0.062	0.031	0.033	0.037

5

PACKAGING INFORMATION

150 MIL QSOP - Package Code Q

Quarter Size Outline Package
Plastic Small Outline Gull Wing

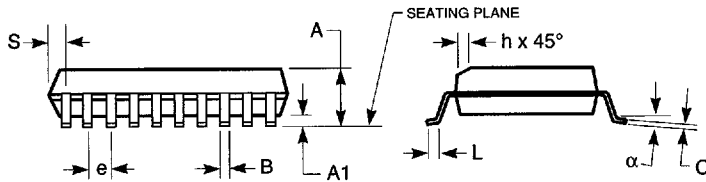
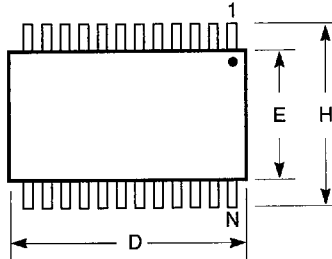

Notes:

1. Refer to applicable symbol list.
2. All dimensions are in inches.
3. N is the number of lead positions.
4. Dimensions D and E are to be measured at maximum material condition but do not include mold flash. Allowable mold flash is 0.006 in per side.
5. Lead coplanarity is 0.004 in maximum.

JEDEC#	MO-137AB			MO-137AD			MO-137AE			MO-137AF		
DWG#	PSS-16A			PSS-20A			PSS-24A			PSS-28A		
Symbol	Min	Nom	Max	Min	Nom	Max	Min	Nom	Max	Min	Nom	Max
A	0.060	0.064	0.068	0.060	0.064	0.068	0.060	0.064	0.068	0.060	0.064	0.068
A1	0.004	0.006	0.008	0.004	0.006	0.008	0.004	0.006	0.008	0.004	0.006	0.008
B	0.009	0.010	0.012	0.009	0.010	0.012	0.009	0.010	0.012	0.009	0.010	0.012
C	0.007	0.008	0.010	0.007	0.008	0.010	0.007	0.008	0.010	0.007	0.008	0.010
D	0.189	0.193	0.197	0.337	0.341	0.344	0.337	0.341	0.344	0.386	0.390	0.394
E	0.150	0.154	0.157	0.150	0.154	0.157	0.150	0.154	0.157	0.150	0.154	0.157
e	0.025 BSC			0.025 BSC			0.025 BSC			0.025 BSC		
H	0.230	0.236	0.244	0.230	0.236	0.244	0.230	0.236	0.244	0.230	0.236	0.244
h	0.010	0.013	0.016	0.010	0.013	0.016	0.010	0.013	0.016	0.010	0.013	0.016
L	0.016	0.025	0.035	0.016	0.025	0.035	0.016	0.025	0.035	0.016	0.025	0.035
N	16			20			24			28		
alpha	0°	5°	8°	0°	5°	8°	0°	5°	8°	0°	5°	8°
S	0.006	0.009	0.010	0.056	0.058	0.060	0.031	0.033	0.035	0.031	0.033	0.035

3.3 VOLT FCT PRODUCT BROCHURE

150 MIL QVSOP™ - Package Code Q1/Q2
150 Mil Wide Plastic Small Outline Gull Wing

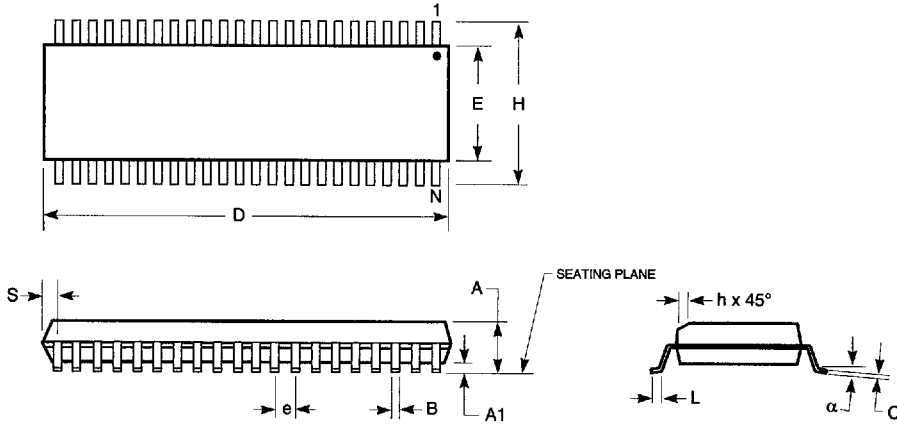

5

JEDEC#	MO-154BB			MO-154AB		
DWG#	PSS-40A			PSS-48A		
Symbol	Min	Nom	Max	Min	Nom	Max
A	0.059	0.065	0.069	0.059	0.065	0.069
A1	0.004	0.006	0.008	0.004	0.006	0.008
B	0.0067	0.008	0.009	0.0051	0.0063	0.008
C	0.0075	0.008	0.0098	0.0075	0.008	0.0098
D	0.386	0.390	0.394	0.386	0.390	0.394
E	0.150	0.154	0.157	0.150	0.154	0.157
e	0.0197 BSC 0.5mm			0.0157 BSC, 0.4mm		
H	0.228	0.236	0.244	0.228	0.236	0.244
h	0.010	0.013	0.016	0.010	0.013	0.016
L	0.020	0.024	0.030	0.020	0.024	0.030
N	40			48		
α	0°	5°	8°	0°	5°	8°
S	0.006	0.008	0.010	0.012	0.014	0.016

Notes:

1. Refer to applicable symbol list.
2. All dimensions are in inches.
3. N is the number of lead positions.
4. Dimensions D and E are to be measured at maximum material condition but do not include mold flash. Allowable mold flash is 0.006 in per side.
5. Lead coplanarity is 0.003 in maximum.

PACKAGING INFORMATION

300 MIL SOIC - Package Code SO Plastic Small Outline Gull Wing

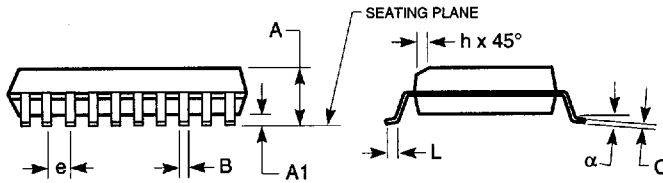
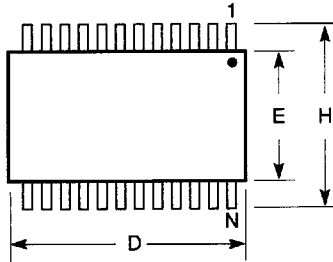

Notes:

1. Refer to applicable symbol list.
2. All dimensions are in inches.
3. N is the number of lead positions.
4. Dimensions D and E are to be measured at maximum material condition but do not include mold flash. Allowable mold flash is 0.006 in. per side.
5. Lead coplanarity is 0.004 in maximum.

JEDEC#	MS-013AA		MS-013AC		MS-013AD		MS-013AE	
DWG#	PS16A		PS20A		PS24A		PS28A	
Symbol	Min	Max	Min	Max	Min	Max	Min	Max
A	.096	.104	.096	.104	.096	.104	.096	.104
A1	.005	.011	.005	.011	.005	.011	.005	.011
B	.014	.019	.014	.019	.014	.019	.014	.019
C	.009	.012	.009	.012	.009	.012	.009	.012
D	.402	.412	.500	.510	.602	.612	.701	.711
E	.292	.299	.292	.299	.292	.299	.292	.299
e	.044	.056	.044	.056	.044	.056	.044	.056
H	.396	.416	.396	.416	.396	.416	.396	.416
h	.010	.016	.010	.016	.010	.016	.010	.016
L	.020	.040	.020	.040	.020	.040	.020	.040
N	16		20		24		28	
α	0°	8°	0°	8°	0°	8°	0°	8°