

POWER MANAGEMENT

Single Cell Battery Powered Electroluminescent Lamp Driver/Inverter

The IMP527 is an Electroluminescent (EL) lamp driver designed for systems that must operate down to 1 volt and below. The input supply voltage range is 0.9V to 2.5V. Typical output lamp drive voltage is 180V. All four EL lamp-driving functions are on-chip. These are the switch-mode power supply, its high-frequency oscillator, the high-voltage H-bridge lamp driver and its low-frequency oscillator. EL lamps of up to 6nF capacitance can be driven to high brightness.

The circuit requires few external components; one inductor, one diode, one capacitor and two resistors. The resistors set the frequency for the two oscillators.

A disable mode puts the chip into a low current-drain state. When disabled, quiescent current drops to 1 μ A typical with a V_{DD} of 1.5V. The chip can be disabled by connecting R_{SW} , the oscillator frequency setting resistor, to ground. A disable pad (active low), accessible only on the die, can also be used to disable the driver.

An internal circuit shuts down the switching regulator when the lamp drive voltage exceeds 180V peak-to-peak. This conserves power and extends battery life.

The IMP527 is available in MicroSO and SO-8 packages and in die form.

Key Features

- ◆ Wide operating voltage range - from 0.9V to 2.5V
- ◆ Simple design requires few passive components
- ◆ 180V peak-to-peak typical AC output voltage
- ◆ Adjustable output frequency controls lamp color and power consumption
- ◆ Adjustable converter frequency minimizes circuit power consumption
- ◆ Disable mode extends battery life
- ◆ Disable current 1 μ A typical
- ◆ Compact MicroSO package option

Applications

- ◆ Audio/TV remote control units
- ◆ Pagers/Cellular phones
- ◆ PDAs
- ◆ Clocks and radios
- ◆ Portable GPS receivers
- ◆ LCD modules
- ◆ Toys

Block Diagram

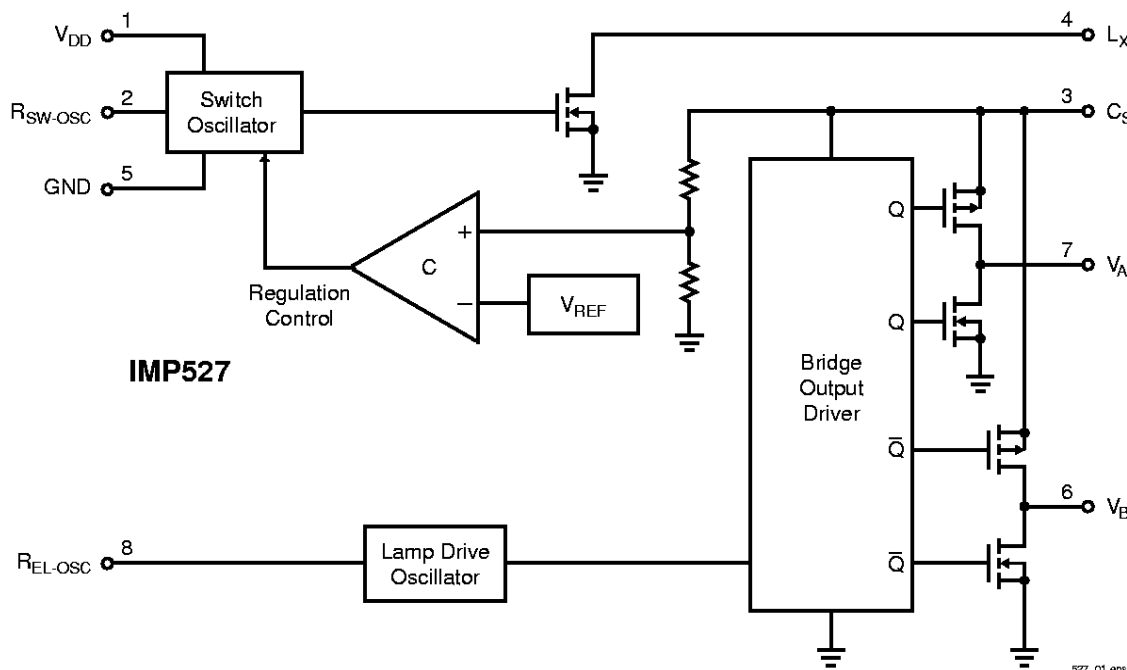

Pin Configuration

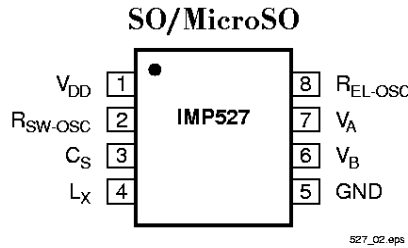

Ordering Information

Part Number	Input Voltage	Regulated Output Voltage	Temperature Range	Pins-Package
IMP527EMA	0.9V to 2.5V	YES	-40°C to +85°C	8-MicroSO
IMP527ESA	0.9V to 2.5V	YES	-40°C to +85°C	8-SO
IMP527/D	0.9V to 2.5V	YES	25°C	Dice

Absolute Maximum Ratings

Supply Voltage, V_{DD} , $V_{RSW-OSC}$ and $V_{REL-OSC}$. . . -0.5V to +3.5V
 Storage Temperature Range -65°C to +150°C
 Power Dissipation (SO package) 400mW
 Power Dissipation (MicroSO package) 300mW

Note: All voltages are referenced to GND.

These are stress ratings only and functional operation is not implied. Exposure to absolute maximum ratings for prolonged time periods may affect device reliability.

Electrical Characteristics

Unless otherwise noted, $V_{DD} = 1.5V$, $R_{SW} = 1M\Omega$, $R_{EL} = 1M\Omega$, and $T_A = 25^\circ C$.

Parameter	Symbol	Conditions	Min	Typ	Max	Units
ON-resistance of MOS Switch	$R_{DS(ON)}$	$I = 50mA$			15	Ω
Operating Voltage			0.9		2.5	V
Output Voltage at C_S	V_{CS}	$V_{DD} = 1.5V$, See Figure 1, Table 1	80	90		V
Output Voltage at C_S	V_{CS}	$V_{DD} = 0.9V$, See Figure 1, Table 2		50		V
Output Voltage Peak-to-Peak	V_A-V_B	$V_{DD} = 1.5V$, See Figure 1		180		V_{P-P}
Quiescent V_{DD} Supply Current, Disabled (Disable pin available on die only)	I_{DIS}	Disable = HIGH		70		nA
Quiescent V_{DD} Supply Current, Disabled	I_{DIS}	$R_{SW-OSC} = GND$ $V_{DD} = 1.5V$		1.0	2.0	μA
Input Current at V_{DD} Pin	I_{DD}	$V_{DD} = 0.9V$ to $1.5V$			1.5	mA
Input Current: I_{DD} Plus Inductor Current	I_{IN}	$V_{DD} = 1.5V$, See Figure 1, Table 1		26	32	mA
V_{A-B} Output Drive Frequency	f_{EL}	$V_{DD} = 1.5V$, See Figure 1, Table 1		500		Hz
Boost Converter Switching Frequency	f_{SW}	$V_{DD} = 1.5V$, See Figure 1, Table 1		26		kHz
Switching Duty Cycle	D_{SW}	$V_{DD} = 1.5V$, See Figure 1		87.5		%
Disable Input LOW Voltage (Disable pin available on die only)	V_{DISL}		GND		0.2	V
Disable Input HIGH Voltage (Disable pin available on die only)	V_{DISH}		$V_{DD} - 0.5V$		V_{DD}	V

Typical Characteristics

EL Lamp Drive Frequency

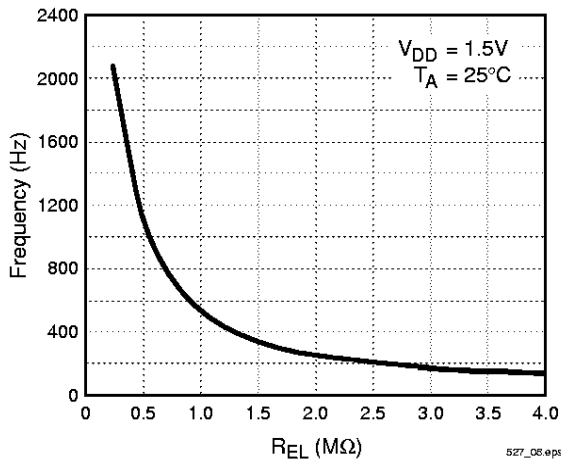

Boost Converter Switching Frequency

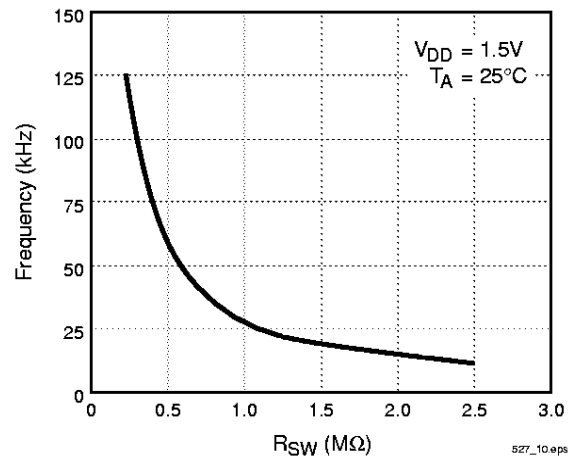

EL Lamp Drive Period

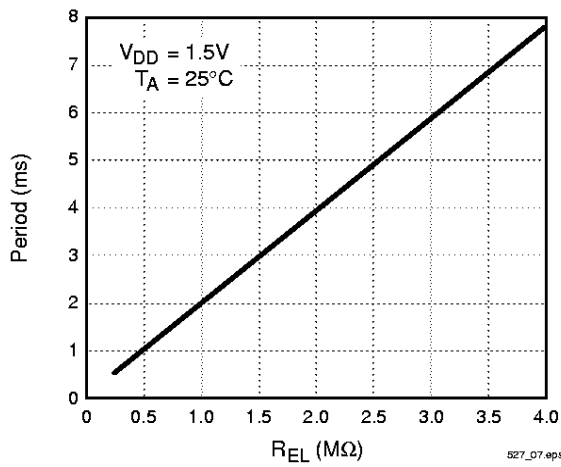

Boost Converter Switching Period

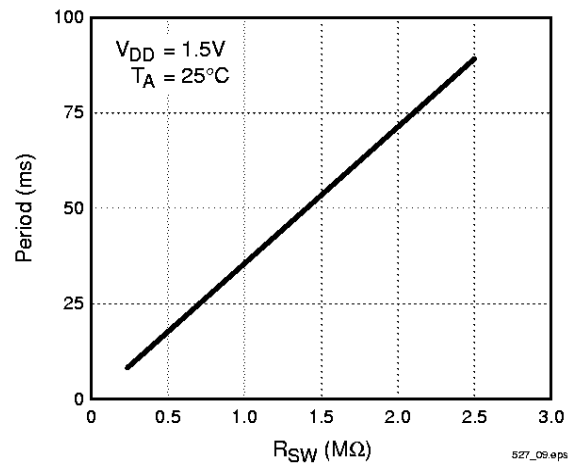

Pin Descriptions

Pin Number	Name	Function
1	V _{DD}	Positive voltage supply for the IMP527. Inductor L may be connected here or to a separate supply.
2	R _{SW-OSC}	Switch-mode resistor pin. Switching frequency is determined by external resistor R _{SW} , connected between pin 2 and V _{DD} .
3	C _S	Boost converter storage capacitor. The voltage across the EL lamp is equal to twice the voltage at C _S .
4	L _X	Connection to flyback inductance, L.
5	GND	Ground pin.
6	V _B	EL lamp drive. The lamp is connected to a high-voltage bridge circuit with V _B providing the complementary connection to V _A .
7	V _A	EL lamp drive. (See above)
8	R _{EL-OSC}	The EL lamp oscillator frequency-setting pin. The frequency is controlled by resistor R _{EL} , connected from pin 8 to V _{DD} .
Disable Pad	DIS	Available only in die form. Setting DIS HIGH disables the chip.

External Components

External Component	Description and Selection Guide
Diode	A fast reverse recovery diode, with BV > 100, such as a 1N4148.
Capacitor C _S	The high voltage capacitor that stores the inductive energy transferred through the catch diode. A 100 volt capacitor between 10nF and 100nF is recommended.
Resistor R _{EL}	The EL lamp oscillator frequency-setting resistor. R _{EL} is connected between pin 8 and V _{DD} , providing a frequency inversely proportional to R _{EL} ; as R _{EL} increases, the EL lamp frequency decreases along with the current drawn by the lamp. Lamp color is also determined by this frequency. A 1MΩ resistor between the R _{EL-OSC} pin and the V _{DD} supply results in a lamp frequency around 500Hz.
Resistor R _{SW}	Switching Oscillator frequency-setting resistor. R _{SW} is connected between the R _{SW-OSC} pin and the V _{DD} supply. The switching frequency is inversely proportional to the resistor value, dropping as the resistance increases.
Capacitor C _{SW}	This is an optional noise-suppression capacitor connected from ground to the R _{SW-OSC} pin. A 100pF capacitor is recommended.
Inductor L	<p>The inductor provides the voltage boost needed by means of inductive "flyback". The internal MOSFET switch alternately opens and closes the ground connection for the inductor at the L_X pin. When the switch opens, the inductor potential will forward-bias the diode and the current will pass through to the storage capacitor C_S, charging it to a high voltage.</p> <p>As the value of the inductor is increased, the switching frequency set by R_{SW} should also be increased to prevent saturation. In general, smaller value inductors that can handle more current are more desirable when larger-area EL lamps must be driven.</p> <p>A small electrolytic capacitor (10μF, 16V), normally present across the inductor supply V_{IN}, will likely eliminate the need for C_{SW}.</p>

Application Information
Test Circuit

Figure 1 shows the IMP527 configured to drive an EL lamp, represented as a 3nF capacitor.

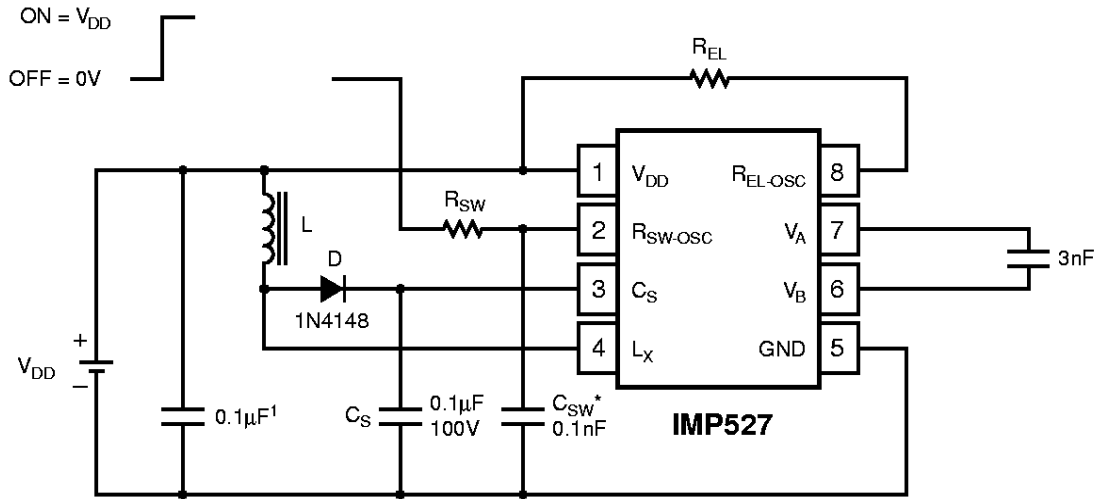

Note:
1. Larger values may be required depending upon supply impedance.

* Optional

527_03.eps

Figure 1. Test Circuit

Table 1. $V_{IN} = 1.5V$

Component	Connections	Value	Description
R_{SW}	V_{DD}, R_{SW-OSC}	1MΩ	Boost converter oscillator bias resistor
R_{EL}	V_{DD}, R_{EL-OSC}	1MΩ	EL lamp driver oscillator bias resistor
L	V_{DD}, L_X^2	330μH ²	Boost converter inductor
C_S	C_S, GND	0.1μF/100V	Boost converter storage capacitor
D	L_X, C_S	1N4148	Switching diode
C_{SW}	R_{SW-OSC}, GND	0.1nF	Noise-suppression capacitor (optional)

Notes. 2. Murata LQH4N331K04 (8.2Ω max. DCR)

Table 2. $V_{IN} = 0.9V$

Component	Connections	Value	Description
R_{SW}	V_{DD}, R_{SW-OSC}	1MΩ	Boost converter oscillator bias resistor
R_{EL}	V_{DD}, R_{EL-OSC}	2.62MΩ	EL lamp driver oscillator bias resistor
L	V_{DD}, L_X^3	680μH ³	Boost converter inductor
C_S	C_S, GND	0.1μF/100V	Boost converter storage capacitor
D	L_X, C_S	1N4148	Switching diode
C_{SW}	R_{SW-OSC}, GND	0.1nF	Noise-suppression capacitor (optional)

Notes. 3. Coilcraft DS1608C-684 (2.2Ω max. DCR)

Enable/Disable Operation

Figure 2 shows how the IMP527 can be enabled via a logic gate that connects R_{SW} to V_{DD} , and disabled by connecting it to ground.

The IMP527 can also be disabled using a pad on the die. The Disable function pin is not available in packaged parts.

Enable/Disable Table	
R_{SW} Connection	IMP527 State
V_{DD}	Enabled
Ground	Disabled

Disable PAD Connection (Available only with dice)	IMP527 State
HIGH (V_{DD})	Disabled
LOW (Ground)	Enabled

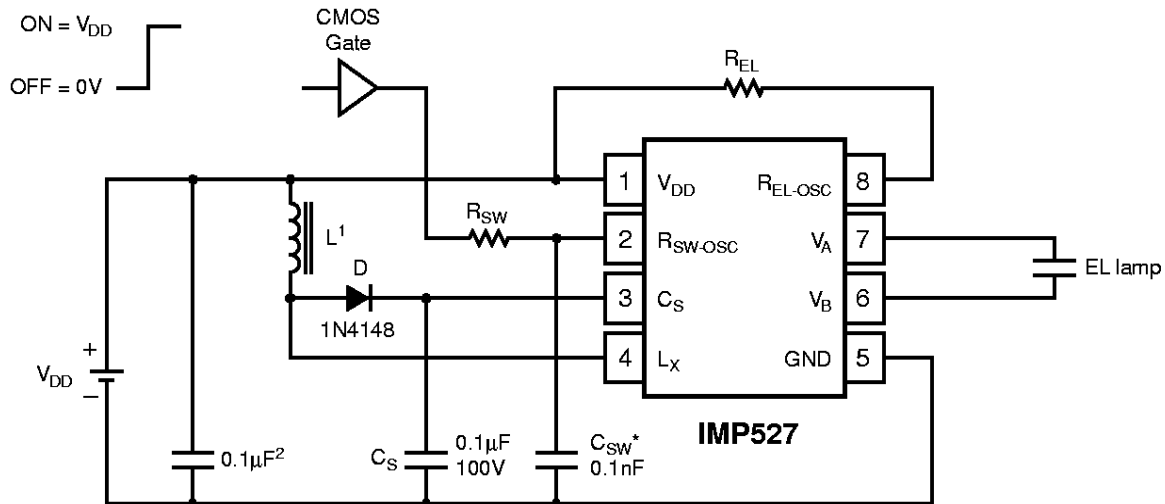

Note:

1. Murata part # LQH4N331K04 (DC resistance < 8.2 Ω)
2. Larger values may be required depending upon supply impedance.

* Optional

527_04.eps

Figure 2. Enable/Disable Operation

High Voltages Present

The IMP527 generates high voltages and caution should be exercised.

Inductor Manufacturers

Manufacturer	Series	USA Phone Number
Toko	D52FU	(847) 297-0070
Coilcraft	DS1608, DO1608, DT1608	(847) 639-6400
River Electronics	FLC32	(310) 320-7488
Murata	LQH4N	(800) 831-9172

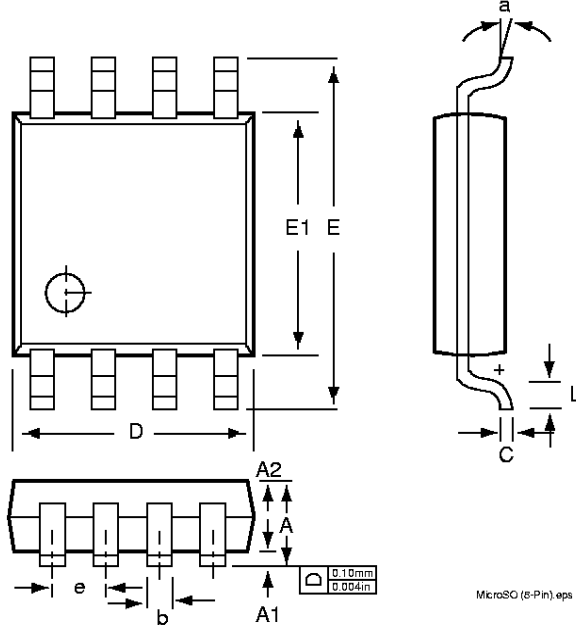
MicroSO (8-Pin)

Package Dimensions

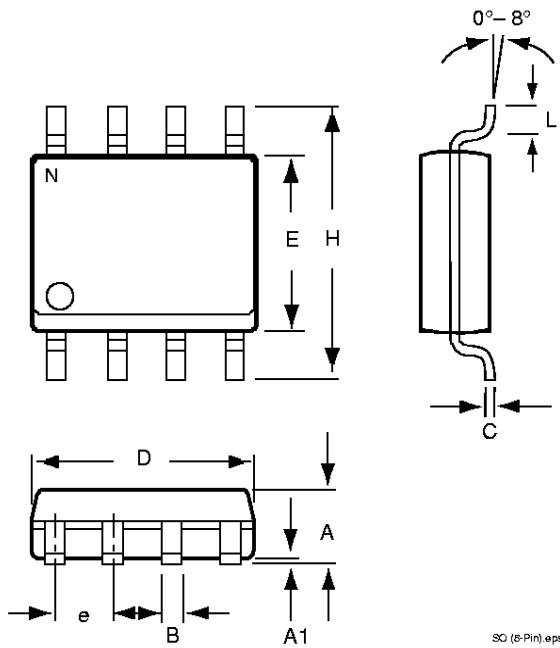
	Inches		Millimeters	
	Min	Max	Min	Max
MicroSO (8-Pin)				
A	—	0.0433	—	1.10
A1	0.0020	0.0059	0.050	0.15
A2	0.0295	0.0374	0.75	0.95
b	0.0098	0.0157	0.25	0.40
C	0.0051	0.0091	0.13	0.23
D	0.1142	0.1220	2.90	3.10
e	0.0256 BSC		0.65 BSC	
E	0.193 BSC		4.90 BSC	
E1	0.1142	0.1220	2.90	3.10
L	0.0157	0.0276	0.40	0.70
a	0°	6°	0°	6°
SO (8-Pin)				
A	0.053	0.069	1.35	1.75
A1	0.004	0.010	0.10	0.25
B	0.013	0.020	0.33	0.51
C	0.007	0.010	0.19	0.25
e	0.050		1.27	
E	0.150	0.157	3.80	4.00
H	0.228	0.244	5.80	6.20
L	0.016	0.050	0.40	1.27
D	0.189	0.197	4.80	5.00

SO (8-Pin)



ISO 9001 Registered

IMP, Inc.
Corporate Headquarters
2830 N. First Street
San Jose, CA 95134-2071
Tel: 408-432-9100
Tel: 800-438-3722
Fax: 408-434-0335
Fax-on-Demand: 1-800-249-1614 (USA)
Fax-on-Demand: 1-303-575-6156 (International)
e-mail: info@impinc.com
<http://www.impweb.com>