

SN54HC109, SN74HC109 DUAL J-K POSITIVE-EDGE-TRIGGERED FLIP-FLOPS WITH CLEAR AND PRESET

D2684, DECEMBER 1982—REVISED JUNE 1989

- Package Options Include Plastic "Small Outline" Packages, Ceramic Chip Carriers, and Standard Plastic and Ceramic 300-mil DIPs
- Dependable Texas Instruments Quality and Reliability

description

These devices contain two independent J-K negative-edge-triggered flip-flops. A low level at the Preset or clear inputs sets or resets the outputs regardless of the levels of the other inputs. When Preset and Clear are inactive (high), data at the J and \bar{K} inputs meeting the setup time requirements are transferred to the outputs on the positive-going edge of the clock pulse. Clock triggering occurs at a voltage level and is not directly related to the rise time of the clock pulse. Following the hold time interval, data at the J and \bar{K} inputs may be changed without affecting the levels at the outputs. These versatile flip-flops can perform as toggle flip-flops by grounding \bar{K} and tying J high. They also can perform as D-type flip-flops if J and \bar{K} are tied together.

The SN54HC109 is characterized for operation over the full military temperature range of -55°C to 125°C . The SN74HC109 is characterized for operation from -40°C to 85°C .

FUNCTION TABLE

INPUTS					OUTPUTS	
PRE	CLR	CLK	J	\bar{K}	Q	\bar{Q}
L	H	X	X	X	H	L
H	L	X	X	X	L	H
L	L	X	X	X	H [†]	H [†]
H	H	↑	L	L	L	H
H	H	↑	H	L	TOGGLE	TOGGLE
H	H	↑	L	H	Q ₀	\bar{Q}_0
H	H	↑	H	H	H	L
H	H	L	X	X	Q ₀	\bar{Q}_0

[†]This configuration is nonstable; that is, it will not persist when Preset or Clear return to their inactive (high) level.

SN54HC109 . . . J PACKAGE
SN74HC109 . . . D OR N PACKAGE
(TOP VIEW)

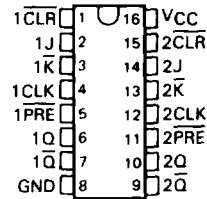

SN54HC109 . . . FK PACKAGE
(TOP VIEW)

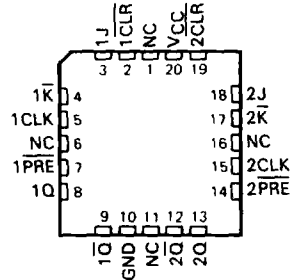

NC—No internal connection

logic symbol[†]

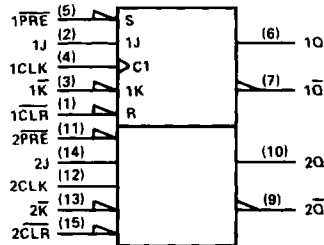

[†]This symbol is in accordance with ANSI/IEEE Std 91-1984 and IEC Publication 617-12. Pin numbers shown are for D, J, and N packages.

PRODUCTION DATA documents contain information current as of publication date. Products conform to specifications per the terms of Texas Instruments standard warranty. Production processing does not necessarily include testing of all parameters.



POST OFFICE BOX 655012 • DALLAS, TEXAS 75265

Copyright © 1989, Texas Instruments Incorporated

SN54HC109, SN74HC109
DUAL J-K POSITIVE-EDGE-TRIGGERED
FLIP-FLOPS WITH CLEAR AND PRESET

logic diagram, each flip-flop (positive logic)

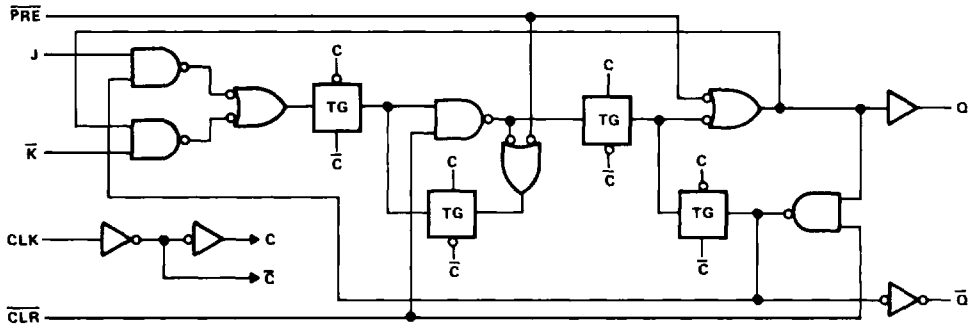

2
HC MOS Devices

absolute maximum ratings over operating free-air temperature †

Supply voltage, V_{CC}	-0.5 V to 7 V
Input clamp current, I_{IK} ($V_I < 0$ or $V_I > V_{CC}$)	± 20 mA
Output clamp current, I_{OK} ($V_O < 0$ or $V_O > V_{CC}$)	± 20 mA
Continuous output current, I_O ($V_O = 0$ to V_{CC})	± 25 mA
Continuous current through V_{CC} or GND pins	± 50 mA
Lead temperature 1,6 mm (1/16 in) from case for 60 s: FK or J package	300°C
Lead temperature 1,6 mm (1/16 in) from case for 10 s: D or N package	260°C
Storage temperature range	-65°C to 150°C

† Stresses beyond those listed under "absolute maximum ratings" may cause permanent damage to the device. These are stress ratings only, and functional operation of the device at these or any other conditions beyond those indicated under "recommended operating conditions" is not implied. Exposure to absolute-maximum-rated conditions for extended periods may affect device reliability.

recommended operating conditions

		SN54HC109			SN74HC109			UNIT
		MIN	NOM	MAX	MIN	NOM	MAX	
V_{CC} Supply voltage		2	5	6	2	5	6	V
V_{IH} High-level input voltage	$V_{CC} = 2$ V	1.5			1.5			V
	$V_{CC} = 4.5$ V	3.15			3.15			
	$V_{CC} = 6$ V	4.2			4.2			
V_{IL} Low-level input voltage	$V_{CC} = 2$ V	0		0.3	0		0.3	V
	$V_{CC} = 4.5$ V	0		0.9	0		0.9	
	$V_{CC} = 6$ V	0		1.2	0		1.2	
V_I Input voltage		0		V_{CC}	0		V_{CC}	V
V_O Output voltage		0		V_{CC}	0		V_{CC}	V
t_t Input transition (rise and fall) times	$V_{CC} = 2$ V	0		1000	0		1000	ns
	$V_{CC} = 4.5$ V	0		500	0		500	
	$V_{CC} = 6$ V	0		400	0		400	
T_A Operating free-air temperature		-55		125	-40		85	°C

SN54HC109, SN74HC109
DUAL J-K POSITIVE-EDGE-TRIGGERED
FLIP-FLOPS WITH CLEAR AND PRESET

electrical characteristics over recommended operating free-air temperature range (unless otherwise noted)

PARAMETER	TEST CONDITIONS	V _{CC}	T _A = 25°C			SN54HC109		SN74HC109		UNIT
			MIN	TYP	MAX	MIN	MAX	MIN	MAX	
V _{OH}	V _I = V _{IH} or V _{IL} , I _{OH} = -20 μA	2 V	1.9	1.998		1.9		1.9	V	
		4.5 V	4.4	4.499		4.4		4.4		
		6 V	5.9	5.999		5.9		5.9		
	V _I = V _{IH} or V _{IL} , I _{OH} = -4 mA	4.5 V	3.98	4.30		3.7		3.84		
	V _I = V _{IH} or V _{IL} , I _{OH} = -5.2 mA	6 V	5.48	5.80		5.2		5.34		
V _{OL}	V _I = V _{IH} or V _{IL} , I _{OL} = 20 μA	2 V		0.002	0.1		0.1		0.1	V
		4.5 V		0.001	0.1		0.1		0.1	
		6 V		0.001	0.1		0.1		0.1	
	V _I = V _{IH} or V _{IL} , I _{OL} = 4 mA	4.5 V		0.17	0.26		0.4		0.33	
	V _I = V _{IH} or V _{IL} , I _{OL} = 5.2 mA	6 V		0.15	0.26		0.4		0.33	
I _I	V _I = V _{CC} or 0	6 V		±0.1	±100		±1000		±1000	nA
I _{CC}	V _I = V _{CC} or 0, I _O = 0	6 V			4		80		40	μA
C _I		2 to 6 V		3	10		10		10	pF

timing requirements over recommended operating free-air temperature range (unless otherwise noted)

		V _{CC}	T _A = 25°C		SN54HC109		SN74HC109		UNIT
			MIN	MAX	MIN	MAX	MIN	MAX	
f _{clock}	Clock frequency	2 V	0	6	0	4.2	0	5	MHz
		4.5 V	0	31	0	21	0	25	
		6 V	0	36	0	25	0	29	
t _w	Pulse duration	PRE or CLR low	2 V	100		150		125	ns
			4.5 V	20		30		25	
			6 V	17		25		21	
		CLK high or low	2 V	80		120		100	
			4.5 V	16		24		20	
			6 V	14		20		17	
t _{su}	Setup time before CLK↑	Data (J, K)	2 V	100		150		125	ns
			4.5 V	20		30		25	
			6 V	17		25		21	
		PRE or CLR inactive	2 V	25		40		30	
			4.5 V	5		8		6	
			6 V	4		7		5	
t _h	Hold time, data after CLK↑	2 V	0		0		0	ns	
		4.5 V	0		0		0		
		6 V	0		0		0		

2
HC MOS Devices



SN54HC109, SN74HC109
DUAL J-K POSITIVE-EDGE-TRIGGERED
FLIP-FLOPS WITH CLEAR AND PRESET

switching characteristics over recommended operating free-air temperature range (unless otherwise noted), $C_L = 50$ pF (see Note 1)

PARAMETER	FROM (INPUT)	TO (OUTPUT)	V _{CC}	T _A = 25 °C			SN54HC109		SN74HC109		UNIT
				MIN	TYP	MAX	MIN	MAX	MIN	MAX	
f _{max}			2 V	6	10		4.2		5	MHz	
			4.5 V	31	50		21		25		
			6 V	36	60		25		29		
t _{pd}	PRE or \overline{CLR}	Q or \overline{Q}	2 V		60	230		345		290	ns
			4.5 V		15	46		69		58	
			6 V		12	39		59		49	
t _{pd}	CLK	Q or \overline{Q}	2 V		50	175		250		220	ns
			4.5 V		15	35		50		44	
			6 V		12	30		42		37	
t _t		Q or \overline{Q}	2 V		28	75		110		95	ns
			4.5 V		8	15		22		19	
			6 V		6	13		19		16	

C _{pd}	Power dissipation capacitance per flip-flop	No load, T _A = 25 °C	35 pF typ
-----------------	---	---------------------------------	-----------

NOTE 1: Load circuit and voltage waveforms are shown in Section 1.

2 HCMOS Devices