

AC245 • ACT245

54AC/74AC245 • 54ACT/74ACT245

Octal Bidirectional Transceiver With 3-State Inputs/Outputs

Description

The 'AC/'ACT245 contains eight non-inverting bidirectional buffers with 3-state outputs and is intended for bus-oriented applications. Current sinking capability is 24 mA at both the A and B ports. The Transmit/Receive (T/\bar{R}) input determines the direction of data flow through the bidirectional transceiver. Transmit (active-HIGH) enables data from A ports to B ports; Receive (active-LOW) enables data from B ports to A ports. The Output Enable input, when HIGH, disables both A and B ports by placing them in a High Z condition.

- Noninverting Buffers
- Bidirectional Data Path
- A and B Outputs Source/Sink 24 mA
- 'ACT245 has TTL-Compatible Inputs

Ordering Code: See Section 6

Pin Names

$\bar{O}E$	Output Enable Input
T/\bar{R}	Transmit/Receive Input
$A_0 - A_7$	Side A 3-State Inputs or 3-State Outputs
$B_0 - B_7$	Side B 3-State Inputs or 3-State Outputs

Truth Table

Inputs		Outputs
$\bar{O}E$	T/\bar{R}	
L	L	Bus B Data to Bus A
L	H	Bus A Data to Bus B
H	X	High Z State

H = HIGH Voltage Level
L = LOW Voltage Level
X = Immaterial

Connection Diagrams

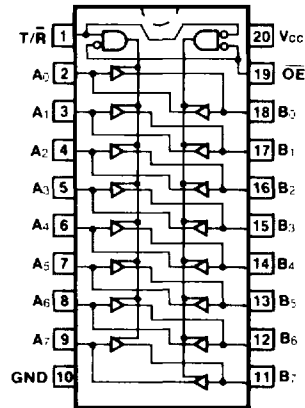

Pin Assignment for DIP, Flatpak and SOIC

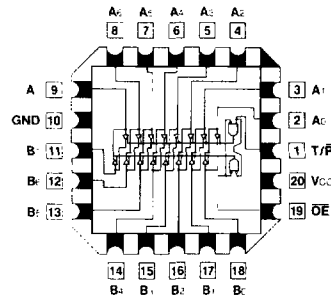

Pin Assignment for LCC

DC Characteristics (unless otherwise specified)

Symbol	Parameter	54AC/ACT	74AC/ACT	Units	Conditions
I _{CC}	Maximum Quiescent Supply Current	160	80	μA	V _{IN} = V _{CC} or Ground, V _{CC} = 5.5 V, T _A = Worst Case
I _{CC}	Maximum Quiescent Supply Current	8.0	8.0	μA	V _{IN} = V _{CC} or Ground, V _{CC} = 5.5 V, T _A = 25°C
I _{CC(T)}	Maximum Additional I _{CC} /Input (ACT245)	1.6	1.5	mA	V _{IN} = V _{CC} - 2.1 V, V _{CC} = 5.5 V, T _A = Worst Case

AC Characteristics

Symbol	Parameter	V _{CC} * (V)	74AC			54AC		74AC		Units	Fig. No.
			T _A = +25°C C _L = 50 pF			T _A = -55°C to +125°C C _L = 50 pF		T _A = -40°C to +85°C C _L = 50 pF			
			Min	Typ	Max	Min	Max	Min	Max		
t _{PLH}	Propagation Delay A _n to B _n or B _n to A _n	3.3 5.0	1.0 1.0	5.0 3.5	8.5 6.5	1.0 1.0	11.5 8.5	1.0 1.0	9.0 7.0	ns	3-5
t _{PHL}	Propagation Delay A _n to B _n or B _n to A _n	3.3 5.0	1.0 1.0	5.0 3.5	8.5 6.0	1.0 1.0	10.0 7.5	1.0 1.0	9.0 7.0	ns	3-5
t _{PZH}	Output Enable Time	3.3 5.0	1.0 1.0	7.0 5.0	11.5 8.5	1.0 1.0	13.5 10.0	1.0 1.0	12.5 9.0	ns	3-7
t _{PZL}	Output Enable Time	3.3 5.0	1.0 1.0	7.5 5.5	12.0 9.0	1.0 1.0	14.5 10.5	1.0 1.0	13.5 9.5	ns	3-8
t _{PHZ}	Output Disable Time	3.3 5.0	1.0 1.0	6.5 5.5	12.0 9.0	1.0 1.0	13.5 10.5	1.0 1.0	12.5 10.0	ns	3-7
t _{PLZ}	Output Disable Time	3.3 5.0	1.0 1.0	7.0 5.5	11.5 9.0	1.0 1.0	14.0 10.5	1.0 1.0	13.0 10.0	ns	3-8

*Voltage Range 3.3 is 3.3 V ± 0.3 V

Voltage Range 5.0 is 5.0 V ± 0.5 V

Military parameters given herein are for general references only. For current military specifications and subgroup testing information please request Fairchild's Table I data sheet from your Fairchild sales engineer or account representative.

AC245 • ACT245

AC Characteristics

Symbol	Parameter	V _{cc} * (V)	74ACT			54ACT		74ACT		Units	Fig. No.
			T _A = +25°C C _L = 50 pF			T _A = -55°C to +125°C C _L = 50 pF		T _A = -40°C to +85°C C _L = 50 pF			
			Min	Typ	Max	Min	Max	Min	Max		
t _{PLH}	Propagation Delay A _n to B _n or B _n to A _n	5.0	1.0	4.0	7.5	1.0	9.0	1.0	8.0	ns	3-5
t _{PHL}	Propagation Delay A _n to B _n or B _n to A _n	5.0	1.0	4.0	8.0	1.0	10.0	1.0	9.0	ns	3-5
t _{PZH}	Output Enable Time	5.0	1.0	5.0	10.0	1.0	12.0	1.0	11.0	ns	3-7
t _{PZL}	Output Enable Time	5.0	1.0	5.5	10.0	1.0	13.0	1.0	12.0	ns	3-8
t _{PHZ}	Output Disable Time	5.0	1.0	5.5	10.0	1.0	12.0	1.0	11.0	ns	3-7
t _{PLZ}	Output Disable Time	5.0	1.0	5.0	10.0	1.0	12.0	1.0	11.0	ns	3-8

*Voltage Range 5.0 is 5.0 V ± 0.5 V

Military parameters given herein are for general references only. For current military specifications and subgroup testing information please request Fairchild's Table I data sheet from your Fairchild sales engineer or account representative.

Capacitance

Symbol	Parameter	54/74AC/ACT	Units	Conditions
		Typ		
C _{IN}	Input Capacitance	4.5	pF	V _{cc} = 5.5 V
C _{I/O}	Input/Output Capacitance	15.0	pF	V _{cc} = 5.5 V
C _{PD}	Power Dissipation Capacitance	45.0	pF	V _{cc} = 5.5 V