

SN54ALS169B, SN54AS169A, SN74ALS169B, SN74AS169A SYNCHRONOUS 4-BIT UP/DOWN BINARY COUNTERS

SDAS125B - MARCH 1984 - REVISED DECEMBER 1994

- Fully Synchronous Operation for Counting and Programming
- Internal Carry Look-Ahead Circuitry for Fast Counting
- Carry Output for n-Bit Cascading
- Fully Independent Clock Circuit
- Package Options Include Plastic Small-Outline (D) Packages, Ceramic Chip Carriers (FK), and Standard Plastic (N) and Ceramic (J) 300-mil DIPs

These synchronous 4-bit up/down binary presetable counters feature an internal carry look-ahead circuitry for cascading in high-speed counting applications. Synchronous operation is provided by having all flip-flops clocked simultaneously so that the outputs change coincident with each other when so instructed by the count-enable ($\overline{\text{ENP}}$, $\overline{\text{ENT}}$) inputs and internal gating. This mode of operation eliminates the output counting spikes normally associated with asynchronous (ripple-clock) counters. A buffered clock (CLK) input triggers the four flip-flops on the rising (positive-going) edge of the clock waveform.

These counters are fully programmable; that is, they may be preset to either level. The load-input circuitry allows loading with the carry-enable output of cascaded counters. Because loading is synchronous, setting up a low level at the load ($\overline{\text{LOAD}}$) input disables the counter and causes the outputs to agree with the data inputs after the next clock pulse.

The internal carry look-ahead circuitry provides for cascading counters for n-bit synchronous application without additional gating. $\overline{\text{ENP}}$ and $\overline{\text{ENT}}$ inputs and a ripple-carry output ($\overline{\text{RCO}}$) are instrumental in accomplishing this function. Both $\overline{\text{ENP}}$ and $\overline{\text{ENT}}$ must be low to count. The direction of the count is determined by the level of the up/down ($\overline{\text{U/D}}$) input. When $\overline{\text{U/D}}$ is high, the counter counts up; when low, it counts down. $\overline{\text{ENT}}$ is fed forward to enable $\overline{\text{RCO}}$. $\overline{\text{RCO}}$, thus enabled, produces a low-level pulse while the count is zero (all inputs low) counting down or maximum (15) counting up. This low-level overflow ripple-carry pulse can be used to enable successive cascaded stages. Transitions at $\overline{\text{ENP}}$ or $\overline{\text{ENT}}$ are allowed regardless of the level of the clock input. All inputs are diode clamped to minimize transmission-line effects, thereby simplifying system design.

These counters feature a fully independent clock circuit. Changes at control inputs ($\overline{\text{ENP}}$, $\overline{\text{ENT}}$, $\overline{\text{LOAD}}$, or $\overline{\text{U/D}}$) that modify the operating mode have no effect on the contents of the counter until clocking occurs. The function of the counter (whether enabled, disabled, loading, or counting) is dictated solely by the conditions meeting the stable setup and hold times.

The SN54ALS169B and SN54AS169A are characterized for operation over the full military temperature range of -55°C to 125°C . The SN74ALS169B and SN74AS169A are characterized for operation from 0°C to 70°C .

SN54ALS169B, SN54AS169A ... J PACKAGE
SN74ALS169B, SN74AS169A ... D OR N PACKAGE
(TOP VIEW)

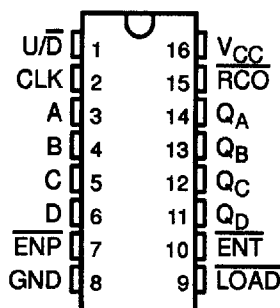

SN54ALS169B, SN54AS169A ... FK PACKAGE
(TOP VIEW)

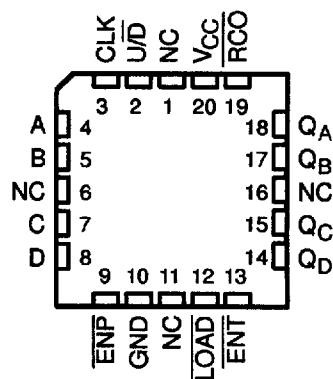

NC - No internal connection

SN54ALS169B, SN54AS169A, SN74ALS169B, SN74AS169A SYNCHRONOUS 4-BIT UP/DOWN BINARY COUNTERS

SDAS125B - MARCH 1984 - REVISED DECEMBER 1994

logic symbol†

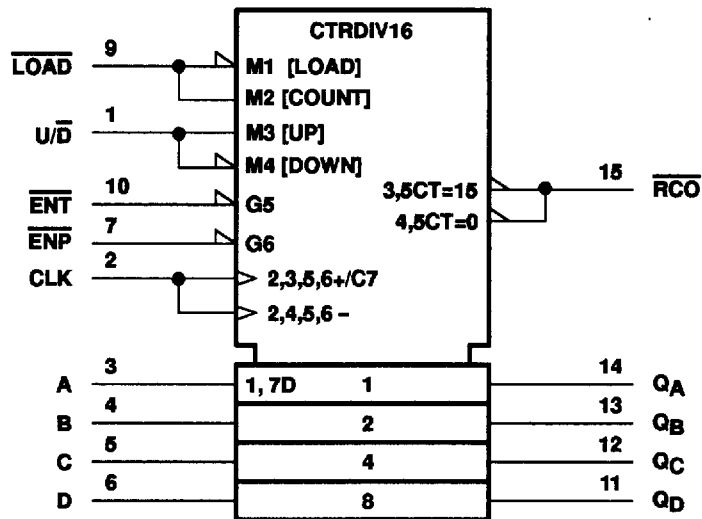

† This symbol is in accordance with ANSI/IEEE Std 91-1984 and IEC Publication 617-12.
Pin numbers shown are for the D, J, and N packages.



POST OFFICE BOX 655303 • DALLAS, TEXAS 75265

8961723 0103692 97T

SN54ALS169B, SN54AS169A, SN74ALS169B, SN74AS169A SYNCHRONOUS 4-BIT UP/DOWN BINARY COUNTERS

SDAS125B - MARCH 1984 - REVISED DECEMBER 1994

logic diagram (positive logic)

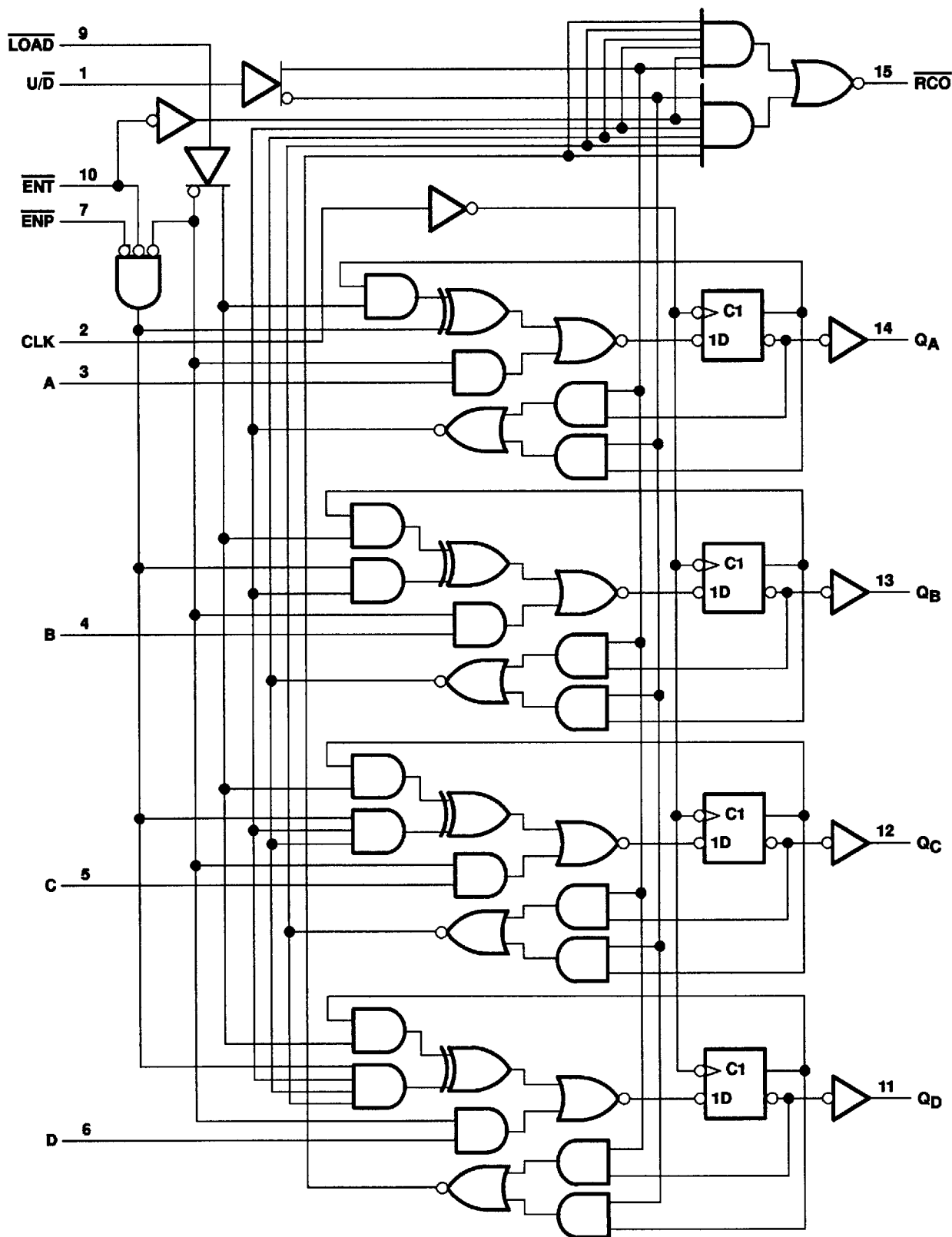

Pin numbers shown are for the D, J, and N packages.



POST OFFICE BOX 655303 • DALLAS, TEXAS 75265

8961723 0103693 806

SN54ALS169B, SN54AS169A, SN74ALS169B, SN74AS169A SYNCHRONOUS 4-BIT UP/DOWN BINARY COUNTERS

SDAS125B - MARCH 1984 - REVISED DECEMBER 1994

typical load, count, and inhibit sequences

The following sequence is illustrated below:

1. Load (preset) to binary 13
2. Count up to 14, 15 (maximum), 0, 1, and 2
3. Inhibit
4. Count down to 1, 0 (minimum), 15, 14, and 13

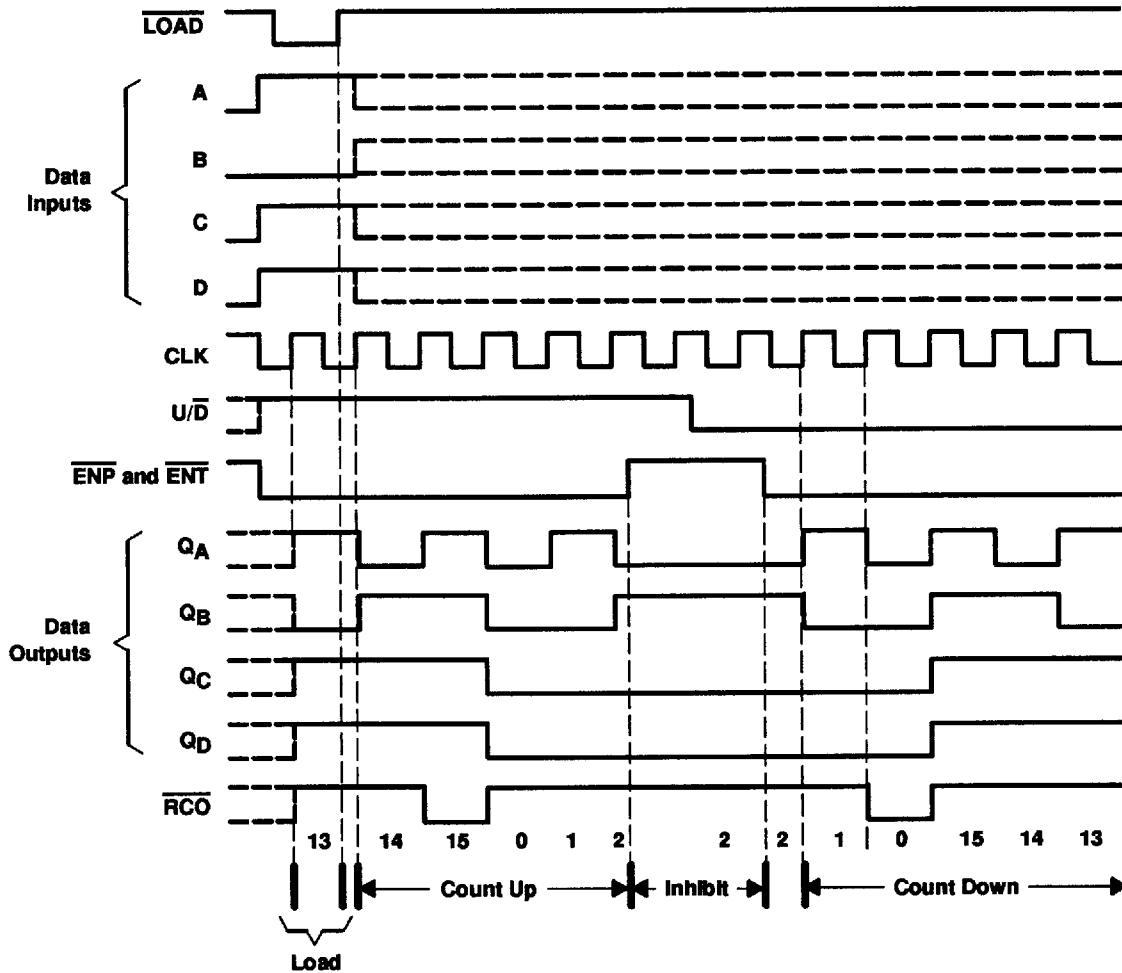

absolute maximum ratings over operating free-air temperature range (unless otherwise noted)†

Supply voltage, V_{CC}	7 V
Input voltage, V_I	7 V
Operating free-air temperature range, T_A : SN54ALS169B	-55°C to 125°C
SN74ALS169B	0°C to 70°C
Storage temperature range	-65°C to 150°C

† Stresses beyond those listed under "absolute maximum ratings" may cause permanent damage to the device. These are stress ratings only, and functional operation of the device at these or any other conditions beyond those indicated under "recommended operating conditions" is not implied. Exposure to absolute-maximum-rated conditions for extended periods may affect device reliability.



POST OFFICE BOX 655303 • DALLAS, TEXAS 75265

8961723 0103694 742

SN54ALS169B, SN54AS169A, SN74ALS169B, SN74AS169A SYNCHRONOUS 4-BIT UP/DOWN BINARY COUNTERS

SDAS125B - MARCH 1984 - REVISED DECEMBER 1994

recommended operating conditions

		SN54ALS169B			SN74ALS169B			UNIT
		MIN	NOM	MAX	MIN	NOM	MAX	
V _{CC}	Supply voltage	4.5	5	5.5	4.5	5	5.5	V
V _{IH}	High-level input voltage	2			2			V
V _{IL}	Low-level input voltage			0.7			0.8	V
I _{OH}	High-level output current			-0.4			-0.4	mA
I _{OL}	Low-level output current			4			8	mA
f _{clock}	Clock frequency	0		22	0		40	MHz
t _w	Pulse duration, CLK high or low	14			12.5			ns
t _{su}	Setup time before CLK↑	A, B, C, or D		20	15		ns	
		ENP or ENT		25	15			
		LOAD		20	15			
		U/D		28	15			
t _h	Hold time, data after CLK↑	0			0		ns	
T _A	Operating free-air temperature	-55		125	0		70	°C

electrical characteristics over recommended operating free-air temperature range (unless otherwise noted)

PARAMETER	TEST CONDITIONS	SN54ALS169B		SN74ALS169B		UNIT		
		MIN	TYP†	MAX	MIN		TYP†	MAX
V _{IK}	V _{CC} = 4.5 V, I _I = -18 mA			-1.5		-1.5	V	
V _{OH}	V _{CC} = 4.5 V to 5.5 V, I _{OH} = -0.4 mA	V _{CC} - 2		V _{CC} - 2		V		
V _{OL}	V _{CC} = 4.5 V	I _{OL} = 4 mA		0.25	0.4	0.25	0.4	V
		I _{OL} = 8 mA				0.35	0.5	
I _I	V _{CC} = 5.5 V, V _I = 7 V			0.1		0.1	mA	
I _{IH}	V _{CC} = 5.5 V, V _I = 2.7 V			20		20	μA	
I _{IL}	V _{CC} = 5.5 V, V _I = 0.4 V			-0.2		-0.2	mA	
I _{O‡}	V _{CC} = 5.5 V, V _O = 2.25 V	-20		-112	-30	-112	mA	
I _{CC}	V _{CC} = 5.5 V		15	25		15	25	mA

† All typical values are at V_{CC} = 5 V, T_A = 25°C.

‡ The output conditions have been chosen to produce a current that closely approximates one half of the true short-circuit output current, I_{OS}.



POST OFFICE BOX 655303 • DALLAS, TEXAS 75265

8961723 0103695 689

SN54ALS169B, SN54AS169A, SN74ALS169B, SN74AS169A SYNCHRONOUS 4-BIT UP/DOWN BINARY COUNTERS

SDAS125B - MARCH 1984 - REVISED DECEMBER 1994

switching characteristics (see Figure 1)

PARAMETER	FROM (INPUT)	TO (OUTPUT)	V _{CC} = 4.5 V to 5.5 V, C _L = 50 pF, R _L = 500 Ω, T _A = MIN to MAX†				UNIT
			SN54ALS169B		SN74ALS169B		
			MIN	MAX	MIN	MAX	
f _{max}			22		40		MHz
t _{PLH}	CLK	\overline{RCO}	3	20	3	20	ns
t _{PHL}			6	25	6	20	
t _{PLH}	CLK	Any Q	2	20	2	15	ns
t _{PHL}			5	23	5	20	
t _{PLH}	\overline{ENT}	\overline{RCO}	2	16	2	13	ns
t _{PHL}			3	24	3	16	
t _{PLH}	U/ \overline{D}	\overline{RCO}	4	22	5	19	ns
t _{PHL}			5	26	5	19	

† For conditions shown as MIN or MAX, use the appropriate value specified under recommended operating conditions.

absolute maximum ratings over operating free-air temperature range (unless otherwise noted)‡

Supply voltage, V _{CC}	7 V
Input voltage, V _I	7 V
Operating free-air temperature range, T _A : SN54AS169A	-55°C to 125°C
SN74AS169A	0°C to 70°C
Storage temperature range	-65°C to 150°C

‡ Stresses beyond those listed under "absolute maximum ratings" may cause permanent damage to the device. These are stress ratings only, and functional operation of the device at these or any other conditions beyond those indicated under "recommended operating conditions" is not implied. Exposure to absolute-maximum-rated conditions for extended periods may affect device reliability.

recommended operating conditions

	SN54AS169A			SN74AS169A			UNIT
	MIN	NOM	MAX	MIN	NOM	MAX	
V _{CC} Supply voltage	4.5	5	5.5	4.5	5	5.5	V
V _{IH} High-level input voltage	2			2			V
V _{IL} Low-level input voltage			0.8			0.8	V
I _{OH} High-level output current			-2			-2	mA
I _{OL} Low-level output current			20			20	mA
f _{clock} * Clock frequency	0		60	0		75	MHz
t _w * Pulse duration, CLK high or low	7.7			6.7			ns
t _{su} * Setup time before CLK↑	A, B, C, or D	10		8			ns
	\overline{ENP} or \overline{ENT}	10		8			
	LOAD	10		8			
	U/ \overline{D}	14		11			
t _h * Hold time, data after CLK↑	2			0			ns
T _A Operating free-air temperature	-55		125	0		70	°C

* On products compliant to MIL-STD-883, Class B, this parameter is based on characterization data but is not production tested.



POST OFFICE BOX 655303 • DALLAS, TEXAS 75265

SN54ALS169B, SN54AS169A, SN74ALS169B, SN74AS169A SYNCHRONOUS 4-BIT UP/DOWN BINARY COUNTERS

SDAS125B - MARCH 1984 - REVISED DECEMBER 1994

electrical characteristics over recommended operating free-air temperature range (unless otherwise noted)

PARAMETER	TEST CONDITIONS	SN54AS169A			SN74AS169A			UNIT
		MIN	TYP†	MAX	MIN	TYP†	MAX	
V _{IK}	V _{CC} = 4.5 V, I _I = -18 mA			-1.2			-1.2	V
V _{OH}	V _{CC} = 4.5 V to 5.5 V, I _{OH} = -2 mA	V _{CC} - 2			V _{CC} - 2			V
V _{OL}	V _{CC} = 4.5 V, I _{OL} = 20 mA	0.25	0.5		0.25	0.5		V
I _I	LOAD, ENT, U/D	V _{CC} = 5.5 V, V _I = 7 V			0.2			mA
	All others				0.1			
I _{IH}	LOAD, ENT, U/D	V _{CC} = 5.5 V, V _I = 2.7 V			40			μA
	All others				20			
I _{IL}	LOAD, ENT, U/D	V _{CC} = 5.5 V, V _I = 0.4 V			-1			mA
	All others				-0.5			
I _{O‡}	V _{CC} = 5.5 V, V _O = 2.25 V	-30		-112	-30		-112	mA
I _{CC}	V _{CC} = 5.5 V		41	63		41	63	mA

† All typical values are at V_{CC} = 5 V, T_A = 25°C.

‡ The output conditions have been chosen to produce a current that closely approximates one half of the true short-circuit output current, I_{OS}.

switching characteristics (see Figure 1)

PARAMETER	FROM (INPUT)	TO (OUTPUT)	V _{CC} = 4.5 V to 5.5 V, C _L = 50 pF, R _L = 500 Ω, T _A = MIN to MAX§				UNIT
			SN54AS169A		SN74AS169A		
			MIN	MAX	MIN	MAX	
f _{max} *			60		75	MHz	
t _{PLH}	CLK	\overline{RCO} (LOAD high or low)	3	17.5	3	16.5	ns
t _{PHL}			2	14	2	13	
t _{PLH}	CLK	Any Q	1	7.5	1	7	ns
t _{PHL}			2	14	2	13	
t _{PLH}	\overline{ENT}	\overline{RCO}	1.5	10	1.5	9	ns
t _{PHL}			1.5	10	1.5	9	
t _{PLH}	U/ \overline{D}	\overline{RCO}	2	14	2	12	ns
t _{PHL}			2	14.5	2	13	

* On products compliant to MIL-STD-883, Class B, this parameter is based on characterization data but is not production tested.

§ For conditions shown as MIN or MAX, use the appropriate value specified under recommended operating conditions.



POST OFFICE BOX 655303 • DALLAS, TEXAS 75265

SN54ALS169B, SN54AS169A, SN74ALS169B, SN74AS169A SYNCHRONOUS 4-BIT UP/DOWN BINARY COUNTERS

SDAS125B - MARCH 1984 - REVISED DECEMBER 1994

PARAMETER MEASUREMENT INFORMATION SERIES 54ALS/74ALS AND 54AS/74AS DEVICES

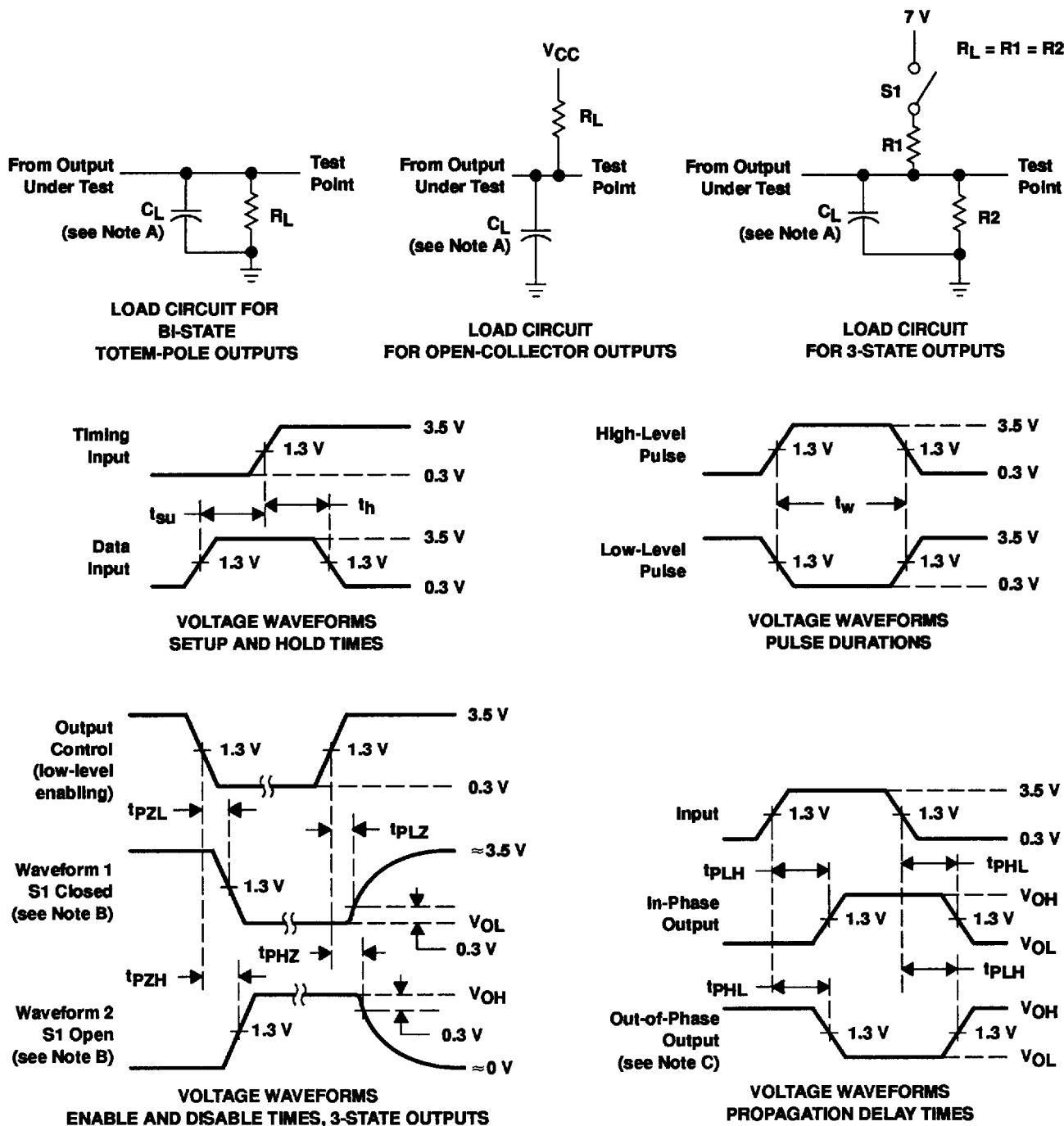

NOTES: A. C_L includes probe and jig capacitance.

B. Waveform 1 is for an output with internal conditions such that the output is low except when disabled by the output control. Waveform 2 is for an output with internal conditions such that the output is high except when disabled by the output control.

C. When measuring propagation delay items of 3-state outputs, switch S1 is open.

D. All input pulses have the following characteristics: $PRR \leq 1$ MHz, $t_r = t_f = 2$ ns, duty cycle = 50%.

E. The outputs are measured one at a time with one transition per measurement.

Figure 1. Load Circuits and Voltage Waveforms

 **TEXAS
INSTRUMENTS**

POST OFFICE BOX 655303 • DALLAS, TEXAS 75265