

DESCRIPTION

The SG1844/45 family of control ICs provides all the necessary features to implement off-line fixed frequency, current-mode switching power supplies with a minimum number of external components. Current-mode architecture demonstrates improved line regulation, improved load regulation, pulse-by-pulse current limiting and inherent protection of the power supply output switch. The bandgap reference is trimmed to $\pm 1\%$ over temperature. Oscillator discharge current is trimmed to less than $\pm 10\%$. The SG1844/45 has undervoltage lockout, current-limiting circuitry

and start-up current of less than 1mA. The totem-pole output is optimized to drive the gate of a power MOSFET. The output is low in the off state to provide direct interface to an N-channel device. Both operate up to a maximum duty cycle range of zero to $<50\%$ due to an internal toggle flip-flop which blanks the output off every other clock cycle. The SG1844/45 is specified for operation over the full military ambient temperature range of -55°C to 125°C . The SG2844/45 is specified for the industrial range of -25°C to 85°C , and the SG3844/45 is designed for the commercial range of 0°C to 70°C .

IMPORTANT: For the most current data, consult MICROSEMI's website: <http://www.microsemi.com>

KEY FEATURES

- OPTIMIZED FOR OFF-LINE CONTROL
- LOW START-UP CURRENT ($<1\text{mA}$)
- AUTOMATIC FEED FORWARD COMPENSATION
- TRIMMED OSCILLATOR DISCHARGE CURRENT
- PULSE-BY-PULSE CURRENT LIMITING
- ENHANCED LOAD RESPONSE CHARACTERISTICS
- UNDER-VOLTAGE LOCKOUT WITH 6V HYSTERESIS (SG1844 only)
- DOUBLE PULSE SUPPRESSION
- HIGH-CURRENT TOTEM-POLE OUTPUT
- INTERNALLY TRIMMED BANDGAP REFERENCE
- 500kHz OPERATION
- UNDERVOLTAGE LOCKOUT SG1844 - 16 volts SG1845 - 8.4 volts
- LOW SHOOT-THROUGH CURRENT $<75\text{mA}$ OVER TEMPERATURE

PRODUCT HIGHLIGHT

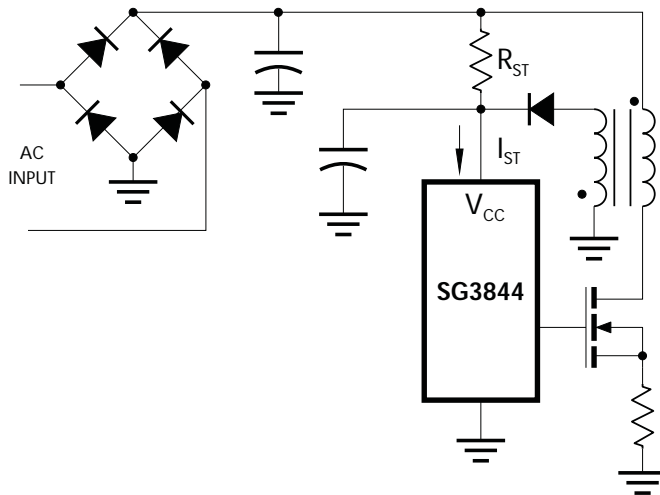

HIGH RELIABILITY FEATURES

- AVAILABLE TO MIL-STD-883B
- LINFINITY LEVEL "S" PROCESSING AVAILABLE

PACKAGE ORDER INFO

T _A (°C)	M	N	DM	D	Y	J	F	L
	Plastic DIP 8-Pin RoHS Compliant / Pb-free Transition DC: 0503	Plastic DIP 14-Pin RoHS Compliant / Pb-free Transition DC: 0503	Plastic SOIC 8-Pin RoHS Compliant / Pb-free Transition DC: 0440	Plastic SOIC 14-Pin RoHS Compliant / Pb-free Transition DC: 0440	Ceramic Dip 8-Pin	Ceramic DIP 14-Pin	Cer Flatpack 10-Pin	Ceramic LCC 20-Pin
0 to 70	SG3844M	SG3844N	SG3844DM	SG3844D	SG3844Y	SG3844J		
	SG3845M	SG3845N	SG3845DM	SG3845D	SG3845Y	SG3845J		
-25 to 85	SG2844M	SG28424N	SG2844DM	SG2842D	SG2844Y	SG2844J		
	SG2845M	SG2845N	SG2845DM	SG2845D	SG2845Y	SG2845J		
-55 to 125					SG1844Y	SG1844J		SG1844L
					SG1845Y	SG1845J		SG1845L
MIL-STD/883					SG1842Y/883B	SG1844J/883B		SG1844L/883B
					SG1845Y/883B	SG1845J/883B		SG1845L/883B
DESC					SG1844Y/DESC	SG1844J/DESC	SG1844F/DESC	SG1844L/DESC

Note: Available in Tape & Reel. Append the letters "TR" to the part number. (i.e. LXSG3844N-TR)

SG1844/SG1845 Series

CURRENT-MODE PWM CONTROLLER

PRODUCTION DATA SHEET

ABSOLUTE MAXIMUM RATINGS (Notes 1 & 2)

Supply Voltage ($I_{CC} < 30\text{mA}$)	Self Limiting
Supply Voltage (Low Impedance Source)	30V
Output Current (Peak)	$\pm 1\text{A}$
Output Current (Continuous)	350mA
Output Energy (Capacitive Load)	5 μJ
Analog Inputs (V_{FB} , I_{SENSE})	-0.3V to +6.3V
Error Amp Output Sink Current	10mA
Operating Junction Temperature	
Hermetic (J, Y, F, L Packages)	150°C
Plastic (N, M, D, DM Packages)	150°C
Storage Temperature Range	-65°C to +150°C
Lead Temperature (Soldering, 10 Seconds)	300°C
RoHS / Pb-free Peak Package Solder Reflow Temp. (40 second max. exposure)	260°C (+0, -5)

Note 1. Exceeding these ratings could cause damage to the device.

Note 2. All voltages are with respect to Pin 5. All currents are positive into the specified terminal.

THERMAL DATA

M PACKAGE:

THERMAL RESISTANCE-JUNCTION TO AMBIENT, θ_{JA}	95°C/W
---	--------

N PACKAGE:

THERMAL RESISTANCE-JUNCTION TO AMBIENT, θ_{JA}	65°C/W
---	--------

DM PACKAGE:

THERMAL RESISTANCE-JUNCTION TO AMBIENT, θ_{JA}	165°C/W
---	---------

D PACKAGE:

THERMAL RESISTANCE-JUNCTION TO AMBIENT, θ_{JA}	120°C/W
---	---------

Y PACKAGE:

THERMAL RESISTANCE-JUNCTION TO AMBIENT, θ_{JA}	130°C/W
---	---------

J PACKAGE:

THERMAL RESISTANCE-JUNCTION TO AMBIENT, θ_{JA}	80°C/W
---	--------

F PACKAGE:

THERMAL RESISTANCE-JUNCTION TO CASE, θ_{JC}	80°C/W
THERMAL RESISTANCE-JUNCTION TO AMBIENT, θ_{JA}	145°C/W

L PACKAGE:

THERMAL RESISTANCE-JUNCTION TO CASE, θ_{JC}	35°C/W
THERMAL RESISTANCE-JUNCTION TO AMBIENT, θ_{JA}	120°C/W

Junction Temperature Calculation: $T_J = T_A + (P_D \times \theta_{JA})$.

The θ_{JA} numbers are guidelines for the thermal performance of the device/pc-board system. All of the above assume no ambient airflow.

PACKAGE PIN OUTS

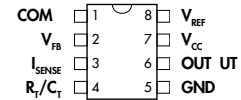

M & Y PACKAGE

(Top View)

M Package: RoHS / Pb-free 100% Matte Tin Lead Finish

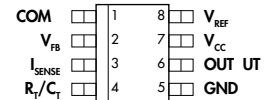

DM PACKAGE

(Top View)

RoHS / Pb-free 100% Matte Tin Lead Finish

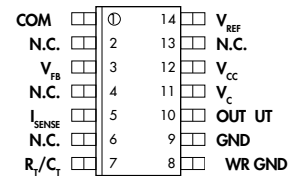

D PACKAGE

(Top View)

RoHS / Pb-free 100% Matte Tin Lead Finish

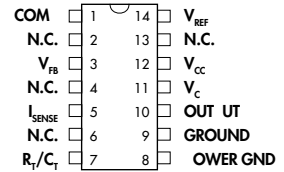

J & N PACKAGE

(Top View)

N Package: RoHS / Pb-free 100% Matte Tin Lead Finish

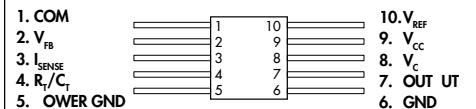

F PACKAGE

(Top View)

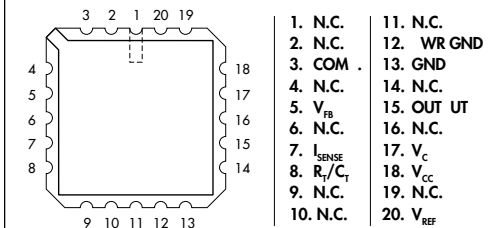

L PACKAGE

(Top View)

CURRENT-MODE PWM CONTROLLER

PRODUCTION DATA SHEET

RECOMMENDED OPERATING CONDITIONS (Note 3)

Parameter	Symbol	Recommended Operating Conditions			Units
		Min.	Typ.	Max.	
Supply Voltage Range			30		V
Output Current (Peak)			±1		A
Output Current (Continuous)			200		mA
Analog Inputs (Pin 2, Pin 3)		0		2.6	V
Error Amp Output Sink Current			5		mA
Oscillator Frequency Range		0.1		500	kHz
Oscillator Timing Resistor	R_T	0.52		150	k Ω
Oscillator Timing Capacitor	C_T	0.001		1.0	μ F
Operating Ambient Temperature Range:					
SG1844/45		-55		125	$^{\circ}$ C
SG2844/45		-25		85	$^{\circ}$ C
SG3844/45		0		70	$^{\circ}$ C

Note 3. Range over which the device is functional.

ELECTRICAL CHARACTERISTICS

(Unless otherwise specified, these specifications apply over the operating ambient temperatures for SG1844/SG1845 with $-55^{\circ}\text{C} \leq T_A \leq 125^{\circ}\text{C}$, SG2844/SG2845 with $-25^{\circ}\text{C} \leq T_A \leq 85^{\circ}\text{C}$, SG3844/SG3845 with $0^{\circ}\text{C} \leq T_A \leq 70^{\circ}\text{C}$, $V_{CC} = 15\text{V}$ (Note 7), $R_T = 10\text{k}\Omega$, and $C_T = 3.3\text{nF}$. Low duty cycle pulse testing techniques are used which maintains junction and case temperatures equal to the ambient temperature.)

Parameter	Symbol	Test Conditions	SG1844/45			SG2844/45			SG3844/45			Units
			Min.	Typ.	Max.	Min.	Typ.	Max.	Min.	Typ.	Max.	
Reference Section												
Output Voltage		$T_J = 25^{\circ}\text{C}$, $I_O = 1\text{mA}$	4.95	5.00	5.05	4.95	5.00	5.05	4.90	5.00	5.10	V
Line Regulation		$12 \leq V_{IN} \leq 25\text{V}$		6	20		6	20		6	20	mV
Load Regulation		$1 \leq I_O \leq 20\text{mA}$		6	25		6	25		6	25	mV
Temperature Stability (Note 4)				0.2	0.4		0.2	0.4		0.2	0.4	mV/ $^{\circ}$ C
Total Output Variation (Note 4)		Line, Load, Temp.	4.90		5.10	4.90		5.10	4.82		5.18	V
Output Noise Voltage (Note 4)	V_N	$10\text{Hz} \leq f \leq 10\text{kHz}$, $T_J = 25^{\circ}\text{C}$		50			50			50		μ V
Long Term Stability (Note 4)		$T_A = 125^{\circ}\text{C}$, 1000hrs		5	25		5	25		5	25	mV
Output Short Circuit			-30	-100	-180	-30	-100	-180	-30	-100	-180	mA
Oscillator Section												
Initial Accuracy (Note 8)		$T_J = 25^{\circ}\text{C}$	47	52	57	47	52	57	47	52	57	kHz
Voltage Stability		$12\text{V} \leq V_{CC} \leq 25\text{V}$.02	1		0.2	1		0.2	1	%
Temperature Stability (Note 4)		$T_{MIN} \leq T_A \leq T_{MAX}$		5			5			5		%
Amplitude		$V_{RT/CT}$ (Peak to Peak)		1.7			1.7			1.7		V
Discharge Current		$T_J = 25^{\circ}\text{C}$	7.8	8.3	9.1	7.5	8.4	9.3	7.5	8.4	9.3	mA
		$T_{MIN} \leq T_A \leq T_{MAX}$	6.8		9.3	7.2		9.5	7.2		9.5	mA
Error Amp Section												
Input Voltage		$V_{COMP} = 2.5\text{V}$	2.45	2.50	2.55	2.45	2.50	2.55	2.42	2.50	2.58	V
Input Bias Current				-0.3	-1		-0.3	1		-0.3	-2	μ A
Open Loop Gain	A_{VOL}	$2 \leq V_O \leq 4\text{V}$	65	90		65	90		65	90		dB
Unity Gain Bandwidth (Note 4)		$T_J = 25^{\circ}\text{C}$	0.7	1		0.7	1		0.7	1		MHz
Power Supply Rejection Ratio	PSRR	$12 \leq V_{CC} \leq 25\text{V}$	60	70		60	70		60	70		dB
Output Sink Current		$V_{VFB} = 2.7\text{V}$, $V_{COMP} = 1.1\text{V}$	2	6		2	6		2	6		mA
Output Source Current		$V_{VFB} = 2.3\text{V}$, $V_{COMP} = 5\text{V}$	-0.5	-0.8		-0.5	-0.8		-0.5	-0.8		mA
V_{OUT} High		$V_{VFB} = 2.3\text{V}$, $R_L = 15\text{K}$ to gnd	5	6		5	6		5	6		V
V_{OUT} Low		$V_{VFB} = 2.7\text{V}$, $R_L = 15\text{K}$ to V_{REF}		0.7	1.1		0.7	1.1		0.7	1.1	V

(Electrical Characteristics continue next page.)

SG1844/SG1845 Series

CURRENT-MODE PWM CONTROLLER

PRODUCTION DATA SHEET

ELECTRICAL CHARACTERISTICS (Cont'd.)

Parameter	Symbol	Test Conditions	SG1844/45			SG2844/45			SG3844/45			Units
			Min.	Typ.	Max.	Min.	Typ.	Max.	Min.	Typ.	Max.	
Current Sense Section												
Gain (Notes 5 & 6)			2.85	3	3.15	2.85	3	3.15	2.85	3	3.15	V/V
Maximum Input Signal (Note 5)		$V_{COMP} = 5V$	0.9	1	1.1	0.9	1	1.1	0.9	1	1.1	V
Power Supply Rejection Ratio (Note 5)	PSRR	$12 \leq V_{CC} \leq 25V$		70			70			70		dB
Input Bias Current				-2	-10		-2	-10		-2	-10	μA
Delay to Output (Note 4)				150	300		150	300		150	300	ns
Output Section												
Output Low Level		$I_{SINK} = 20mA$		0.1	0.4		0.1	0.4		0.1	0.4	V
		$I_{SINK} = 200mA$		1.5	2.2		1.5	2.2		1.5	2.2	V
Output High Level		$I_{SOURCE} = 20mA$	13	13.5		13	13.5		13	13.5		V
		$I_{SOURCE} = 200mA$	12	13.5		12	13.5		12	13.5		V
Rise Time (Note 4)		$T_J = 25^\circ C, C_L = 1nF$		50	150		50	150		50	150	ns
Fall Time (Note 4)		$T_J = 25^\circ C, C_L = 1nF$		50	150		50	150		50	150	ns
Under-Voltage Lockout Section												
Start Threshold		1844	15	16	17	15	16	17	14.5	16	17.5	V
		1845	7.8	8.4	9.0	7.8	8.4	9.0	7.8	8.4	9.0	V
Min. Operation Voltage After Turn-On		1844	9	10	11	9	10	11	8.5	10	11.5	V
		1845	7.0	7.6	8.3	7.0	7.6	8.2	7.0	7.6	8.2	V
PWM Section												
Maximum Duty Cycle			46	48	50	46	48	50	46	48	50	%
Minimum Duty Cycle					0			0			0	%
Power Consumption Section												
Start-Up Current				0.5	1		0.5	1		0.5	1	mA
Operating Supply Current		$V_{FB} = V_{ISENSE} = 0V$		11	17		11	17		11	17	mA
V_{CC} Zener Voltage		$I_{CC} = 25mA$		34			34			34		V

Notes: 4. These parameters, although guaranteed, are not 100% tested in production.

5. Parameter measured at trip point of latch with $V_{VFB} = 0$.

6. Gain defined as: $A = \frac{\Delta V_{COMP}}{\Delta V_{ISENSE}}$; $0 \leq V_{ISENSE} \leq 0.8V$.

7. Adjust V_{CC} above the start threshold before setting at 15V.

8. Output frequency equals one half of oscillator frequency.

CURRENT-MODE PWM CONTROLLER

PRODUCTION DATA SHEET

BLOCK DIAGRAM

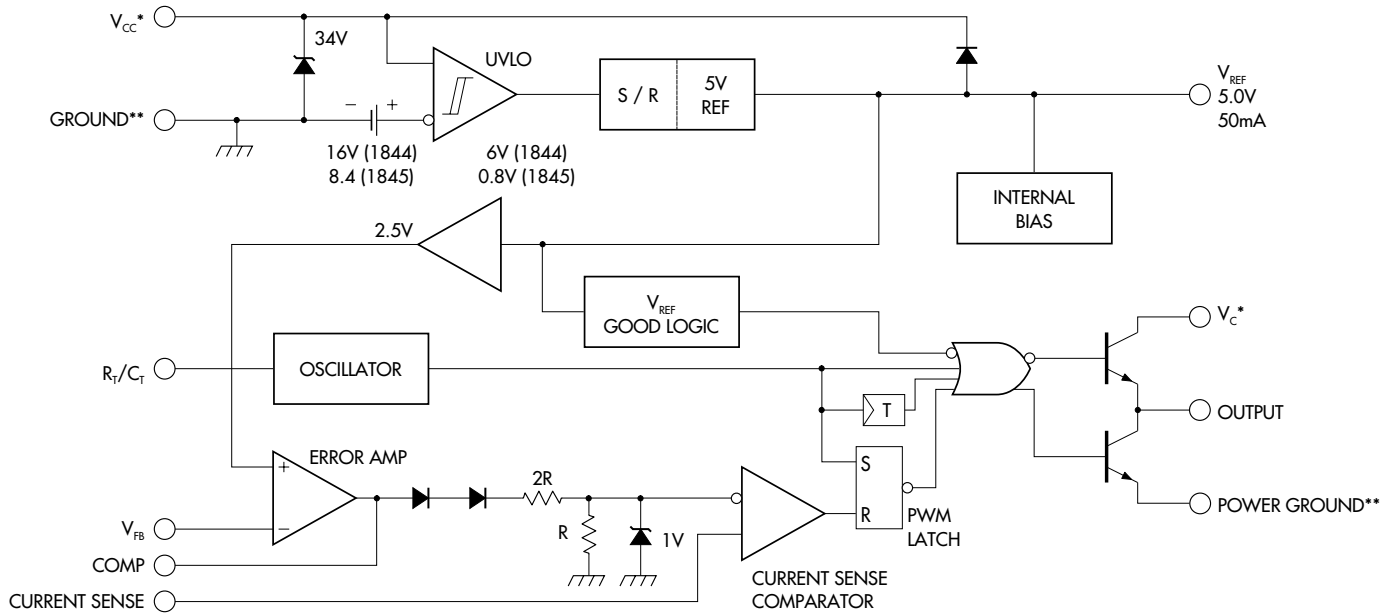

* - V_{CC} and V_c are internally connected for 8-pin packages.

** - POWER GROUND and GROUND are internally connected for 8-pin packages.

GRAPH / CURVE INDEX

Characteristic Curves

FIGURE

1. DROPOUT VOLTAGE vs. TEMPERATURE
2. OSCILLATOR TEMPERATURE STABILITY
3. CURRENT SENSE TO OUTPUT DELAY vs. TEMPERATURE
4. START-UP CURRENT vs. TEMPERATURE
5. REFERENCE VOLTAGE vs. TEMPERATURE
6. START-UP VOLTAGE THRESHOLD vs. TEMPERATURE
7. START-UP VOLTAGE THRESHOLD vs. TEMPERATURE
8. OSCILLATOR DISCHARGE CURRENT vs. TEMPERATURE
9. OUTPUT SATURATION VOLTAGE vs. OUTPUT CURRENT AND TEMPERATURE (SINK TRANSISTOR)
10. CURRENT SENSE THRESHOLD vs. ERROR AMPLIFIER OUTPUT
11. OUTPUT SATURATION VOLTAGE vs. OUTPUT CURRENT AND TEMPERATURE (SOURCE TRANSISTOR)

FIGURE INDEX

Application Information

FIGURE

12. OSCILLATOR TIMING CIRCUIT
13. OSCILLATOR FREQUENCY vs. R_T FOR VARIOUS C_T

Typical Applications Section

FIGURE

14. CURRENT SENSE SPIKE SUPPRESSION
15. MOSFET PARASITIC OSCILLATIONS
16. BIPOLAR TRANSISTOR DRIVE
17. ISOLATED MOSFET DRIVE
18. ADJUSTABLE BUFFERED REDUCTION OF CLAMP LEVEL WITH SOFTSTART
19. EXTERNAL DUTY CYCLE CLAMP AND MULTI-UNIT SYNCHRONIZATION
20. OSCILLATOR CONNECTION
21. ERROR AMPLIFIER CONNECTION

CURRENT-MODE PWM CONTROLLER

PRODUCTION DATA SHEET

CHARACTERISTIC CURVES

FIGURE 1. — DROPOUT VOLTAGE vs. TEMPERATURE

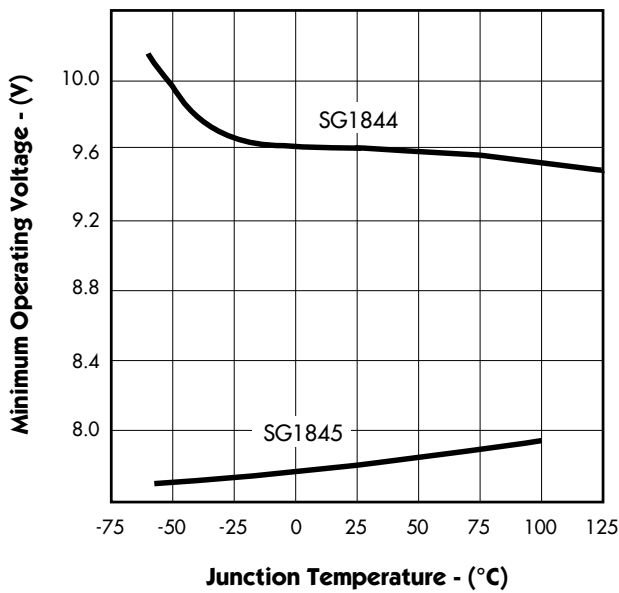

FIGURE 2. — OSCILLATOR TEMPERATURE STABILITY

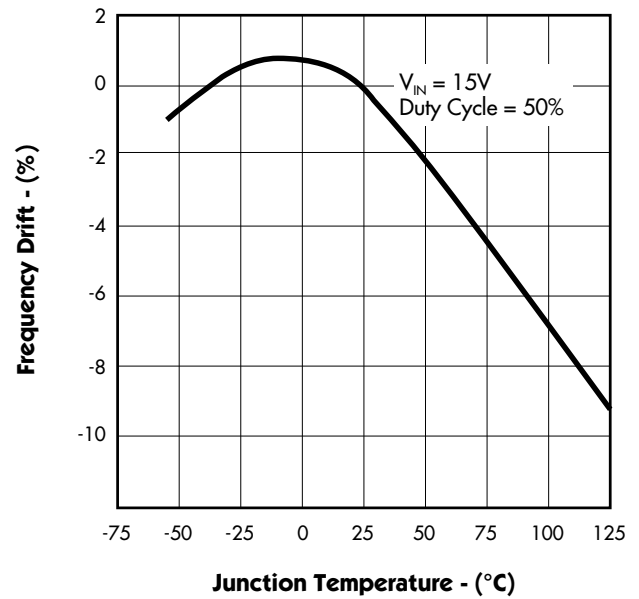

FIGURE 3. — CURRENT SENSE TO OUTPUT DELAY vs. TEMPERATURE

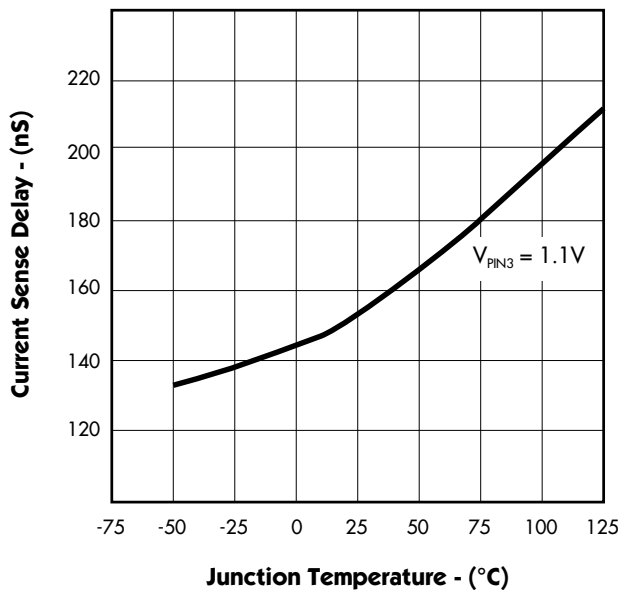
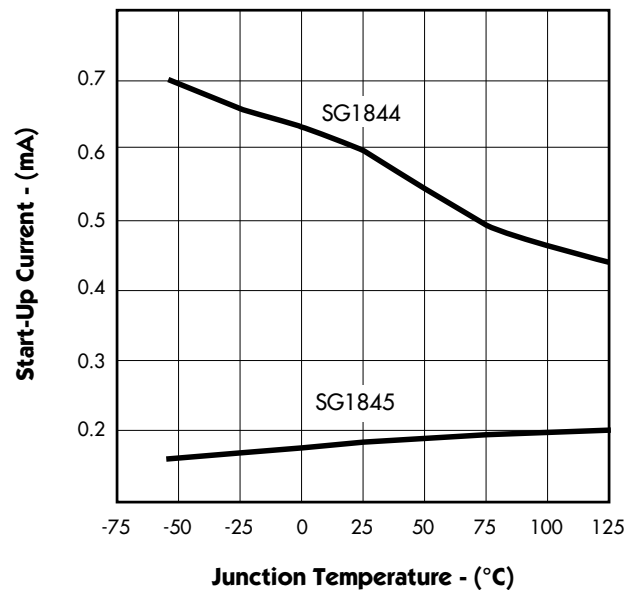

FIGURE 4. — START-UP CURRENT vs. TEMPERATURE



CHARACTERISTIC CURVES

FIGURE 5. — REFERENCE VOLTAGE vs. TEMPERATURE

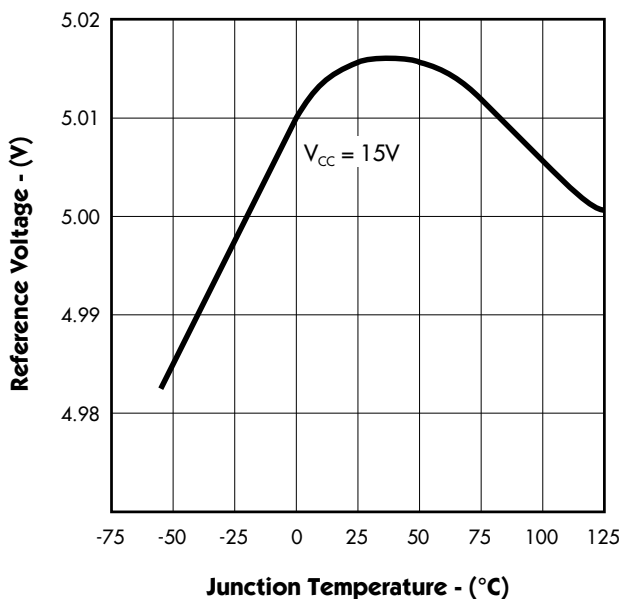

FIGURE 6. — START-UP VOLTAGE THRESHOLD vs. TEMPERATURE

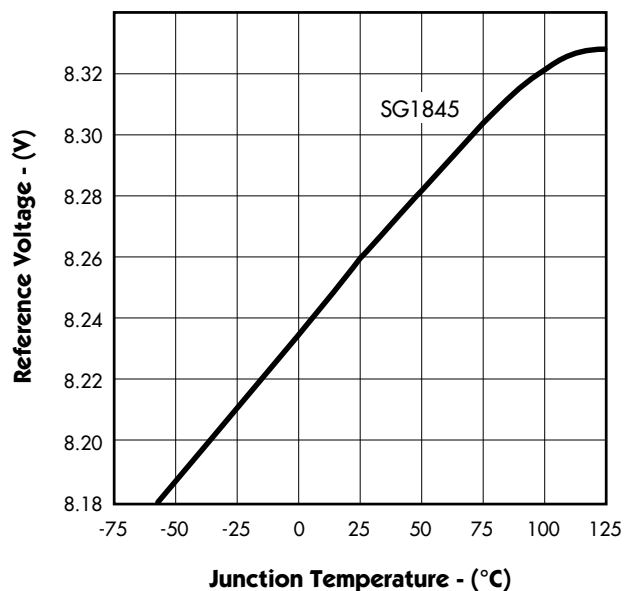

FIGURE 7. — START-UP VOLTAGE THRESHOLD vs. TEMPERATURE

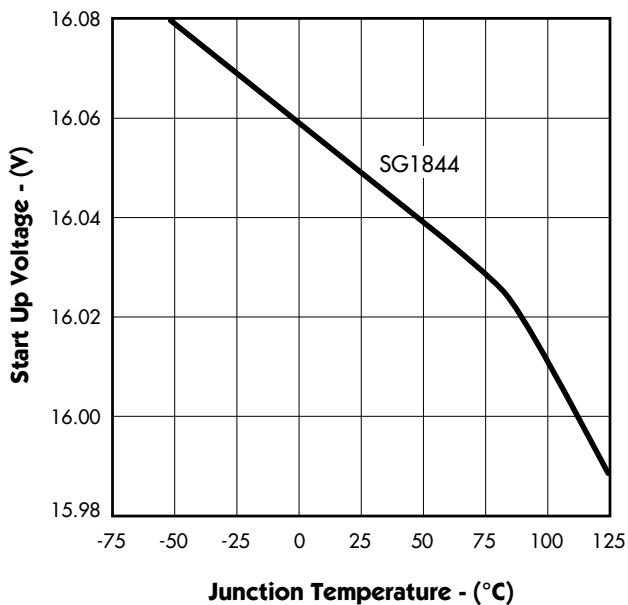
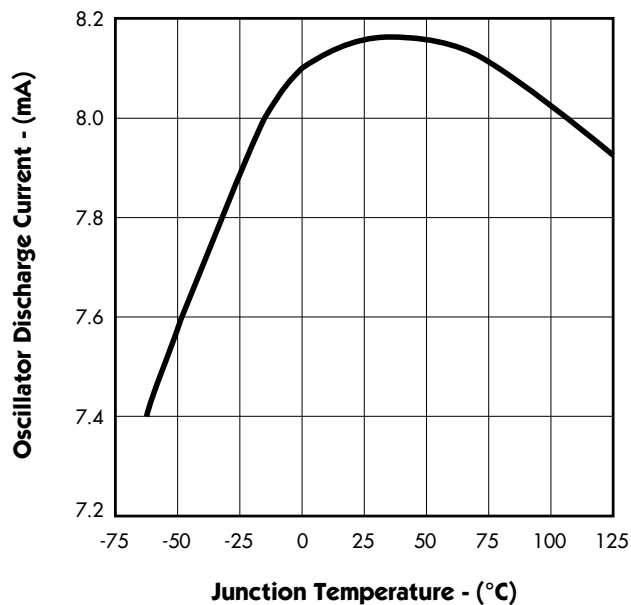

FIGURE 8. — OSCILLATOR DISCHARGE CURRENT vs. TEMPERATURE



CURRENT-MODE PWM CONTROLLER

PRODUCTION DATA SHEET

CHARACTERISTIC CURVES

FIGURE 9. — OUTPUT SATURATION VOLTAGE vs. OUTPUT CURRENT & TEMPERATURE

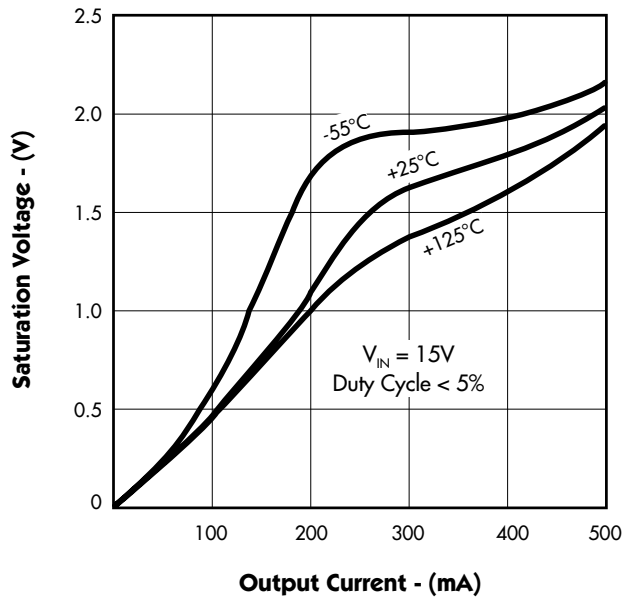

FIGURE 10. — CURRENT SENSE THRESHOLD vs. ERROR AMPLIFIER OUTPUT

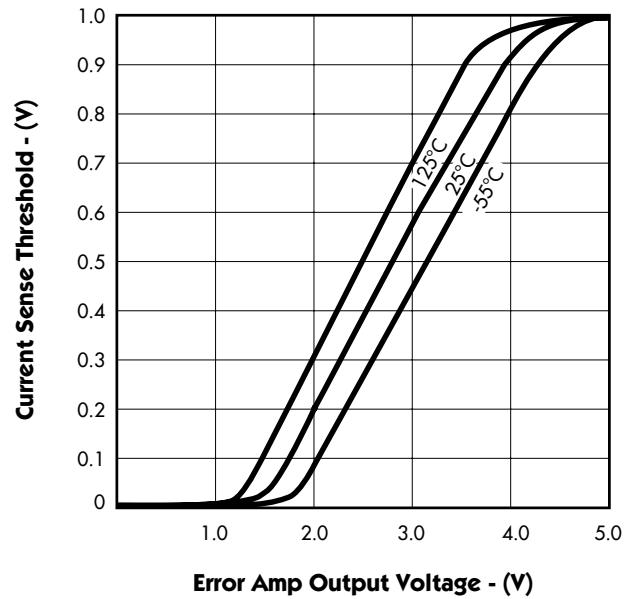
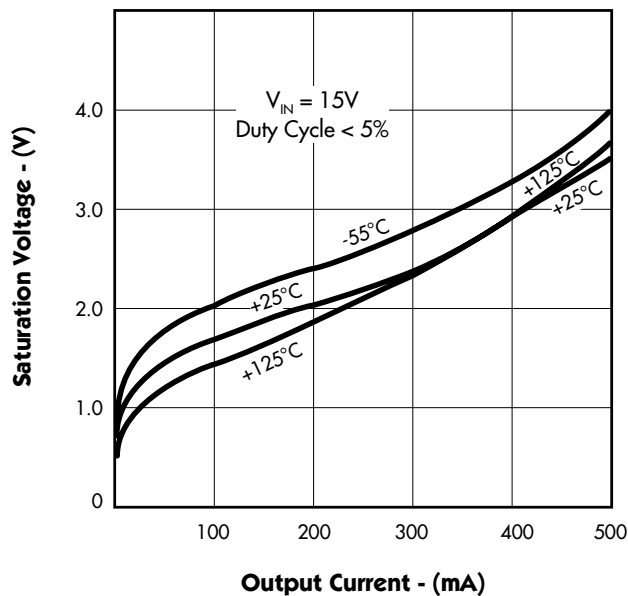

FIGURE 11. — OUTPUT SATURATION VOLTAGE vs. OUTPUT CURRENT & TEMPERATURE



APPLICATION INFORMATION

OSCILLATOR

The oscillator of the 1844/45 family of PWM's is programmed by the external timing components (R_T , C_T) as shown in Figure 13.

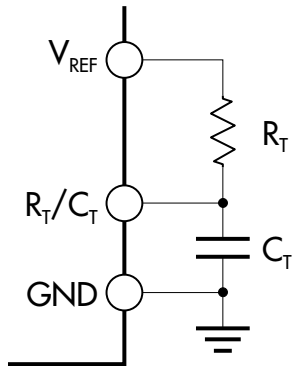

$$F \approx \frac{1.86}{R_T C_T} \text{ where } R_T \geq 5k\Omega$$

FIGURE 12 — OSCILLATOR TIMING CIRCUIT

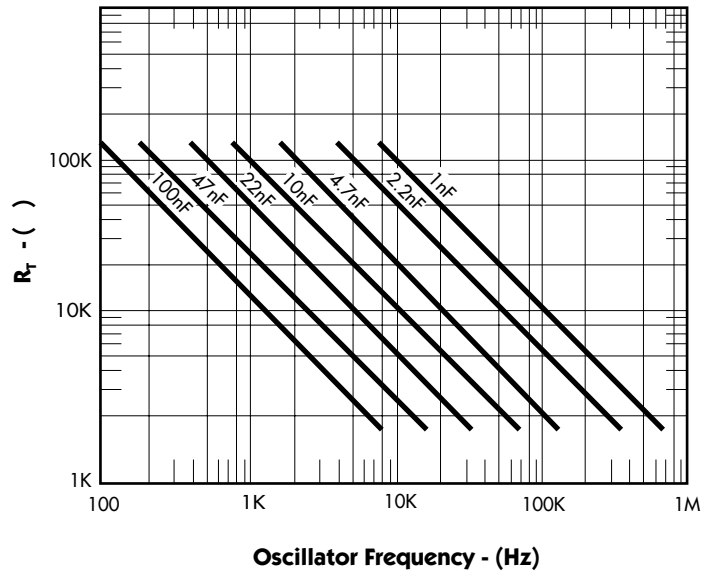

FIGURE 13 — OSCILLATOR FREQUENCY vs. R_T FOR VARIOUS C_T

CURRENT-MODE PWM CONTROLLER

PRODUCTION DATA SHEET

TYPICAL APPLICATION CIRCUITS

Pin numbers referenced are for 8-pin package and pin numbers in parenthesis are for 14-pin package.

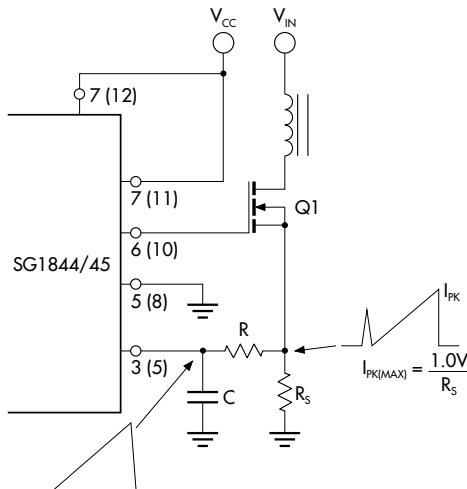

FIGURE 14. — CURRENT SENSE SPIKE SUPPRESSION

The RC low-pass filter will eliminate the leading edge current spike caused by parasitics of Power MOSFET.

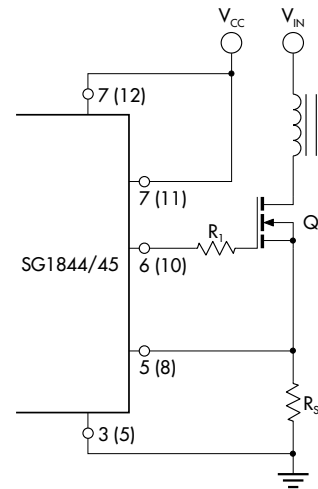

FIGURE 15. — MOSFET PARASITIC OSCILLATIONS

A resistor (R_1) in series with the MOSFET gate reduce overshoot and ringing caused by the MOSFET input capacitance and any inductance in series with the gate drive. (Note: It is very important to have a low inductance ground path to insure correct operation of the I.C. This can be done by making the ground paths as short and as wide as possible.)

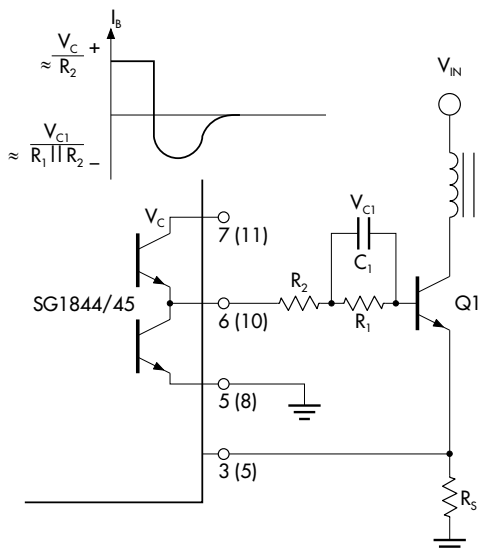
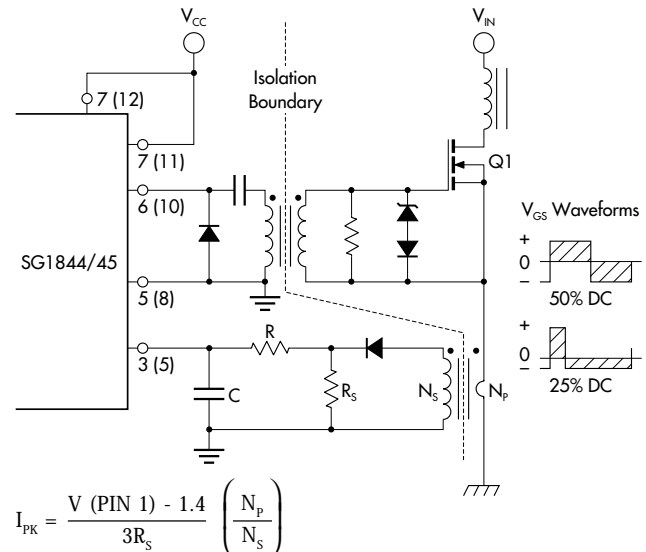

FIGURE 16. — BIPOLAR TRANSISTOR DRIVE

The 1844/45 output stage can provide negative base current to remove base charge of power transistor (Q_1) for faster turn off. This is accomplished by adding a capacitor (C_1) in parallel with a resistor (R_1). The resistor (R_1) is to limit the base current during turn on.



$$I_{PK} = \frac{V(\text{PIN } 1) - 1.4}{3R_s} \left(\frac{N_p}{N_s} \right)$$

FIGURE 17. — ISOLATED MOSFET DRIVE

Current transformers can be used where isolation is required between PWM and Primary ground. A drive transformer is then necessary to interface the PWM output with the MOSFET.

TYPICAL APPLICATION CIRCUITS (continued)

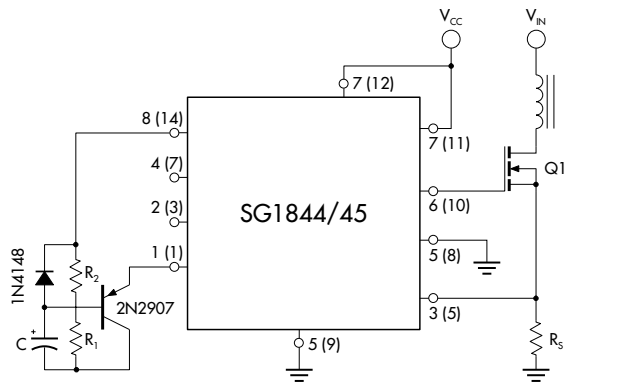

$$I_{PK} = \frac{V_1}{R_s} \quad \text{Where: } 0 \leq V_1 \leq 1.0V \quad t_{SOFTSTART} = -\ln 1 \left[-\frac{V_C}{V_2} \right] C \frac{R_1 R_2}{R_1 + R_2}$$

$$\text{and } V_1 = \frac{1.43 - 0.23 \frac{R_1}{R_2}}{1 + \frac{R_1}{R_2}} \quad \text{where: } V_2 = \frac{0.5}{1 + \frac{R_1}{R_2}}$$

FIGURE 18. — ADJUSTABLE BUFFERED REDUCTION OF CLAMP LEVEL WITH SOFTSTART

Softstart and adjustable peak current can be done with the external circuitry shown above.

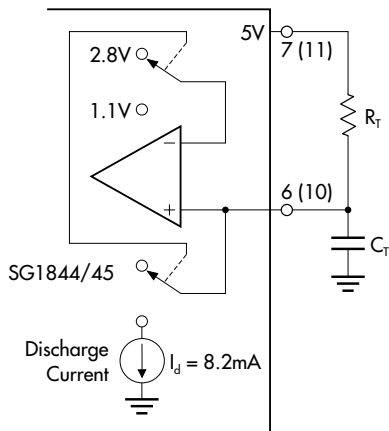
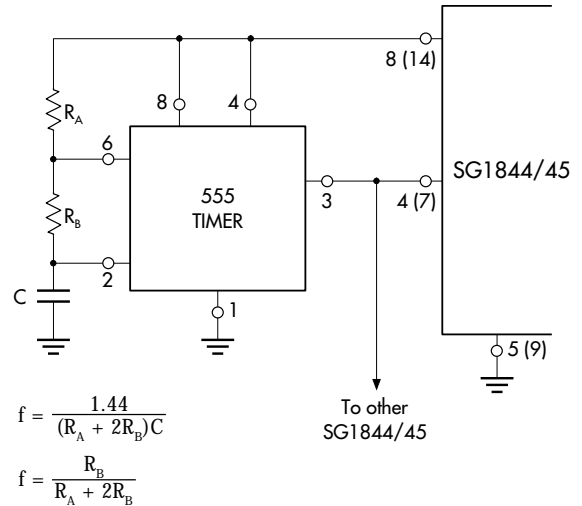

FIGURE 20. — OSCILLATOR CONNECTION

The oscillator is programmed by the values selected for the timing components R_T and C_T . Refer to application information for calculation of the component values.



$$f = \frac{1.44}{(R_A + 2R_B)C}$$

$$f = \frac{R_B}{R_A + 2R_B}$$

To other SG1844/45

FIGURE 19. — EXTERNAL DUTY CYCLE CLAMP AND MULTI-UNIT SYNCHRONIZATION

Precision duty cycle limiting for a duty cycle of <50%, as well as synchronizing several 1844/45's is possible with the above circuitry.

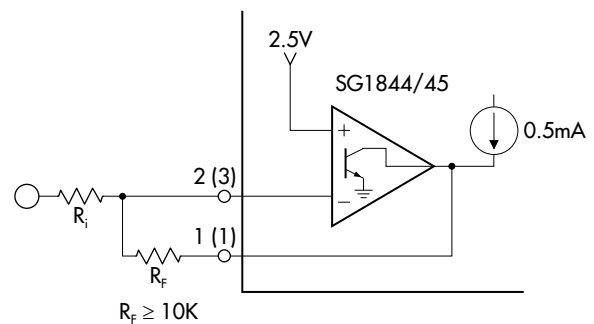

FIGURE 21. — ERROR AMPLIFIER CONNECTION

Error amplifier is capable of sourcing and sinking current up to 0.5mA.