

Dual, 12–Bit, Low Power Voltage Output D/A Converter

- Low Cost
- Two 12–Bit DAC's on a Single Chip
- Very Low Power — 16 mW (8mW/DAC)
- Double-Buffered Inputs
- $\pm 5V$ Supply Operation
- Voltage Outputs, $\pm 4.5V$ Range
- Midscale Preset, Zero Volts Out
- Guaranteed ± 0.5 LSB Max INL
- Guaranteed ± 0.75 LSB Max DNL
- 250kHz 4-Quadrant Multiplying Bandwidth
- Separate Reference Inputs
- 28–pin SOIC and Plastic DIP Packages
- Either 12 or 8 bit μ p bus

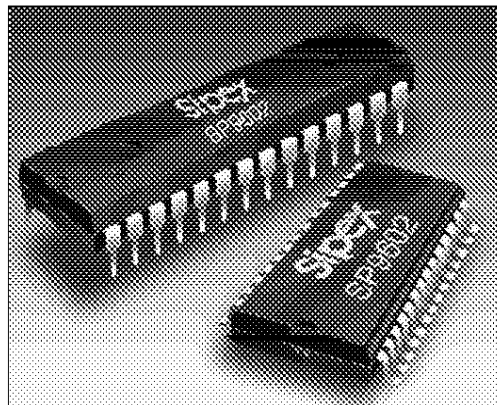

DESCRIPTION

The **SP9602** is a low power, dual 12–Bit Digital-to-Analog Converter. It features $\pm 4.5V$ output swings when using ± 5 volt supplies. The converter is double-buffered for easy microprocessor interface. Each 12–Bit DAC is independently addressable and both DACS may be simultaneously updated using a single transfer command. The output settling-time is specified at $30\mu s$. The **SP9602** is available in 28–pin SOIC and plastic DIP packages, specified over commercial temperature range.

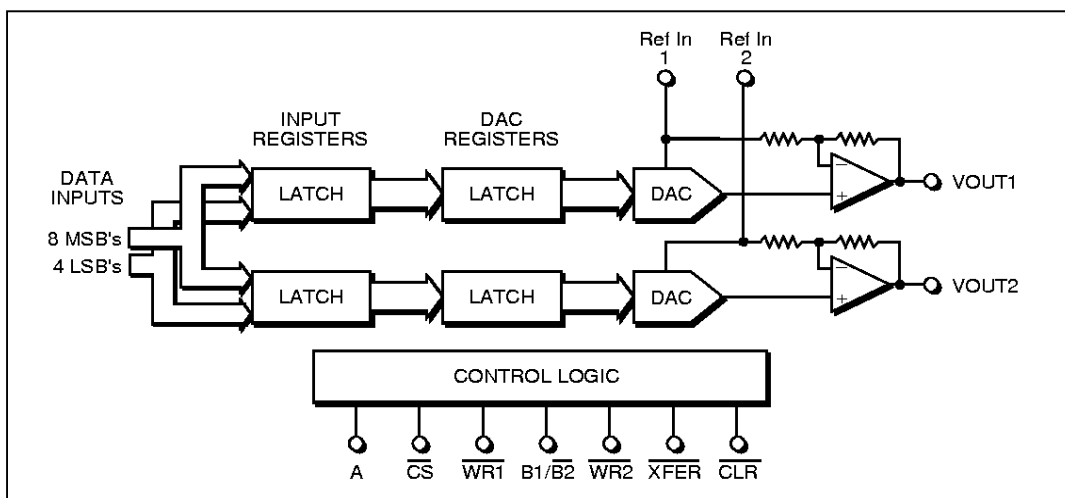

ABSOLUTE MAXIMUM RATINGS

These are stress ratings only and functional operation of the device at these or any other above those indicated in the operation sections of the specifications below is not implied. Exposure to absolute maximum rating conditions for extended periods of time may affect reliability.

$V_{DD} - GND$	-0.3V, +6.0V
$V_{SS} - GND$	+0.3V, -6.0V
$V_{DD} - V_{SS}$	-0.3V, +12.0V
V_{REF}	V_{SS}, V_{DD}
D_N	V_{SS}, V_{DD}
Power Dissipation	
Plastic DIP	375mW
(derate 7mW/°C above +70°C)	
Small Outline	375mW
(derate 7mW/°C above +70°C)	

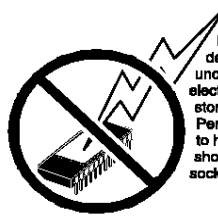

CAUTION:
ESD (ElectroStatic Discharge) sensitive device. Permanent damage may occur on unconnected devices subject to high energy electrostatic fields. Unused devices must be stored in conductive foam or shunts. Personnel should be properly grounded prior to handling this device. The protective foam should be discharged to the destination socket before devices are removed.

SPECIFICATIONS

(Typical at 25°C, $T_{MIN} \leq T_A \leq T_{MAX}$, $V_{DD} = +5V$, $V_{SS} = -5V$, $V_{REF} = +3V$; CMOS logic level digital inputs; specifications apply to all grades unless otherwise noted.)

PARAMETER	MIN.	TYP.	MAX.	UNITS	CONDITIONS
DIGITAL INPUTS					
Logic Levels					
V_{IH}	2.4			Volts	
V_{IL}			0.8	Volts	
4 Quad, Bipolar Coding		Offset Binary			
REFERENCE INPUT					
Voltage Range		± 3	± 4.5	Volts	Note 5
Input Resistance	6	8.8		k Ω	$D_N = 1,877$; code dependent
ANALOG OUTPUT					
Gain					
-K		± 0.5	± 2.0	LSB	$V_{REF} = \pm 3V$; Note 3
-J		± 1.0	± 4.0	LSB	$V_{REF} = \pm 3V$; Note 3
		± 1.0	± 5.0	LSB	$V_{REF} = \pm 4.5V$; Note 3
Initial Offset Bipolar		± 0.25	± 3.0	LSB	$D_N = 2,048$
Voltage Range Bipolar		± 3.0	± 4.5	Volts	
Output Current	± 5.0 ± 0.5			mA mA	$V_{REF} = \pm 3V$ $V_{REF} = \pm 4.5V$
STATIC PERFORMANCE					
Resolution	12			Bits	
Integral Linearity					
-K		± 0.25	± 0.5	LSB	$V_{REF} = \pm 3V$; Note 3
-J		± 0.5	± 1.0	LSB	$V_{REF} = \pm 3V$; Note 3
		± 0.5	± 3.0	LSB	$V_{REF} = \pm 4.5V$; Note 3
Differential Linearity					
-K		± 0.25	± 0.75	LSB	
-J		± 0.25	± 1.0	LSB	
Monotonicity		Guaranteed			
DYNAMIC PERFORMANCE					
Settling Time					
Small Signal		4		μs	to 0.024%
Full Scale		30		μs	to 0.024%
Slew Rate		0.3		V/ μs	
Multiplying Bandwidth		250		KHz	

SPECIFICATIONS (continued)

(Typical at 25°C, $T_{MIN} \leq T_A \leq T_{MAX}$; $V_{DD} = +5V$, $V_{SS} = -5V$, $V_{REF} = +3V$; CMOS logic level digital inputs; specifications apply to all grades unless otherwise noted.)

PARAMETER	MIN.	TYP.	MAX.	UNITS	CONDITIONS
STABILITY					
Gain		15		ppm/°C	t_{MIN} to t_{MAX}
Bipolar Zero		15		ppm/°C	t_{MIN} to t_{MAX}
SWITCHING CHARACTERISTICS					
t_{DS} Data Set Up Time	140	100		ns	to rising edge of WR1 Figure 4
t_{DN} Data Hold Time	0			ns	
t_{WR} Write Pulse Width	140	100		ns	
t_{XFER} Transfer Pulse Width	140			ns	
t_{WC} Total Write Command	280	200		ns	
POWER REQUIREMENTS					
V_{DD} -J, -K		1.6	2.5	mA	Note 5 +5V, $\pm 3\%$; Note 4, 5
V_{SS} -J, -K		1.6	2.5	mA	-5V, $\pm 3\%$; Note 4, 5
Power Dissipation		16		mW	
ENVIRONMENTAL AND MECHANICAL					
Operating Temperature -J, -K	0		+70	°C	
Storage Packages	-60		+150	°C	
-N	28-pin Plastic DIP				
-S	28-pin SOIC				

Notes:

1. Integral Linearity, for the SP9602, is measured as the arithmetic mean value of the magnitudes of the greatest positive deviation and the greatest negative deviation from the theoretical value for any given input condition.
2. Differential Linearity is the deviation of an output step from the theoretical value of 1 LSB for any two adjacent digital input codes.
3. $1 \text{ LSB} = 2 \cdot V_{REF} / 4,096$.
4. $V_{REF} = 0V$.
5. The following power up sequence is recommended to avoid latch up: Vss (-5V), VDD (+5V), REFIN.

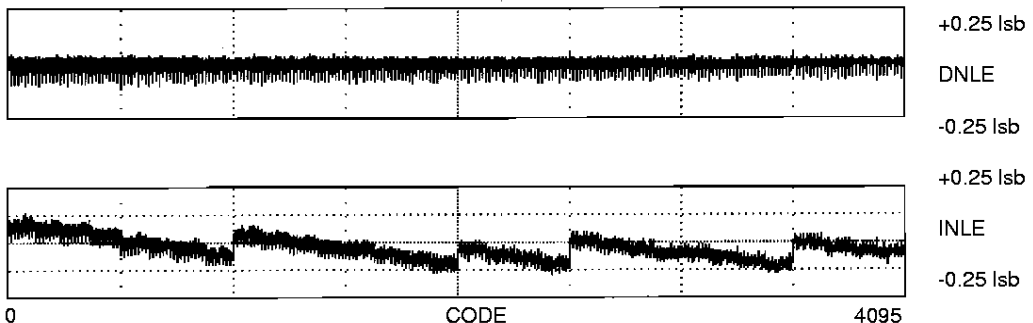

0 CODE 4095
INLE, DNLE Plots

PIN ASSIGNMENTS

Pin 1 — N.C. — No Connection.

Pin 2 — V_{OUT2} — Voltage Output from DAC2.

Pin 3 — V_{SS} — -5V Power Supply Input.

Pin 4 — V_{DD} — +5V Power Supply Input.

Pin 5 — \overline{CLR} — \overline{Clear} . Gated with $\overline{WR2}$ (pin 12). Active low. Clears both DAC outputs to 0V.

Pin 6 — REF IN 2 — Reference Input for DAC2.

Pin 7 — GND — Ground.

Pin 8 — $B1/\overline{B2}$ — Byte 1/ $\overline{Byte 2}$ — Selects Data Input Format. A logic “1” on pin 8 selects the 12-bit mode, and all 12 data bits are presented to the DAC(s) unchanged; a logic “0” selects the 8-bit mode, and the four LSBs are connected to the four MSBs, allowing an 8-bit MSB-justified interface.

Pin 9 — A — Address for DAC Selection — A logic “0” selects DAC 1; a logic “1” selects DAC 2.

Pin 10 — REF IN 1 — Reference Input for DAC1.

Pin 11 — \overline{XFER} — $\overline{Transfer}$. Gated with $\overline{WR2}$ (pin 12); loads all DAC registers simultaneously. Active low.

Pin 12 — $\overline{WR2}$ — $\overline{Write Input 2}$ — In conjunction with \overline{XFER} (pin 11), controls the transfer of data from the input registers to the DAC registers. In conjunction with \overline{CLR} (pin 5), the DAC registers are forced to 1000 0000 0000 and the DAC outputs will settle to OV. Active low.

PINOUT — 28-PIN SOIC & DIP

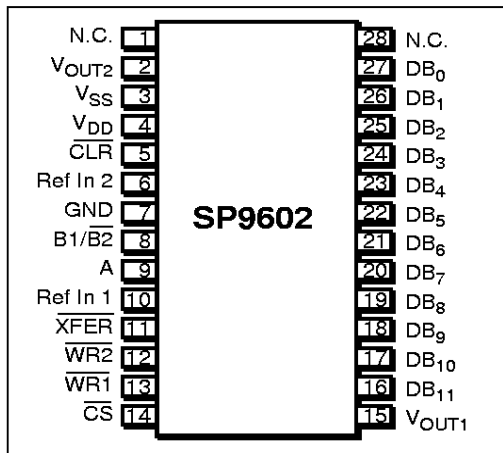

Pin 13 — $\overline{WR1}$ — $\overline{Write Input 1}$ — In conjunction with \overline{CS} (pin 14), enables input register selection, and controls the transfer of data from the input bus to the input registers. Active low.

Pin 14 — \overline{CS} — $\overline{Chip Select}$ — Enables writing data to input registers and/or transferring data from input bus to DAC registers.

Pin 15 — V_{OUT1} — Voltage Output from DAC1.

Pin 16 — DB_{11} — Data Bit 11; most significant bit.

Pin 17 — DB_{10} — Data Bit 10.

Pin 18 — DB_9 — Data Bit 9.

Pin 19 — DB_8 — Data Bit 8.

Pin 20 — DB_7 — Data Bit 7.

Pin 21 — DB_6 — Data Bit 6.

Pin 22 — DB_5 — Data Bit 5.

Pin 23 — DB_4 — Data Bit 4.

Pin 24 — DB_3 — Data Bit 3.

Pin 25 — DB_2 — Data Bit 2.

Pin 26 — DB_1 — Data Bit 1.

Pin 27 — DB_0 — Data Bit 0; LSB

Pin 28 — N.C. — No Connection.

FEATURES

The **SP9602** is a very low power, dual version of the popular SP9345, Quad 12-Bit Digital-to-Analog Converter. This Dual, Voltage Output, 12-Bit Digital-to-Analog Converter features $\pm 4.5V$ output swings when using ± 5 volt supplies. The input coding format used is standard offset binary. (Please refer to *Table 1* below.)

The converter utilizes double-buffering on each of the 12 parallel digital inputs, for easy microprocessor interface. Each 12-bit DAC is independently addressable and both DACs may be simultaneously updated using a single \overline{XFER} command. The output settling-time is specified at $30\mu s$ to full 12-bit accuracy when driving a $5K\Omega$, $50pF$ load combination. The **SP9602**, Dual 12-Bit Digital-to-Analog Converter is ideally suited for applications such as ATE, process controllers, robotics, and instrumentation. The **SP9602** is available in 28-pin plastic SOIC and plastic DIP packages, specified over the commercial ($0^{\circ}C$ to $+70^{\circ}C$) temperature range.

THEORY OF OPERATION

The **SP9602** consists of five main functional blocks — the input data multiplexer, the data registers, control logic, two 12-bit D/A converters, and two bipolar output voltage amplifiers. The input data multiplexer is designed to interface to either 12- or 8-bit microprocessor data busses. The input data format is controlled by the $B1/\overline{B2}$ signal — a logic “1” selects the 12-bit mode, while a logic “0” selects the 8-bit mode. In the 12-bit mode the data is transferred to the input registers without changes in its format. In the 8-

bit mode, the four least significant bits (LSBs) are connected to the four most significant bits (MSBs), allowing an 8-bit MSB-justified interface. All data inputs are enabled using the \overline{CS} signal in both modes. The digital inputs are designed to be both TTL and 5V CMOS compatible.

In order to reduce the DAC full scale output sensitivity to the large weighting of the MSB's found in conventional R-2R resistor ladders, the 3 MSB's are decoded into 8 equally weighted levels. This reduces the contribution of each bit by a factor of 4, thus, reducing the output sensitivity to mismatches in resistors and switches by the same amount. Linearity errors and stability are both improved for the same reasons.

Each D/A converter is separated from the data bus by two registers, each consisting of level-triggered latches, *Figure 1*. The first register (input register) is 12-bits wide. The input register is selected by the address input A_0 and A_1 and is enabled by the \overline{CS} and $\overline{WR1}$ signals. In the 8-bit mode, the enable signal to the 8 MSB's is disabled by a logic low on $B1/\overline{B2}$ to allow the 4 LSB's to be updated. The second register (DAC register), accepts the decoded 3 MSB's plus the 9 LSB's. The two DAC registers are updated simultaneously for both DAC's using the \overline{XFER} and $\overline{WR2}$ signals. Using the \overline{CLR} and $\overline{WR2}$ signals or the power-on-reset, (enabled when the power is switched on) the DAC registers are set to 1000 0000 0000 and the DAC outputs will settle to 0V.

Using the control logic inputs, the user has full control of address decoding, chip enable, data transfer and clearing of the DAC's. The control logic inputs are level triggered, and like the data inputs, are TTL and CMOS compatible. The truth table (*Table 2*) shows the appropriate functions associated with the states of the control logic inputs.

The DACs themselves are implemented with a precision thin-film resistor network and CMOS transmission gate switches. Each D/A converter is used to convert the 12-bit input from its DAC register to a precision voltage.

The bipolar voltage output of the **SP9602** is created on-chip from the DAC Voltage Output (V_{DAC}) by using an operational amplifier and two feedback resistors connected as shown in *Figure 2*. This configuration produces a $\pm 4.5V$ bipolar output range with standard offset binary coding (See *Table 1*).

INPUT		OUTPUT
MSB	LSB	
1111	1111 1111	$V_{REF} - 1 \text{ LSB}$
1111	1111 1110	$V_{REF} - 2 \text{ LSB}$
1000	0000 0001	$0 + 1 \text{ LSB}$
1000	0000 0000	0
0000	0000 0001	$-V_{REF} + 1 \text{ LSB}$
0000	0000 0000	$-V_{REF}$
1 LSB =		$\frac{2V_{REF}}{2^{12}}$

Table 1. Offset Binary Coding

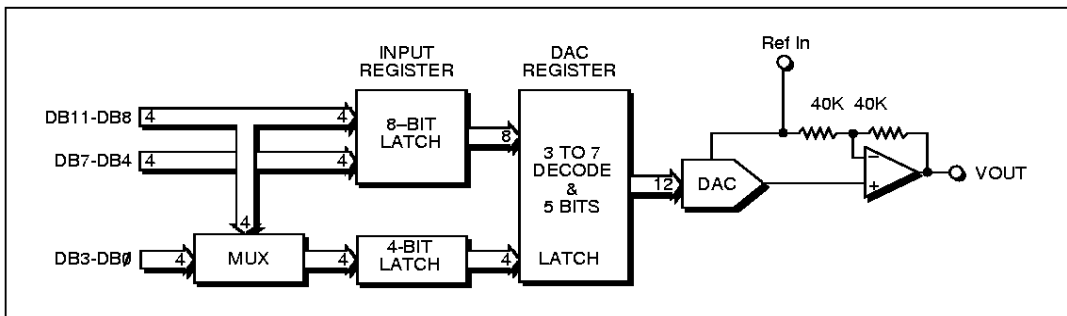

Figure 1. Detailed Block Diagram (only one DAC shown).

USING THE SP9602 WITH DOUBLE-BUFFERED INPUTS

Loading Data

To load a 12-bit word to the input register of each DAC, using a 12-bit data bus, the sequence is as follows:

- 1) Set $\overline{XFER}=1$, $B1/\overline{B2}=1$, $\overline{CLR}=1$, $\overline{WR1}=1$, $\overline{WR2}=1$, $\overline{CS}=1$.
- 2) Set A (the DAC address) to the desired DAC — $0 = DAC_1$; $1 = DAC_2$
- 3) Set D11 (MSB) through D0 (LSB) to the desired digital input code.
- 4) Load the word to the selected DAC by cycling $\overline{WR1}$ and \overline{CS} through the following sequence: “1” — “0” — “1”
- 5) Repeat sequence for each input register.

To load a 12-bit word to the input register of each DAC, using an 8-bit data bus, the sequence is as follows:

- 1) Set $\overline{XFER}=1$, $B1/\overline{B2}=1$, $\overline{CLR}=1$, $\overline{WR1}=1$, $\overline{WR2}=1$, $\overline{CS}=1$.
- 2) Set D11 through D4 to the 8 MSB's of the desired digital input code.
- 3) Load the 8 MSB's of the digital word to the selected input register by cycling $\overline{WR1}$ and \overline{CS} through the “1” — “0” — “1” sequence.
- 4) Reset $B1/\overline{B2}$ from “1” — “0”
- 5) Set D11 (MSB) through D8 to the 4 LSB's of the digital input code.
- 6) Load the 4 LSB's by cycling $\overline{WR1}$ and \overline{CS} through the “1” — “0” — “1” sequence.
- 7) Repeat sequence for each input register.

TRANSFERRING DATA

To transfer the 12-bit words in the two input registers to the two DAC registers:

- 1) Set $\overline{CLR}=1$, $\overline{CS}=1$, $\overline{WR1}=1$.

- 2) Cycle $\overline{WR2}$ and \overline{XFER} through the “1” — “0” — “1” sequence.

To set the outputs of the two DAC's to 0V, cycle $\overline{WR2}$ and \overline{CLR} through the “1” — “0” — “1” sequence, while keeping $\overline{XFER} = 1$.

One Latch, or No Latches

The latches that form the registers can be used in a “semi-” transparent mode, and a “fully-” transparent mode. In order to use the SP9602 in either mode the user must be interfaced to a 12-bit bus only ($B1=1$).

The semi-transparent mode is set up such that the first set of latches is transparent and the second set is used to latch the incoming data. Data is latched into the second set rather than the first set, in order to minimize glitch energy induced from the data formatting. In this mode, $\overline{WR1}$ and \overline{CS} are tied low, and $\overline{WR2}$ and \overline{XFER} are used to strobe the data to the addressed DAC. Each DAC is addressed using the address line A. After the appropriate DAC has been selected and the data is settled at the digital inputs, bringing $\overline{WR2}$ and \overline{XFER} low will transfer the data to the addressed DAC. The user should be sure to bring \overline{XFER} and $\overline{WR2}$ high again so that the next selected DAC will not be overwritten by the last digital code. This mode of operation may be useful in applications where preloading of the input registers is not necessary; *Figure 3, top.*

A fully transparent mode is realized by tying $\overline{WR1}$, \overline{CS} , $\overline{WR2}$, and \overline{XFER} all low. In this mode, anything that is written on the 12-bit data bus will be passed directly to the selected DAC. Since both latches are not being used, the previous digital word will be overwritten by the new data as soon as the address changes. This may be useful should the user want to

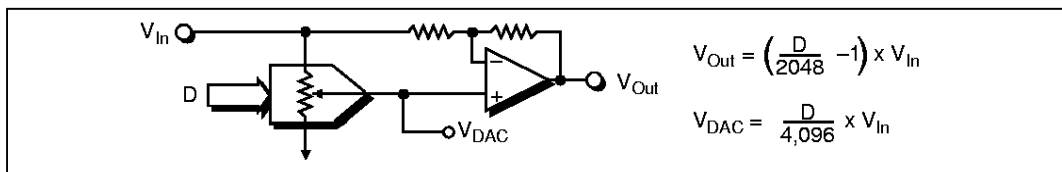

Figure 2. Transfer Function

calibrate a circuit, by taking full scale or zero scale readings for both DAC's; Figure 3, bottom.

Zeroing DAC Outputs

While keeping XFER pin high, the DAC outputs can be set to zero volts two different ways. The first involves the CLR and WR2 pins. In normal operation, the CLR pin is tied high, thus, disabling the clear function. By cycling WR2 and CLR through "1"—"0"—"1" sequence, a digital code of 1000 0000 0000 is written to both DAC registers, producing a halfscale output or zero volts. The second utilizes the built in power-on-reset. Using this feature, the SP9602 can be configured such that during power-up, the second register will be digitally "zeroed", producing a zero volt output at each of the DAC outputs. This is

achieved by powering the unit up with XFER in a high state. Thus, with no external circuitry, the SP9602 can be powered up with the analog outputs at a known, zero volt output level.

Temporarily Forcing Both DAC Outputs to 0V

Set WR1=1, CS=1, WR2=0, XFER=0. The DAC registers can be temporarily forced to 1000 0000 0000 by bringing the CLR pin low. This will cause the DAC outputs to 0V, while the CLR pin remains low. When the CLR pin is brought back high, the digital code at the DAC registers will again appear at the DAC's digital inputs, and the analog outputs will return to their previous values.

A	CS	WR1	B1/B2	WR2	XFER	CLR	FUNCTION
0			1	1	X	X	Address DAC 1 and load input register
0			0	1	X	X	Address DAC 1 and load 4 LSBs
1			1	1	X	X	Address DAC 2 and load input register
1			0	1	X	X	Address DAC 2 and load 4 LSBs
X	**	**	X			1	Transfer data from input registers to DAC registers
X	1	1	X	0	0		Temporarily force both DAC output voltages to 0V, while CLR is low.
X	X	X	X		1		Sets all DAC output voltages to 0V
X	1	X	X	X	X	X	Invalid state with any other control line active
X	X	1	X	X	X	X	Invalid state with any other control line active

X = Don't care; ** = Don't care; however, CS and WR1 = 1 will inhibit changes to the input registers.

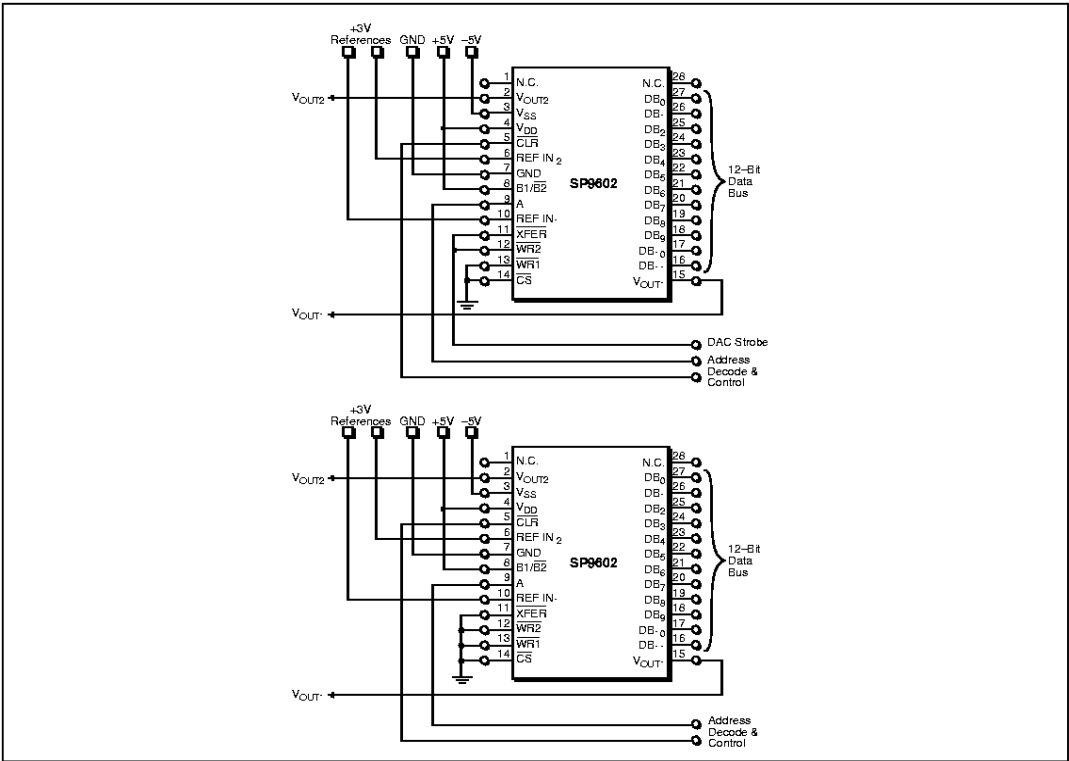

Figure 3. Latch Control Options — (Top) Semi-Transparent Latch Mode; (Bottom) Fully-Transparent Latch Mode

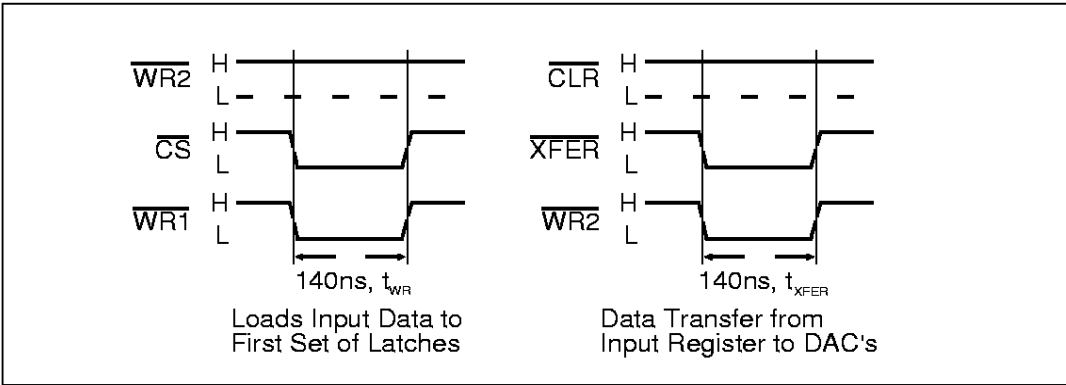
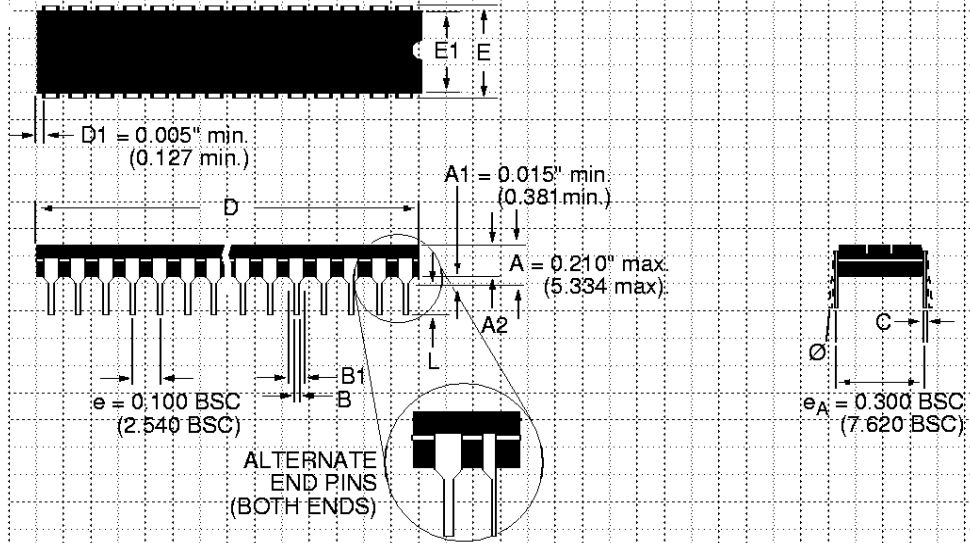

Figure 4. Timing

PACKAGE: PLASTIC DUAL-IN-LINE (NARROW)



DIMENSIONS (Inches) Minimum/Maximum (mm)	24-PIN	28-PIN
A2	0.115/0.195 (2.921/4.953)	0.115/0.195 (2.921/4.953)
B	0.014/0.023 (0.356/0.584)	0.014/0.022 (0.356/0.559)
B1	0.045/0.070 (1.143/1.778)	0.045/0.070 (1.143/1.778)
C	0.008/0.014 (0.203/0.356)	0.008/0.014 (0.203/0.356)
D	1.155/1.280 (29.33/32.51)	1.385/1.454 (35.17/36.90)
E	0.300/0.325 (7.620/8.255)	0.300/0.325 (7.620/8.255)
E1	0.240/0.280 (6.096/7.112)	0.240/0.280 (6.096/7.112)
L	0.115/0.150 (2.921/3.810)	0.115/0.150 (2.921/3.810)
\emptyset	0°/15° (0°/15°)	0°/15° (0°/15°)

**PACKAGE: PLASTIC
SMALL OUTLINE (SOIC)**

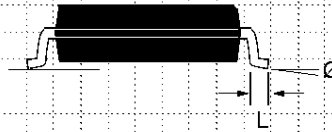
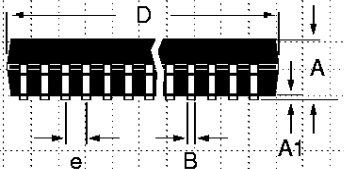
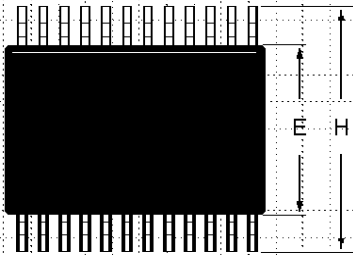

DIMENSIONS (Inches) Minimum/Maximum (mm)	14-PIN	16-PIN	18-PIN	20-PIN	24-PIN	28-PIN
A	0.090/0.104 (2.29/2.649)	0.090/0.104 (2.29/2.649)	0.090/0.104 (2.29/2.649)	0.090/0.104 (2.29/2.649)	0.090/0.104 (2.29/2.649)	0.090/0.104 (2.29/2.649)
A1	0.004/0.012 (0.102/0.300)	0.004/0.012 (0.102/0.300)	0.004/0.012 (0.102/0.300)	0.004/0.012 (0.102/0.300)	0.004/0.012 (0.102/0.300)	0.004/0.012 (0.102/0.300)
B	0.013/0.020 (0.330/0.508)	0.013/0.020 (0.330/0.508)	0.013/0.020 (0.330/0.508)	0.013/0.020 (0.330/0.508)	0.013/0.020 (0.330/0.508)	0.013/0.020 (0.330/0.508)
D	0.348/0.363 (8.83/9.22)	0.398/0.413 (10.10/10.49)	0.447/0.463 (11.35/11.74)	0.496/0.512 (12.60/13.00)	0.599/0.614 (15.20/15.59)	0.697/0.713 (17.70/18.09)
E	0.291/0.299 (7.402/7.600)	0.291/0.299 (7.402/7.600)	0.291/0.299 (7.402/7.600)	0.291/0.299 (7.402/7.600)	0.291/0.299 (7.402/7.600)	0.291/0.299 (7.402/7.600)
e	0.050 BSC (1.270 BSC)	0.050 BSC (1.270 BSC)	0.050 BSC (1.270 BSC)	0.050 BSC (1.270 BSC)	0.050 BSC (1.270 BSC)	0.050 BSC (1.270 BSC)
H	0.394/0.419 (10.00/10.64)	0.394/0.419 (10.00/10.64)	0.394/0.419 (10.00/10.64)	0.394/0.419 (10.00/10.64)	0.394/0.419 (10.00/10.64)	0.394/0.419 (10.00/10.64)
L	0.016/0.050 (0.406/1.270)	0.016/0.050 (0.406/1.270)	0.016/0.050 (0.406/1.270)	0.016/0.050 (0.406/1.270)	0.016/0.050 (0.406/1.270)	0.016/0.050 (0.406/1.270)
∅	0°/8° (0°/8°)	0°/8° (0°/8°)	0°/8° (0°/8°)	0°/8° (0°/8°)	0°/8° (0°/8°)	0°/8° (0°/8°)

ORDERING INFORMATION

Model	Temperature Range	Package
Monolithic, 12-Bit Dual DAC, Voltage Output:		
SP9602JN	0°C to +70°C	28-pin, 0.3" Plastic DIP
SP9602KN	0°C to +70°C	28-pin, 0.3" Plastic DIP
SP9602JS	0°C to +70°C	28-pin, 0.3" SOIC
SP9602KS	0°C to +70°C	28-pin, 0.3" SOIC

Please consult the factory for pricing and availability on a Tape-On-Reel option.



SIGNAL PROCESSING EXCELLENCE

Sipex Corporation

Headquarters and Sales Office
 22 Linnell Circle
 Billerica, MA 01821
 TEL: (978) 667-8700
 FAX: (978) 670-9001
 e-mail: sales@sipex.com

Sales Office
 233 South Hillview Drive
 Milpitas, CA 95035
 TEL: (978) 934-7500
 FAX: (978) 935-7600

European Sales Offices:

ENGLAND:
 Sipex Corporation
 2 Linden House
 Turk Street
 Alton Hampshire GU34 1AN
 England
 TEL: 44-1420-549527
 FAX: 44-1420-542700
 e-mail: mikeb@sipex.co.uk

GERMANY:
 Sipex GmbH
 Gautinger Strasse 10
 82319 Starnberg
 TEL: 49.81.51.89810
 FAX: 49.81.51.29598
 e-mail: sipex-starnberg@t-online.de

Far East:

JAPAN:
 Nippon Sipex Corporation
 Yahagi No. 2 Building
 3-5-3 Uchikanda, Chiyoda-ku
 Tokyo 101
 TEL: 81.3.3256.0577
 FAX: 81.3.3256.0621

Sipex Corporation reserves the right to make changes to any products described herein. Sipex does not assume any liability arising out of the application or use of any product or circuit described hereing; neither does it convey any license under its patent rights nor the rights of others.