

Features

- ✧ For surface mounted applications in order to optimize board space
- ✧ Low profile package
- ✧ Built-in strain relief
- ✧ Glass passivated junction
- ✧ Low inductance
- ✧ Typical IR less than 0.5uA above 11V
- ✧ High temperature soldering guaranteed: 260°C / 10 seconds at terminals
- ✧ Plastic package has Underwriters Laboratory Flammability Classification 94V-0
- ✧ Green compound with suffix "G" on packing code & prefix "G" on datecode
- ✧ ESD Rating of Class 3B(HBM) per JEDEC.

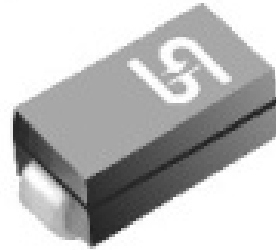

Mechanical Data

- ✧ Case: Molded plastic over passivated junction
- ✧ Terminals: Pure tin plated, lead free, solderable per MIL-STD-750, method 2026
- ✧ Polarity: Color Band denotes positive end (cathode)
- ✧ Standard packaging: 12mm tape (EIA-481)
- ✧ Weight: 0.064 gram

Ordering Information (example)

Part No.	Package	Packing	Packing code	Green Compound Packing code
1SMA5926	SMA	1.8K / 7" REEL	R3	R3G

Maximum Ratings and Electrical Characteristics

Rating at 25 °C ambient temperature unless otherwise specified.

Type Number	Symbol	Value	Unit
DC Power Dissipation at TL=75°C, measure at Zero Lead Length (Note 1) Derate above 75°C	P _D	1.5 20	Watts mW/°C
Peak Forward Surge Current, 8.3ms Single Half Sine-wave Superimposed on Rated Load (JEDEC method)	I _{FSM}	10	Amps
Operating and Storage Temperature Range	T _J , T _{STG}	-55 to +150	°C

Note 1: Mounted on Cu-Pad size 5mm x 5mm x 1.6mm on PCB

ELECTRICAL CHARACTERISTICS (TA=25°C unless otherwise noted)

Device (Note 1)	Device Marking Code	Nominal Zener Voltage			Test Current	Zener Impedance			Leakage Current		Maximum DC Zener Current
		Vz@Iz			IzT	ZzT@IzT	ZzK@IzK		IR@VR		IzM
		V			mA	Ω	Ω	mA	uA	V	mA(DC)
		Min.	Nom. (Notes 2)	Max.							
1SMA5926	926A	10.45	11	11.55	34.1	5.5	550	0.25	0.5	8.4	136
1SMA5927	927A	11.40	12	12.60	31.2	6.5	550	0.25	0.5	9.1	125
1SMA5928	928A	12.35	13	13.65	28.8	7.0	550	0.25	0.5	9.9	115
1SMA5929	929A	14.25	15	15.75	25.0	9.0	600	0.25	0.5	11.4	100
1SMA5930	930A	15.20	16	16.80	23.4	10.0	600	0.25	0.5	12.2	94
1SMA5931	931A	17.10	18	18.90	20.8	12.0	650	0.25	0.5	13.7	83
1SMA5932	932A	19.00	20	21.00	18.7	14.0	650	0.25	0.5	15.2	75
1SMA5933	933A	20.90	22	23.10	17.0	17.5	650	0.25	0.5	16.7	68
1SMA5934	934A	22.80	24	25.20	15.6	19.0	700	0.25	0.5	18.2	63
1SMA5935	935A	25.65	27	28.35	13.9	23.0	700	0.25	0.5	20.6	56
1SMA5936	936A	28.50	30	31.50	12.5	26.0	750	0.25	0.5	22.8	50
1SMA5937	937A	31.35	33	34.65	11.4	33.0	800	0.25	0.5	25.1	45
1SMA5938	938A	34.20	36	37.80	10.4	38.0	850	0.25	0.5	27.4	42
1SMA5939	939A	37.05	39	40.95	9.6	45.0	900	0.25	0.5	29.7	38
1SMA5940	940A	40.85	43	45.15	8.7	53.0	950	0.25	0.5	32.7	35
1SMA5941	941A	44.65	47	49.35	8.0	67.0	1000	0.25	0.5	35.8	32
1SMA5942	942A	48.45	51	53.55	7.3	70.0	1100	0.25	0.5	38.8	29
1SMA5943	943A	53.20	56	58.80	6.7	86.0	1300	0.25	0.5	42.6	27
1SMA5944	944A	58.90	62	65.10	6.0	100.0	1500	0.25	0.5	47.1	24
1SMA5945	945A	64.60	68	71.40	5.5	120.0	1700	0.25	0.5	51.7	22
1SMA5946	946A	71.25	75	78.75	5.0	140.0	2000	0.25	0.5	56.0	20
1SMA5947	947A	77.90	82	86.10	4.6	160.0	2500	0.25	0.5	62.2	18
1SMA5948	948A	86.45	91	95.55	4.1	200.0	3000	0.25	0.5	69.2	16
1SMA5949	949A	95.00	100	105.00	3.7	250.0	3100	0.25	0.5	76.0	15
1SMA5950	950A	104.50	110	115.50	3.4	300.0	4000	0.25	0.5	83.6	13
1SMA5951	951A	114.00	120	126.00	3.1	360.0	4500	0.25	0.5	91.2	12
1SMA5952	952A	123.50	130	136.50	2.9	450.0	5000	0.25	0.5	98.8	11
1SMA5953	953A	142.50	150	157.50	2.5	600.0	6000	0.25	0.5	114.0	10
1SMA5954	954A	152.00	160	168.00	2.3	700.0	6500	0.25	0.5	121.6	9
1SMA5955	955A	171.00	180	189.00	2.1	900.0	7000	0.25	0.5	136.8	8
1SMA5956	956A	190.00	200	210.00	1.9	1200.0	8000	0.25	0.5	152.0	7

Notes:

1. Tolerance and Voltage Regulation Designation. The type number listed indicates a tolerance of ±5%
2. Vz limits are to be guaranteed at thermal equilibrium

RATINGS AND CHARACTERISTIC CURVES (1SMA5926 THRU 1SMA5956)

FIG. 1 STEADY STATE POWER DERATING

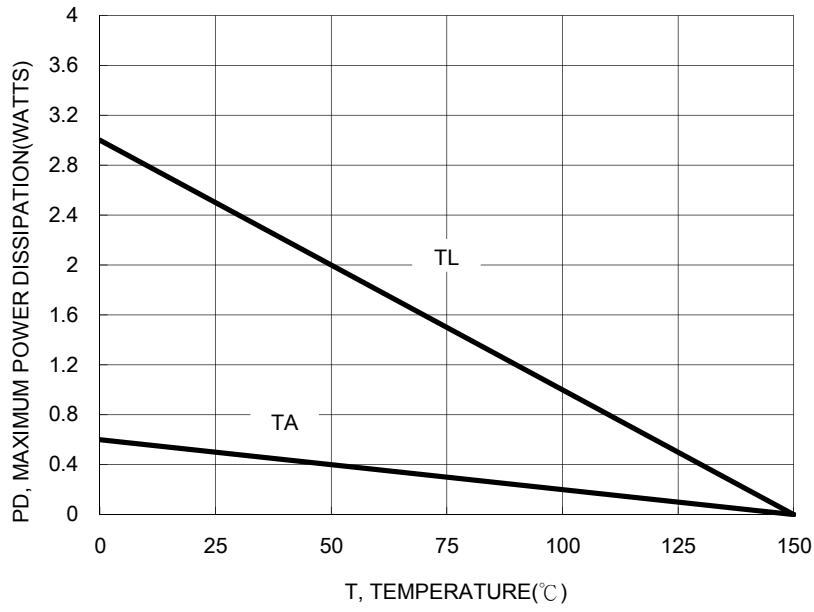

FIG. 2 $V_z = 12$ THRU 68 VOLTS

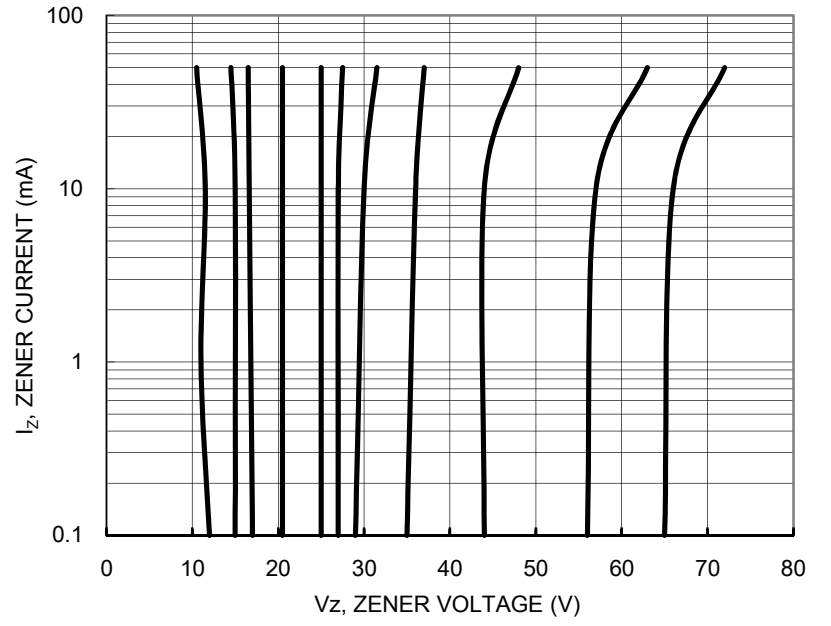

FIG. 3 ZENER VOLTAGE 12 TO 68 VOLTS

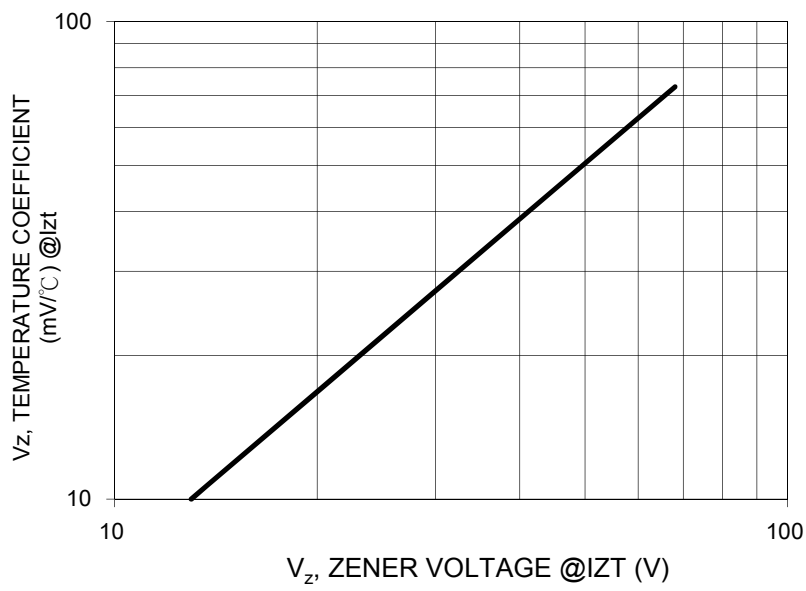
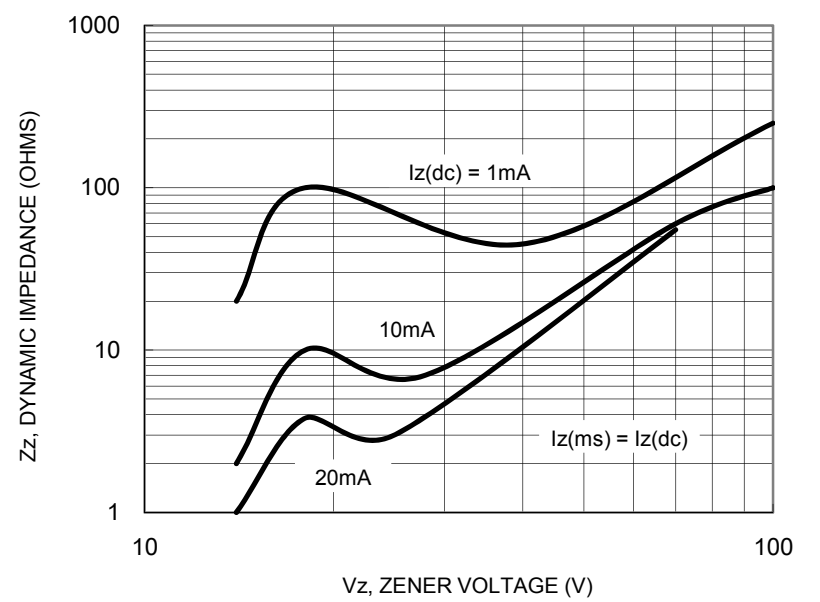

FIG. 4 EFFECT OF ZENER VOLTAGE



RATINGS AND CHARACTERISTIC CURVES (1SMA5926 THRU 1SMA5956)

FIG.5 CAPACITANCE CURVE

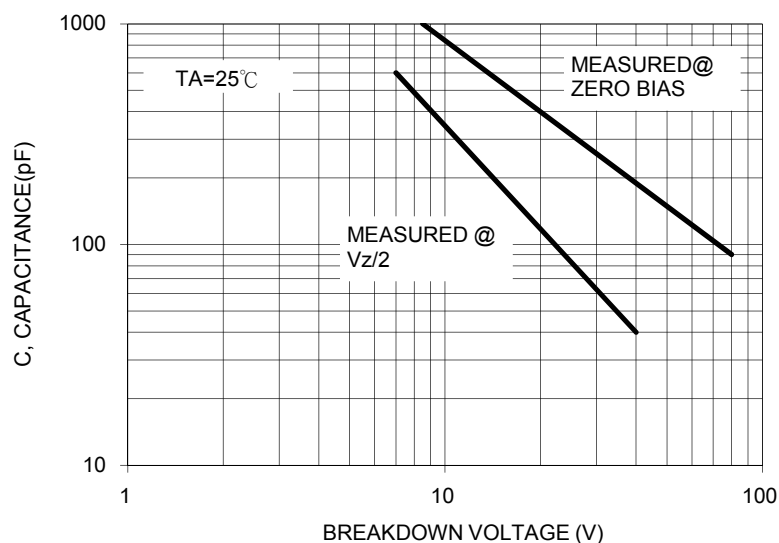

FIG. 6 TYPICAL PULSE RATING CURVE

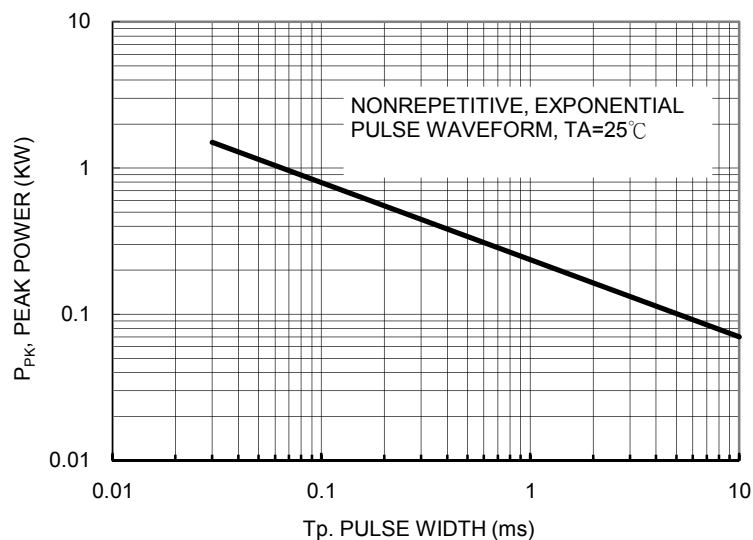

FIG. 7 PULSE WAVEFORM

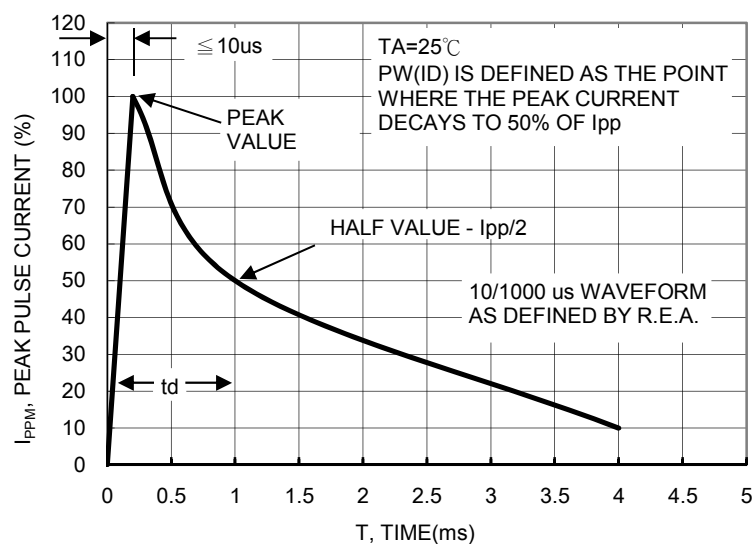
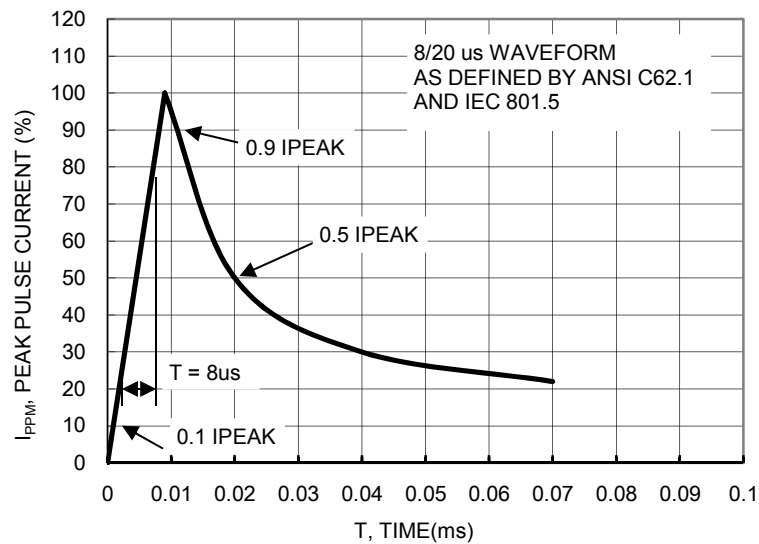

FIG. 8 PULSE WAVEFORM



Ordering information

Part No.	Package	Packing	Packing code	Green Compound Packing code
1SMA59xx (Note)	SMA	1.8K / 7" REEL	R3	R3G
	SMA	7.5K / 13" REEL	R2	R2G
	SMA	7.5K / 13" REEL	M2	M2G
	Folded SMA	1.8K / 7" REEL	F3	F3G
	Folded SMA	7.5K / 13" REEL	F2	F2G
	Folded SMA	7.5K / 13" REEL	F4	F4G
	C SMA	1.8K / 7" REEL	E3	E3G
	C SMA	7.5K / 13" REEL	E2	E2G
	C SMA	7.5K / 13" REEL	E4	E4G

Note: "x" is Device Code from "26" thru "56".

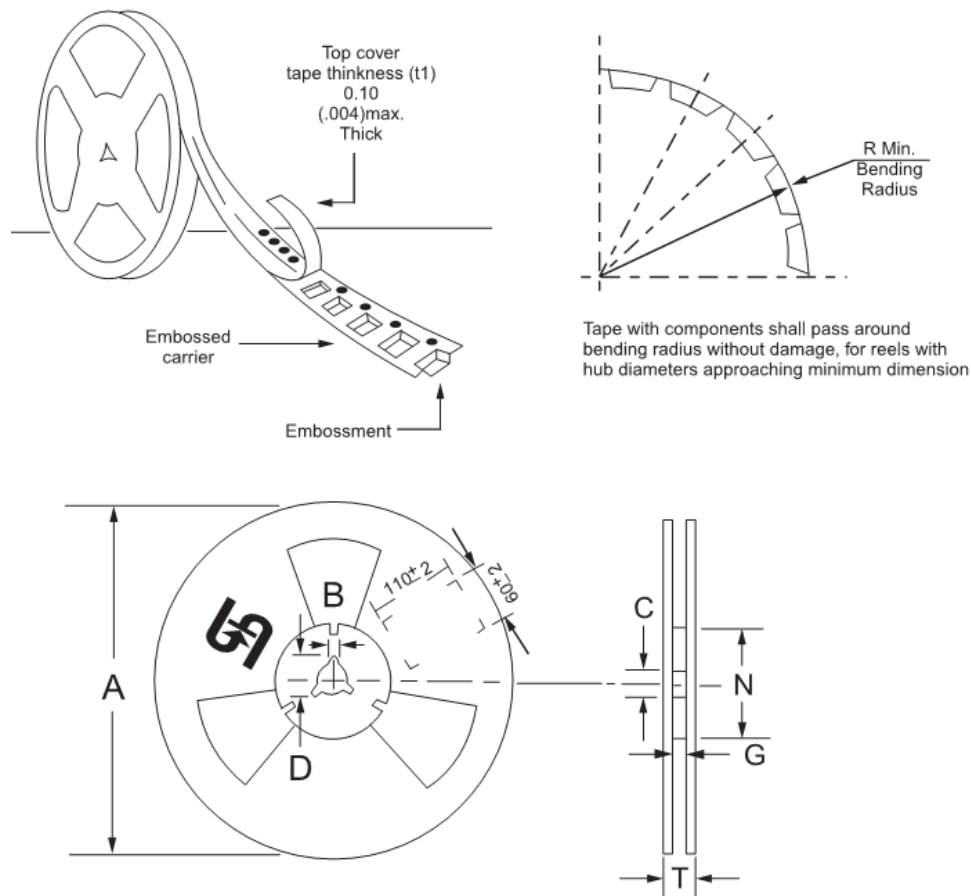
Tape & Reel specification

Reel Size	Tape Size	A	B	C	D	N	G	T
		±2.0	±0.4	+0.5;-0.2	min	±1.0	+0.8;-0	max
7"	12mm	178	1.9	13	21	62	12.2	14.6
Reel Size	Tape Size	A	B	C	D	N	G	T
		max	±0.5	±0.5	min	±0.5	+2.0;-0	max
13"	12mm	330	2	13	20.2	75	12.4	18.4

Unit (mm)

Suggested PAD Layout

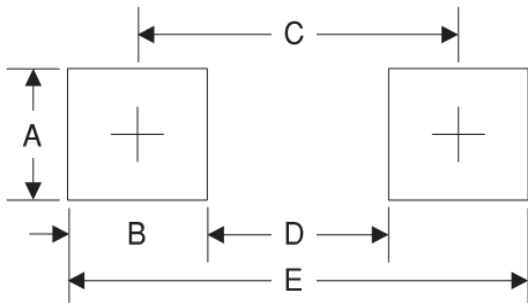

Symbol	Unit(mm)
A	1.78
B	1.51
C	3.92
D	2.41
E	4.43

Package Outline Dimensions

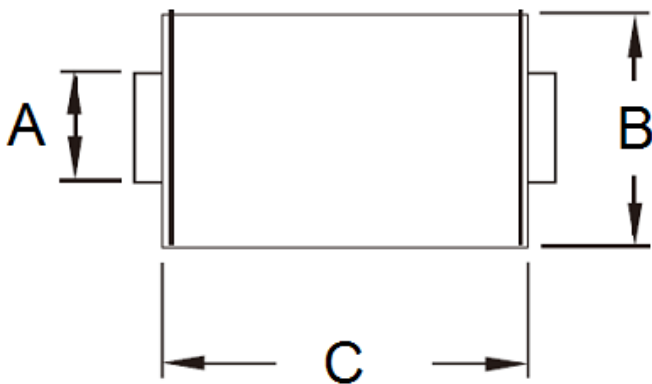

DIM.	Unit(mm)		Unit(inch)	
	Min	Max	Min	Max
A	1.27	1.58	0.050	0.062
B	2.29	2.83	0.090	0.111
C	4.06	4.60	0.160	0.181
D	1.99	2.50	0.078	0.098
E	0.90	1.41	0.035	0.056
F	0.15	0.31	0.006	0.012
G	0.10	0.20	0.004	0.008
H	4.95	5.33	0.195	0.210

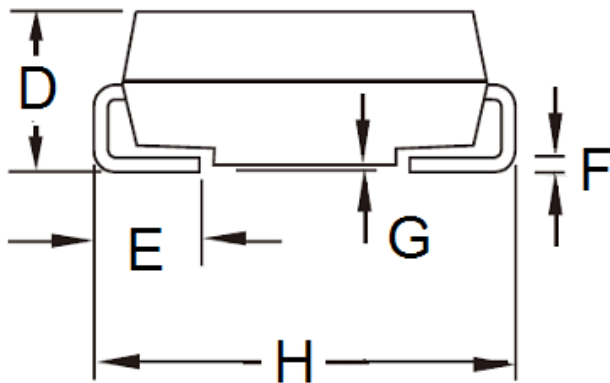

Marking Diagram

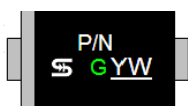

P/N = Specific Device Code
 G = Green Compound
 YW = Date Code