

LM725 Operational Amplifier

General Description

The LM725/LM725A/LM725C are operational amplifiers featuring superior performance in applications where low noise, low drift, and accurate closed-loop gain are required. With high common mode rejection and offset null capability, it is especially suited for low level instrumentation applications over a wide supply voltage range.

The LM725A has tightened electrical performance with higher input accuracy and like the LM725, is guaranteed over a -55°C to $+125^{\circ}\text{C}$ temperature range. The LM725C has slightly relaxed specifications and has its performance guaranteed over a 0°C to 70°C temperature range.

Features

- High open loop gain 3,000,000
- Low input voltage drift $0.6 \mu\text{V}/^{\circ}\text{C}$
- High common mode rejection 120 dB
- Low input noise current $0.15 \text{ pA}/\sqrt{\text{Hz}}$
- Low input offset current 2 nA
- High input voltage range $\pm 14\text{V}$
- Wide power supply range $\pm 3\text{V}$ to $\pm 22\text{V}$
- Offset null capability
- Output short circuit protection

Connection Diagrams

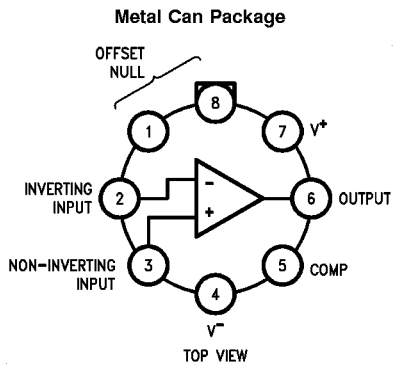

Order Number LM725H/883, LM725CH
or LM725AH/883
See NS Package Number H08C

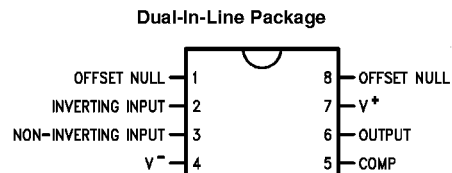

Order Number LM725CN
See NS Package Number N08E

Absolute Maximum Ratings (Note 1)

If Military/Aerospace specified devices are required, please contact the National Semiconductor Sales Office/Distributors for availability and specifications.

Supply Voltage	±22V
Internal Power Dissipation (Note 2)	500 mW
Differential Input Voltage	±5V
Input Voltage (Note 3)	±22V
Storage Temperature Range	-65°C to +150°C

Lead Temperature (Soldering, 10 Sec.)	260°C
Maximum Junction Temperature	150°C
Operating Temperature Range	$T_{A(MIN)}$ to $T_{A(MAX)}$
LM725	-55°C to +125°C
LM725A	-55°C to +125°C
LM725C	0°C to +70°C

Electrical Characteristics (Note 4)

Parameter	Conditions	LM725A			LM725			LM725C			Units
		Min	Typ	Max	Min	Typ	Max	Min	Typ	Max	
Input Offset Voltage (Without External Trim)	$T_A = 25^\circ\text{C}$, $R_S \leq 10\text{ k}\Omega$			0.5	0.5	1.0			0.5	2.5	mV
Input Offset Current	$T_A = 25^\circ\text{C}$		2.0	5.0	2.0	20		2.0	35		nA
Input Bias Current	$T_A = 25^\circ\text{C}$		42	80	42	100		42	125		nA
Input Noise Voltage	$T_A = 25^\circ\text{C}$										
	$f_o = 10\text{ Hz}$		15		15			15			nV/ $\sqrt{\text{Hz}}$
	$f_o = 100\text{ Hz}$		9.0		9.0			9.0			nV/ $\sqrt{\text{Hz}}$
	$f_o = 1\text{ kHz}$		8.0		8.0			8.0			nV/ $\sqrt{\text{Hz}}$
Input Noise Current	$T_A = 25^\circ\text{C}$										
	$f_o = 10\text{ Hz}$		1.0		1.0			1.0			pA/ $\sqrt{\text{Hz}}$
	$f_o = 100\text{ Hz}$		0.3		0.3			0.3			pA/ $\sqrt{\text{Hz}}$
	$f_o = 1\text{ kHz}$		0.15		0.15			0.15			pA/ $\sqrt{\text{Hz}}$
Input Resistance	$T_A = 25^\circ\text{C}$		1.5		1.5			1.5			M Ω
Input Voltage Range	$T_A = 25^\circ\text{C}$	±13.5	±14		±13.5	±14		±13.5	±14		V
Large Signal Voltage Gain	$T_A = 25^\circ\text{C}$, $R_L \geq 2\text{ k}\Omega$, $V_{OUT} = \pm 10\text{V}$	1000	3000		1000	3000		250	3000		V/mV
Common-Mode Rejection Ratio	$T_A = 25^\circ\text{C}$, $R_S \leq 10\text{ k}\Omega$	120			110	120		94	120		dB
Power Supply Rejection Ratio	$T_A = 25^\circ\text{C}$, $R_S \leq 10\text{ k}\Omega$		2.0	5.0		2.0	10		2.0	35	$\mu\text{V/V}$
Output Voltage Swing	$T_A = 25^\circ\text{C}$, $R_L \geq 10\text{ k}\Omega$	±12.5	±13.5		±12	±13.5		±12	±13.5		V
	$R_L \geq 2\text{ k}\Omega$	±12.0	±13.5		±10	±13.5		±10	±13.5		V
Power Consumption	$T_A = 25^\circ\text{C}$		80	105		80	105		80	150	mW
Input Offset Voltage (Without External Trim)	$R_S \leq 10\text{ k}\Omega$			0.7		1.5			3.5		mV
Average Input Offset Voltage Drift (Without External Trim)	$R_S = 50\Omega$			2.0		2.0	5.0		2.0		$\mu\text{V}/^\circ\text{C}$
Average Input Offset Voltage Drift (With External Trim)	$R_S = 50\Omega$		0.6	1.0		0.6			0.6		$\mu\text{V}/^\circ\text{C}$
Input Offset Current	$T_A = T_{MAX}$		1.2	4.0		1.2	20		1.2	35	nA
	$T_A = T_{MIN}$		7.5	18.0		7.5	40		4.0	50	nA
Average Input Offset Current Drift			35	90		35	150		10		pA/ $^\circ\text{C}$
Input Bias Current	$T_A = T_{MAX}$		20	70		20	100			125	nA
	$T_A = T_{MIN}$		80	180		80	200			250	nA

Electrical Characteristics (Note 4) (Continued)

Parameter	Conditions	LM725A			LM725			LM725C			Units
		Min	Typ	Max	Min	Typ	Max	Min	Typ	Max	
Large Signal Voltage Gain	$R_L \geq 2 \text{ k}\Omega$ $T_A = T_{MAX}$ $R_L \geq 2 \text{ k}\Omega$	1,000,000			1,000,000			125,000			V/V
	$T_A = T_{MIN}$	500,000			250,000			125,000			V/V
Common-Mode Rejection Ratio	$R_S \leq 10 \text{ k}\Omega$	110			100			115			dB
Power Supply Rejection Ratio	$R_S \leq 10 \text{ k}\Omega$	8.0			20			20			$\mu\text{V/V}$
Output Voltage Swing	$R_L \geq 2 \text{ k}\Omega$	± 12			± 10			± 10			V

Note 1: "Absolute Maximum Ratings" indicate limits beyond which damage to the device may occur. Operating Ratings indicate conditions for which the device is functional, but do not guarantee specific performance limits.

Note 2: Derate at 150°C/W for operation at ambient temperatures above 75°C.

Note 3: For supply voltages less than $\pm 22\text{V}$, the absolute maximum input voltage is equal to the supply voltage.

Note 4: These specifications apply for $V_S = \pm 15\text{V}$ unless otherwise specified.

Note 5: For Military electrical specifications RETS725AX are available for LM725AH and RETS725X are available for LM725H.

Schematic Diagram

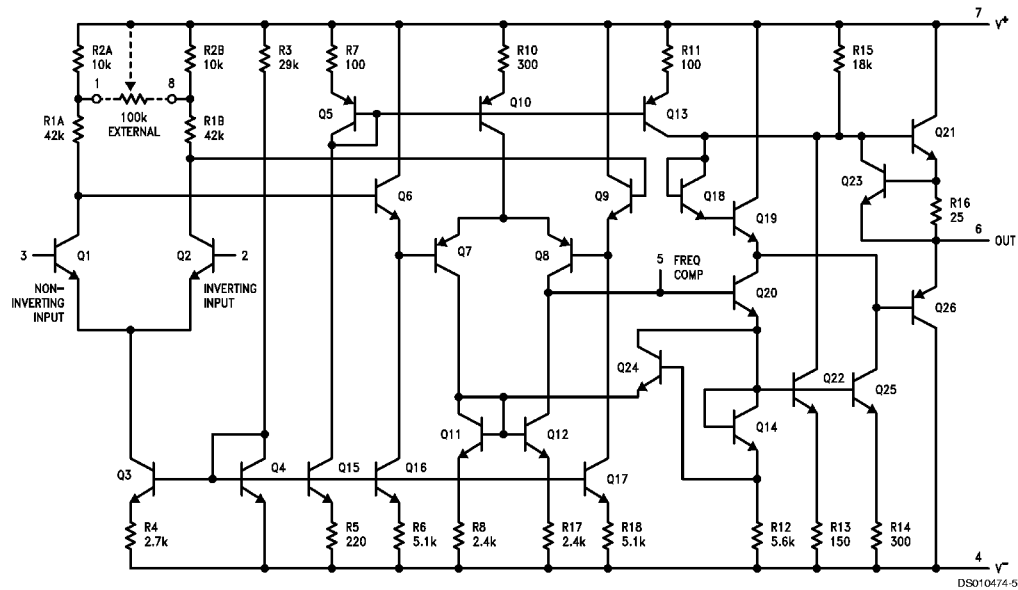

Typical Performance Characteristics

Voltage Gain vs Temperature for Supply Voltages

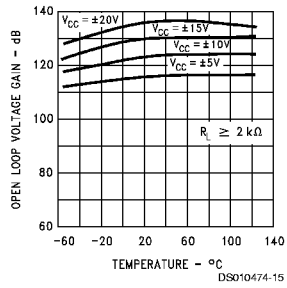

Change in Trimmed Input Offset Voltage vs Temperature

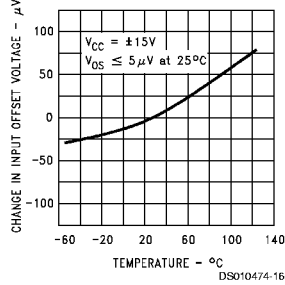

Untrimmed Input Offset Voltage vs Temperature

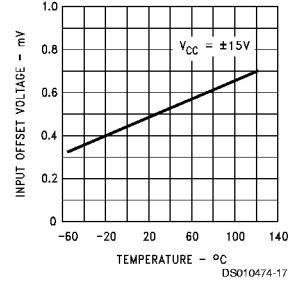

Input Offset Current vs Temperature

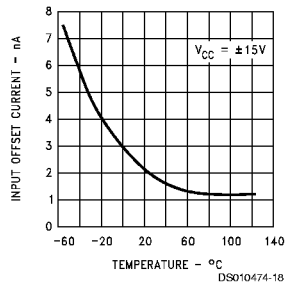

Input Bias Current vs Temperature

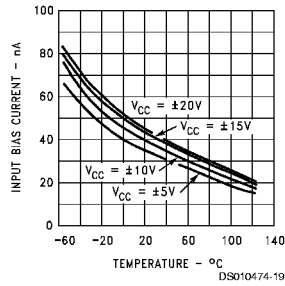

Stabilization Time of Input Offset Voltage from Power Turn-On

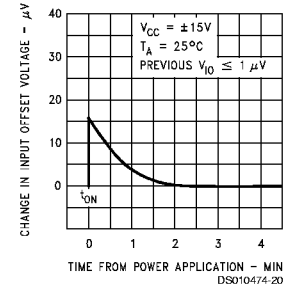

Change in Input Offset Voltage Due to Thermal Shock vs Time

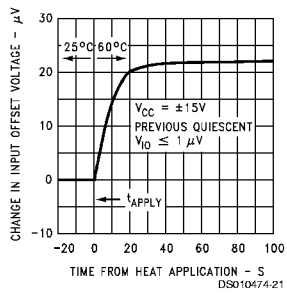

Input Noise Voltage vs Frequency

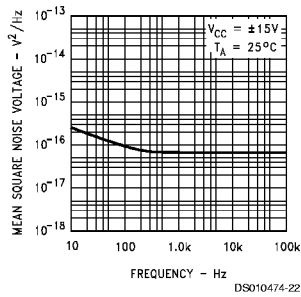

Input Noise Current vs Frequency

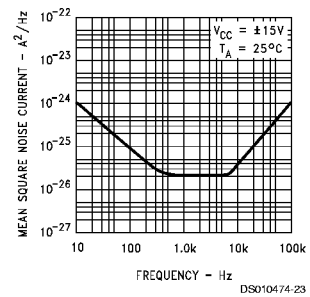

Typical Performance Characteristics (Continued)

Power Consumption vs Temperature

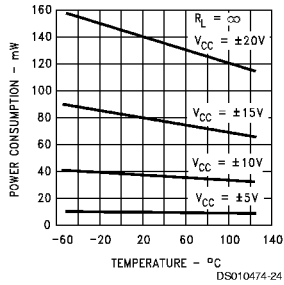

Open Loop Frequency Response for Values of Compensation (Note 6)

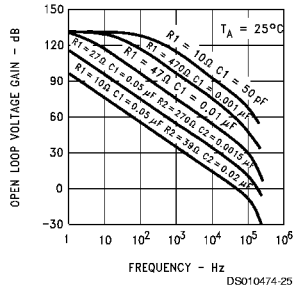

Values for Suggested Compensation Networks vs Various Close Loop Voltage Gains

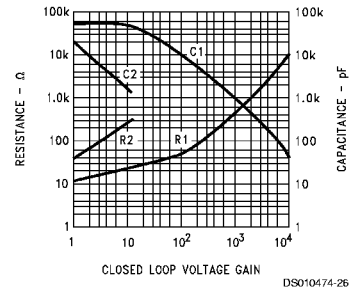

Frequency Response for Various Close Loop Gain (Note 6)

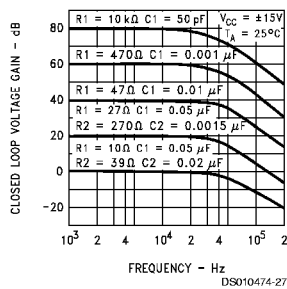

Output Voltage Swing vs Frequency (Note 6)

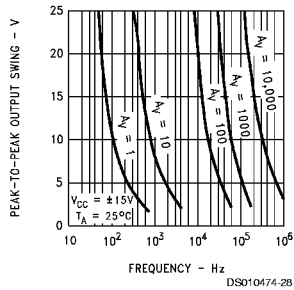

Transient Response

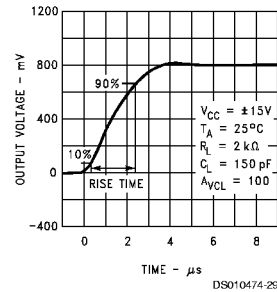

Note 6: Performance is shown using recommended compensation networks.

Transient Response Test Circuit

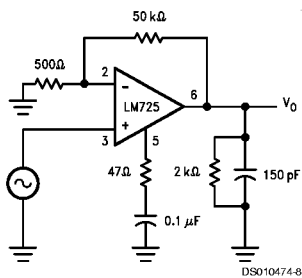

Auxiliary Circuits

Voltage Offset Null Circuit

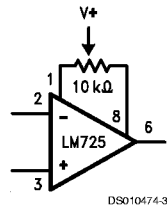

Frequency Compensation Circuit

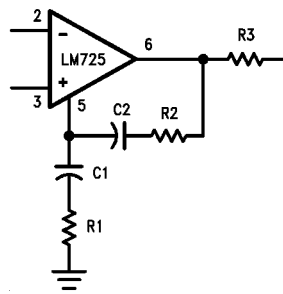

Compensation Component Values

A_V	R_1 (Ω)	C_1 (μF)	R_2 (Ω)	C_2 (μF)
10,000	10k	50 pF		
1,000	470	0.001		
100	47	0.01		
10	27	0.05	270	0.0015
1	10	0.05	39	0.02

Typical Applications

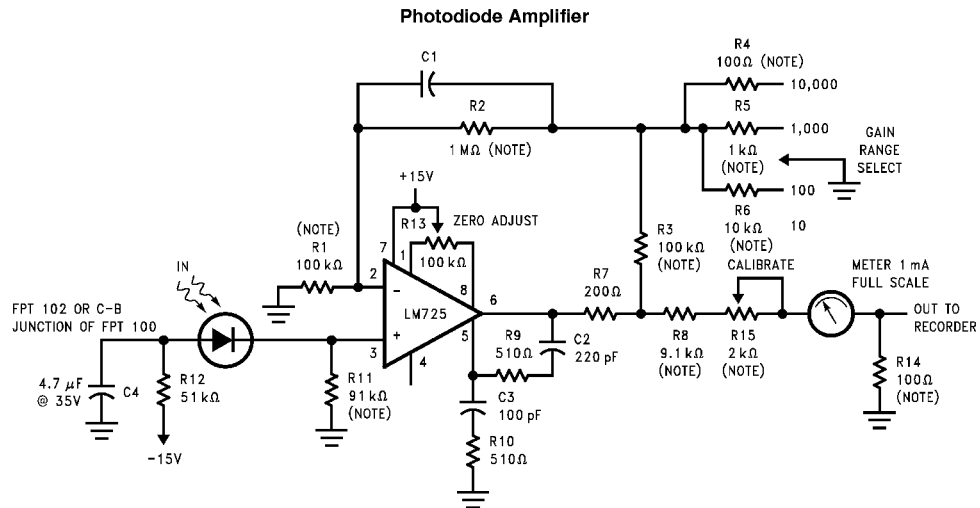

DS010474-9

DC Gains = 10,000; 1,000; 100; and 10
Bandwidth = Determined by value of C1

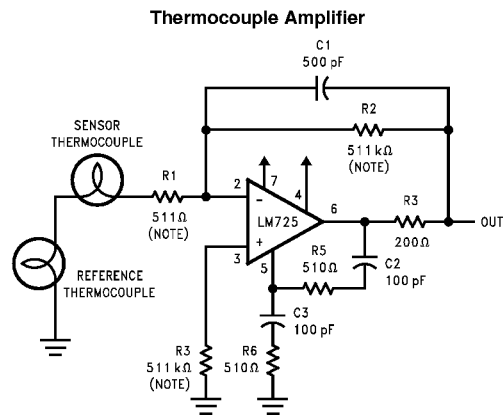

DS010474-10

$$\frac{R2}{R5} = \frac{R6}{R7} \text{ for best CMR}$$

$$R1 = R4$$

$$R2 = R5$$

$$\text{Gain} = \frac{R6}{R2} + \left(\frac{2R1}{R3} \right)$$

$$\text{DC Gain} = 1000$$

$$\text{Bandwidth} = \text{DC to } 540 \text{ Hz}$$

$$\text{Equivalent Input Noise} = 0.24 \mu\text{V}_{\text{rms}}$$

Note: Indicates $\pm 1\%$ metal film resistors recommended for temperature stability.

Typical Applications (Continued)

±100V Common Mode Range Differential Amplifier

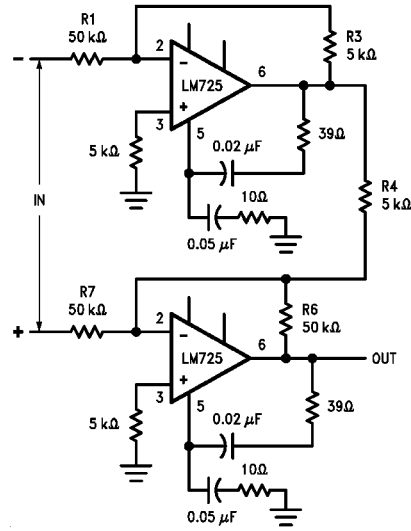

DS010474-11

Instrumentation Amplifier with High Common Mode Rejection

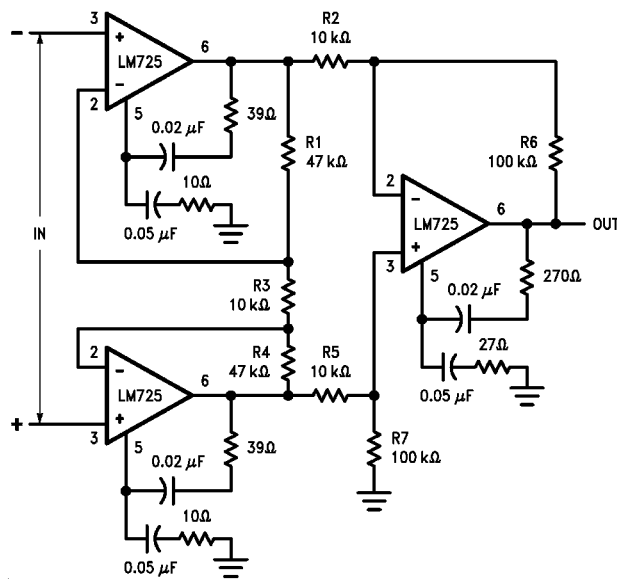

DS010474-12

$$\frac{R1}{R6} = \frac{R3}{R4} \text{ for best CMRR}$$

$$R3 = R4$$

$$R1 = R6 = 10 R3$$

$$\text{Gain} = \frac{R6}{R7}$$

Typical Applications (Continued)

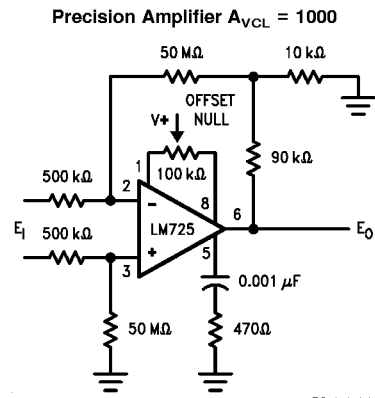

Notes

LIFE SUPPORT POLICY

NATIONAL'S PRODUCTS ARE NOT AUTHORIZED FOR USE AS CRITICAL COMPONENTS IN LIFE SUPPORT DEVICES OR SYSTEMS WITHOUT THE EXPRESS WRITTEN APPROVAL OF THE PRESIDENT OF NATIONAL SEMICONDUCTOR CORPORATION. As used herein:

1. Life support devices or systems are devices or systems which, (a) are intended for surgical implant into the body, or (b) support or sustain life, and whose failure to perform when properly used in accordance with instructions for use provided in the labeling, can be reasonably expected to result in a significant injury to the user.
2. A critical component is any component of a life support device or system whose failure to perform can be reasonably expected to cause the failure of the life support device or system, or to affect its safety or effectiveness.

 **National Semiconductor Corporation**
Americas
Tel: 1-800-272-9959
Fax: 1-800-737-7018
Email: support@nsc.com

www.national.com

National Semiconductor Europe
Fax: +49 (0) 1 80-530 85 86
Email: europe.support@nsc.com
Deutsch Tel: +49 (0) 1 80-530 85 85
English Tel: +49 (0) 1 80-532 78 32
Français Tel: +49 (0) 1 80-532 93 58
Italiano Tel: +49 (0) 1 80-534 16 80

National Semiconductor Asia Pacific Customer Response Group
Tel: 65-2544466
Fax: 65-2504466
Email: sea.support@nsc.com

National Semiconductor Japan Ltd.
Tel: 81-3-5639-7560
Fax: 81-3-5639-7507