



Micro Power Systems

T-51-09-12

**MP7541B**CMOS  
Multiplying 12-Bit  
Digital-to-Analog Converter**FEATURES**

- Full Four Quadrant Multiplication
- Low Glitch Energy
- 12-Bit Linearity (End-Point)
- Guaranteed Monotonic. All Grades. All Temperatures.
- TTL/CMOS Compatible
- Stable, More Accurate Segmented Architecture
  - 2.0 ppm/°C Typ. Gain Error Tempco
  - 0.2 ppm/°C Max. Linearity Tempco
  - Lowest Sensitivity to Output Amplifier Offset
- PDIP, CDIP & SOIC Packages Available
- ESD Protection: 2000 V Minimum
- Latch-Up Free

**APPLICATIONS**

- Industrial Automation
- Automatic Test Equipment
- Disk Drive Servo Systems
- Digital/Synchro Conversion
- Programmable Gain Amplifiers
- Ratiometric A/D Conversion
- Function Generation
- Digitally Controlled Filters

**GENERAL DESCRIPTION**

The MP7541B is a pin-compatible replacement which offers superior performance in latch-up and ESD protection versus the comparable 7541 and 7541A. The high ESD protection will reduce failures caused by mishandling. These devices are manufactured using MPS' patented advanced thin film resistors on a double metal CMOS process which result in ultra stable thin film and superior long life reliability and stability. The MP7541B incorporates a bit decoding technique yielding lower glitch, higher speed and excellent accuracy over temperature and time. The MP7541B's outstanding features are:

**Stability:** Both Integral-Non-Linearity and Differential-Non-Linearity are rated at 0.2 ppm/°C maximum. Monotonicity is guaranteed over the entire temperature range. Gain Temperature Coefficient (TCGE) is 2.0 ppm/°C typical.

**Lower Sensitivity to Output Amplifier Offset:** Multiplying DACs provide an output current into a virtual ground of the output op amp. Additional linearity error caused by the op amp is reduced by a factor of 3 in the MP7541B versus conventional R-2R DACs.

Specified for operation over the commercial / industrial (–40 to +85°C) and Military (–55 to +125°C) temperature ranges, the MP7541B is available in Plastic (PDIP) and Ceramic (CDIP) dual-in-line and Surface Mount (SOIC) packages.

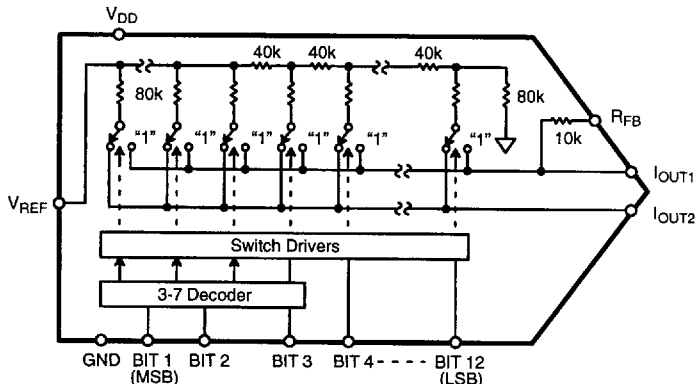
**SIMPLIFIED BLOCK DIAGRAM**



# MP7541B

## ORDERING INFORMATION

Package Type	Temperature Range	Part No.	INL (LSB)	DNL (LSB)	Gain Error (LSB)
Plastic Dip	-40 to +85°C	MP7541BKN	±1/2	±1/2	±5
Plastic Dip	-40 to +85°C	MP7541BJN	±1	±1	±8
SOIC	-40 to +85°C	MP7541BKS*	±1/2	±1/2	±5
SOIC	-40 to +85°C	MP7541BJS*	±1	±1	±8
Ceramic Dip	-55 to +125°C	MP7541BTD*	±1/2	±1/2	±5
Ceramic Dip	-55 to +125°C	MP7541BTD/883*	±1/2	±1/2	±5
Ceramic Dip	-55 to +125°C	MP7541BSD*	±1	±1	±8
Ceramic Dip	-55 to +125°C	MP7541BSD/883*	±1	±1	±8

\*Contact factory for availability.

## PIN CONFIGURATIONS

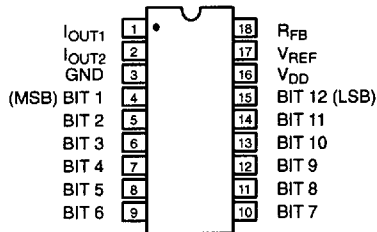

18 Pin PDIP, CDIP (0.300")  
N18, D18

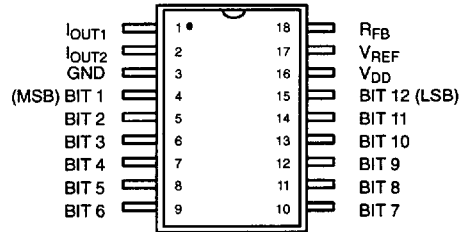

18 Pin SOIC (Jedec, 0.300")  
S18

## PIN OUT DEFINITIONS

PIN NO.	NAME	DESCRIPTION
1	I <sub>OUT1</sub>	Current Output 1
2	I <sub>OUT2</sub>	Current Output 2
3	GND	Ground
4	BIT 1	Data Input Bit 1 (MSB)
5	BIT 2	Data Input Bit 2
6	BIT 3	Data Input Bit 3
7	BIT 4	Data Input Bit 4
8	BIT 5	Data Input Bit 5
9	BIT 6	Data Input Bit 6

PIN NO.	NAME	DESCRIPTION
10	BIT 7	Data Input Bit 7
11	BIT 8	Data Input Bit 8
12	BIT 9	Data Input Bit 9
13	BIT 10	Data Input Bit 10
14	BIT 11	Data Input Bit 11
15	BIT 12	Data Input Bit 12 (LSB)
16	V <sub>DD</sub>	Positive Power Supply
17	V <sub>REF</sub>	Reference Input Voltage
18	R <sub>FB</sub>	Internal Feedback Resistor



Micro Power Systems

**MP7541B****ELECTRICAL CHARACTERISTICS** $V_{DD} = +15\text{ V}$ ,  $V_{REF} = +10\text{ V}$ ,  $I_{OUT1} = I_{OUT2} = \text{GND} = 0\text{ V}$  Unless Otherwise Noted.

Parameter	Symbol	25°C			Tmin to Tmax		Units	Test Conditions/Comments
		Min	Typ	Max	Min	Max		
<b>STATIC PERFORMANCE (1)</b>								
Resolution (All Grades)	N	12			12		Bits	
Integral Non-Linearity (Relative Accuracy) K, T J, S	INL			$\pm 1/2$ $\pm 1$		$\pm 1/2$ $\pm 1$	LSB	End Point Linearity
Differential Non-Linearity K, T J, S	DNL			$\pm 1/2$ $\pm 1$		$\pm 1/2$ $\pm 1$	LSB	All grades monotonic over full temperature range.
Gain Error K, T J, S	GE			$\pm 3$ $\pm 6$		$\pm 5$ $\pm 8$	LSB	Using Internal $R_{FB}$
Gain Temperature Coefficient (2)	$TC_{GE}$					$\pm 2$	ppm/°C	$\Delta\text{Gain}/\Delta\text{Temperature}$
Power Supply Rejection Ratio	PSRR		5	$\pm 50$		$\pm 100$	ppm/%	$ \Delta\text{Gain}/\Delta V_{DD} $ $\Delta V_{DD} = \pm 5\%$
Output Leakage Current	$I_{LKG}$		5	$\pm 10$		$\pm 200$	nA	Digital Inputs = 0 or 5 V
<b>DYNAMIC PERFORMANCE (2)</b>								
Current Settling Time	$t_S$		0.65	1.0			$\mu\text{s}$	Full scale change to 1/2 LSB
AC Feedthrough at $I_{OUT1}$	$F_T$		1.0				mV p-p	$V_{REF} = 20\text{ V p-p}$ 10kHz, Sinewave
Glitch Energy	E <sub>gl</sub>		500				nVs	00--0 to 11--1 Input Change
Propagation Delay	$t_{PD}$		60				ns	From 50% of digital input to 10% of final analog output current
<b>REFERENCE INPUT</b>								
Input Resistance	$R_{IN}$		5	10	20	5	20	k $\Omega$
<b>DIGITAL INPUTS</b>								
Logical "1" Voltage	$V_{IH}$		2.4			2.4		V
Logical "0" Voltage	$V_{IL}$			0.8			0.8	V
Input Leakage Current	$I_{INH}, I_{INL}$			$\pm 1.0$			$\pm 1.0$	$\mu\text{A}$
Input Capacitance (2) Data	$C_{IN}$			8.0			8.0	pF
<b>ANALOG OUTPUTS (2)</b>								
Output Capacitance	$C_{OUT1}$ $C_{OUT1}$ $C_{OUT2}$ $C_{OUT2}$		100 50 50 100				pF pF pF pF	DAC all 1's DAC all 0's DAC all 1's DAC all 0's
<b>POWER SUPPLY (3)</b>								
Functional Voltage Range (2)	$V_{DD}$		4.5	16		4.5	16	V
Supply Current	$I_{DD}$			1.0			1.0	mA
								All Digital Inputs = 0 or 5 V



# MP7541B

## ELECTRICAL CHARACTERISTICS (CONT'D)

### NOTES:

- (1) Full Scale Range (FSR) is 10V for unipolar mode.
- (2) Guaranteed but not production tested.
- (3) Specified values guarantee functionality. Refer to other parameters for accuracy.

Specifications are subject to change without notice

## ABSOLUTE MAXIMUM RATINGS (1, 2) (TA = +25°C unless otherwise noted)

V <sub>DD</sub> to GND	0 to +17 V	Storage Temperature	-65°C to +150°C
Digital Input Voltage to GND	GND -0.5 to V <sub>DD</sub> +0.5 V	Lead Temperature (Soldering, 10 seconds)	+300°C
I <sub>OUT1</sub> , I <sub>OUT2</sub> to GND	GND -0.5 to V <sub>DD</sub> +0.5 V	Package Power Dissipation Rating to 75°C	
V <sub>REF</sub> to GND	±25 V	CDIP, PDIP, SOIC	850mW
V <sub>RFB</sub> to GND	±25 V	Derates above 75°C	11mW/°C

### NOTES:

- (1) Stresses above those listed under "Absolute Maximum Ratings" may cause permanent damage to the device. This is a stress rating only and functional operation at or above this specification is not implied. Exposure to maximum rating conditions for extended periods may affect device reliability.
- (2) Any input pin which can see a value outside the absolute maximum ratings should be protected by Schottky diode clamps (HP5082-2835) from input pin to the supplies. *All inputs have protection diodes* which will protect the device from short transients outside the supplies of less than 20mA for less than 100µs.

## APPLICATION NOTES

Refer to Section 8 for Applications Information

## PERFORMANCE CHARACTERISTICS

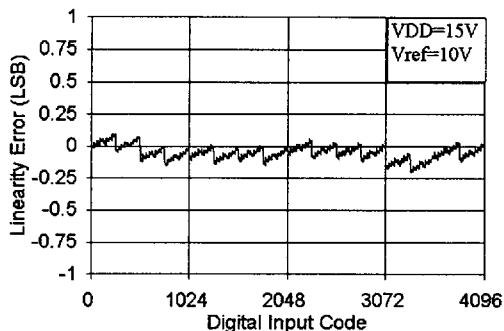

Graph 1. Linearity Error vs. Digital Input Code