

### Features

- ◇ Glass passivated chip junction
- ◇ High efficiency, Low VF
- ◇ High current capability
- ◇ High reliability
- ◇ High surge current capability
- ◇ For use in low voltage, high frequency inverter, free wheeling, and polarity protection application
- ◇ Green compound with suffix "G" on packing code & prefix "G" on datecode



### Mechanical Data

- ◇ Case: Molded plastic
- ◇ Epoxy: UL 94V-0 rate flame retardant
- ◇ Lead: Pure tin plated, lead free, solderable per MIL-STD-202, Method 208 guaranteed
- ◇ Polarity: Color band denotes cathode
- ◇ High temperature soldering guaranteed: 260°C/10 seconds
- ◇ Weight: 1.65 grams

### Ordering Information (example)

Part No.	Package	Packing	INNER TAPE	Packing code	Packing code (Green)
HER601G	R-6	700 / AMMO box	52mm	A0	A0G

### Maximum Ratings and Electrical Characteristics

Rating at 25 °C ambient temperature unless otherwise specified.

Parameter	Symbol	HER 601G	HER 602G	HER 603G	HER 604G	HER 605G	HER 606G	HER 607G	HER 608G	Units	
Maximum Recurrent Peak Reverse Voltage	$V_{RRM}$	50	100	200	300	400	600	800	1000	V	
Maximum RMS Voltage	$V_{RMS}$	35	70	140	210	280	420	560	700	V	
Maximum DC Blocking Voltage	$V_{DC}$	50	100	200	300	400	600	800	1000	V	
Maximum Average Forward Rectified Current	$I_{F(AV)}$	6								A	
Peak Forward Surge Current, 8.3 ms Single Half Sine-wave Superimposed on Rated Load (JEDEC method)	$I_{FSM}$	150								A	
Maximum Instantaneous Forward Voltage (Note 1) @ 6 A	$V_F$	1.0			1.3		1.7			V	
Maximum DC Reverse Current @ $T_A=25\text{ }^\circ\text{C}$ at Rated DC Blocking Voltage @ $T_A=125\text{ }^\circ\text{C}$	$I_R$	10					200				uA uA
Maximum Reverse Recovery Time (Note 2)	$T_{rr}$	50					75				nS
Typical Junction Capacitance (Note 3)	$C_j$	80					65				pF
Typical Thermal Resistance	$R_{\theta JA}$	37								$^\circ\text{C/W}$	
Operating Temperature Range	$T_J$	- 55 to + 150								$^\circ\text{C}$	
Storage Temperature Range	$T_{STG}$	- 55 to + 150								$^\circ\text{C}$	

Note 1: Pulse Test with PW=300 usec, 1% Duty Cycle

Note 2: Reverse Recovery Test Conditions:  $I_F=0.5\text{A}$ ,  $I_R=1.0\text{A}$ ,  $IRR=0.25\text{A}$

Note 3: Measured at 1 MHz and Applied Reverse Voltage of 4.0V D.C.

RATINGS AND CHARACTERISTIC CURVES (HER601G THRU HER608G)

FIG. 1- MAXIMUM FORWARD CURRENT DERATING CURVE

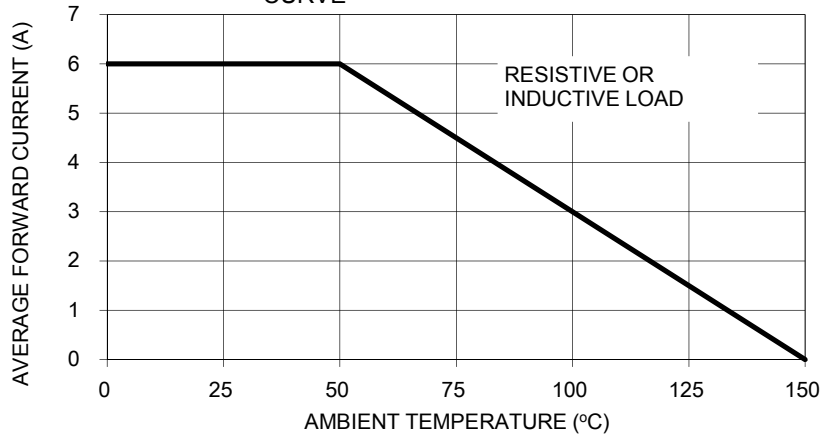

FIG. 2- TYPICAL REVERSE CHARACTERISTICS

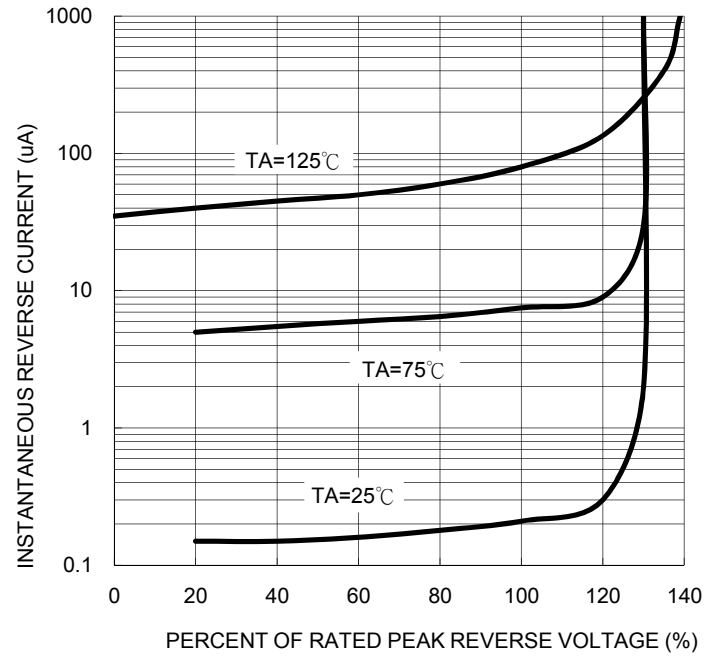

FIG. 3- MAXIMUM NON-REPETITIVE FORWARD SURGE CURRENT

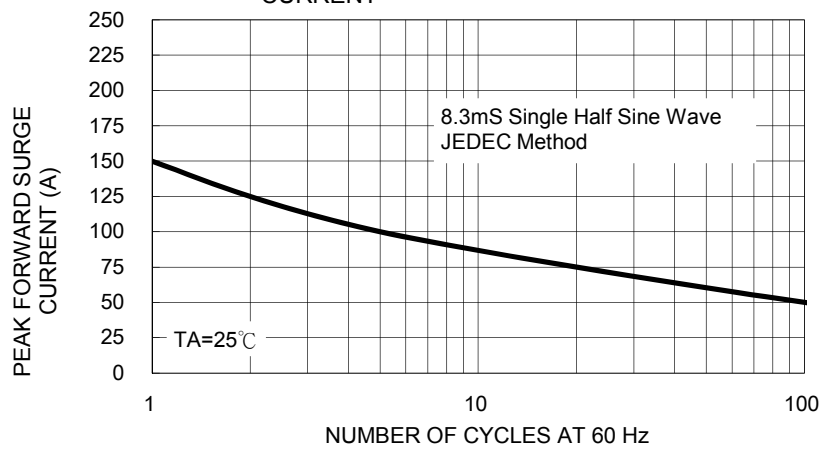

FIG. 5- TYPICAL FORWARD CHARACTERISTICS

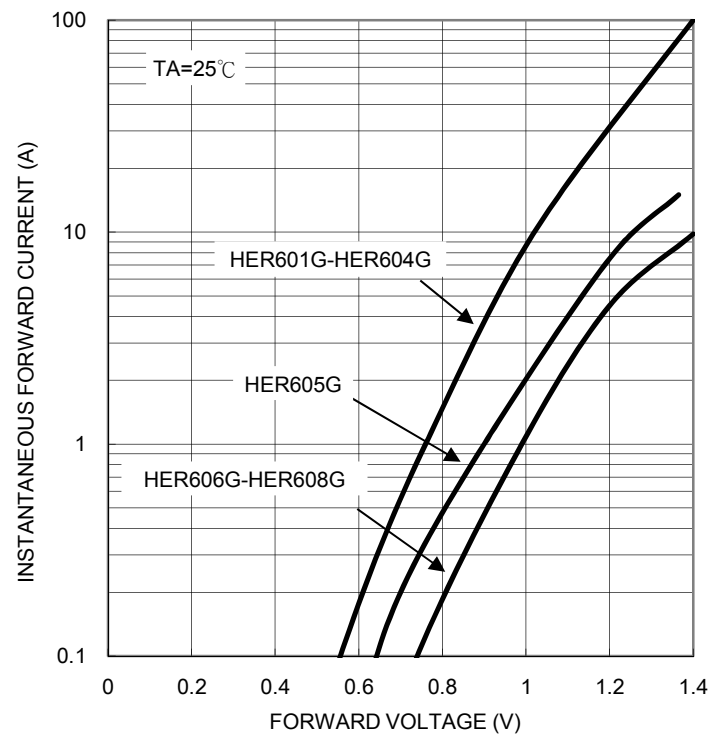

FIG. 4- TYPICAL JUNCTION CAPACITANCE

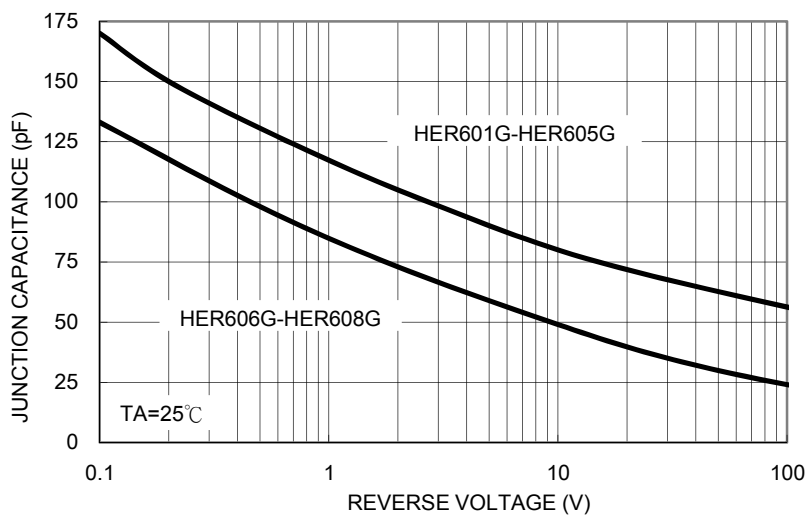
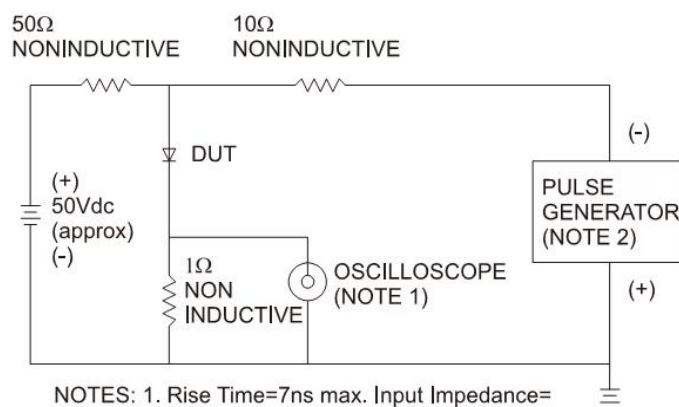
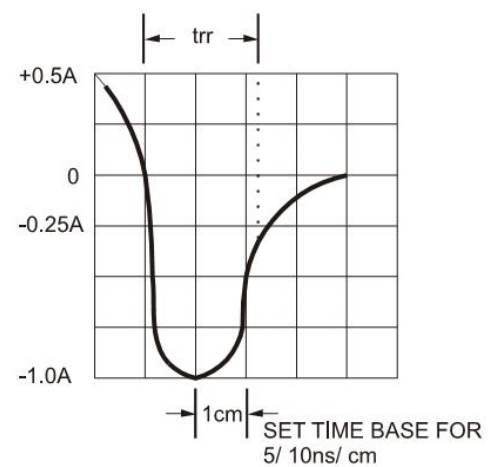

FIG. 6- REVERSE RECOVERY TIME CHARACTERISTIC AND TEST CIRCUIT DIAGRAM



NOTES: 1. Rise Time=7ns max. Input Impedance= 1 megohm 22pf  
2. Rise Time=10ns max. Source Impedance= 50 ohms



**Ordering information**

Part No.	Package	Packing	INNER TAPE	Packing code	Packing code (Green)
HER60xG (Note)	R-6	700 / AMMO box	52mm	A0	A0G
	R-6	1 K / 13" Reel	52mm	R0	R0G
	R-6	400 / Bulk packing		B0	B0G

Note: "x" is Device Code from "1" thru "8".

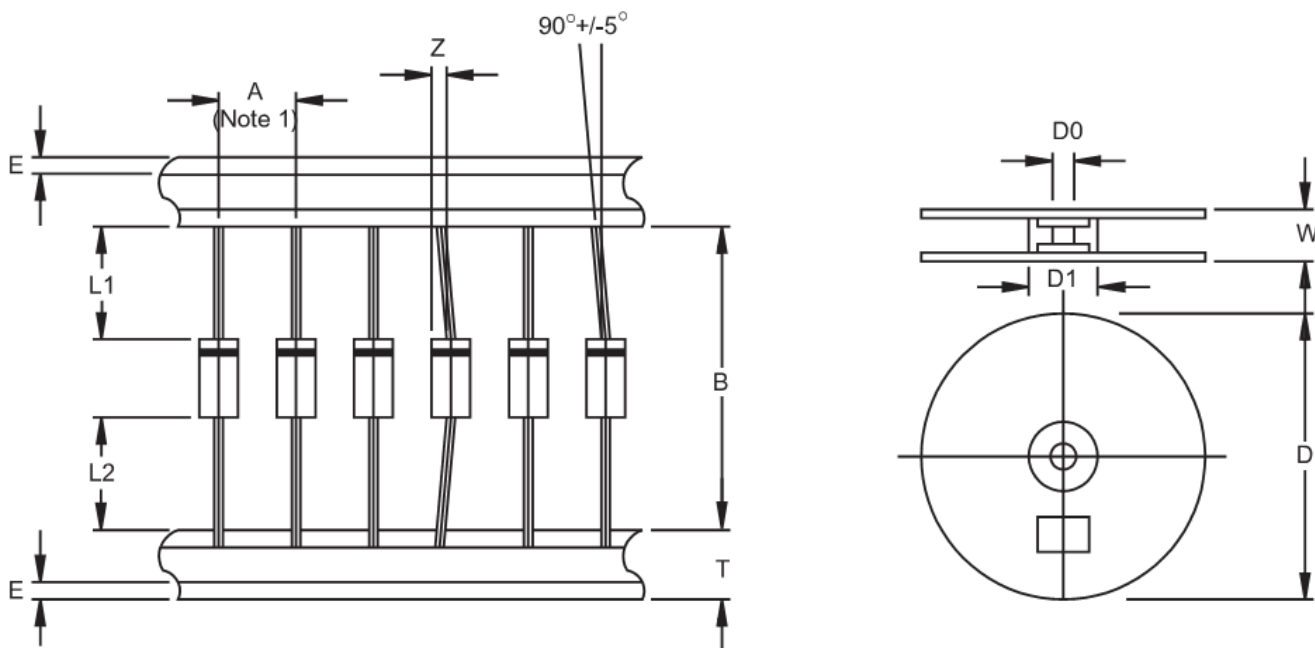
**AXIAL LEAD TAPING SPECIFICATIONS**

Outline	A	B	Z	T	E	L1-L2	D	D1	D0	W
		±0.5	±1.5	MAX	±0.4	MAX	MAX		±0.3	±0.4
R-6	10	52.4	1.2	6	0.8	1	330	85.7	16.6	76

Unit (mm)

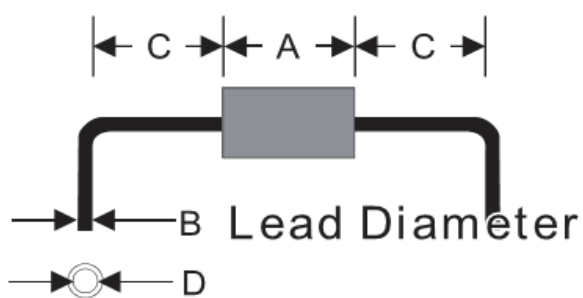
**Suggested Mounting Hole Rule**

Symbol	Unit(mm)
A	8.9
B	1.3
C	4.0
D	1.5

**Dimensions**

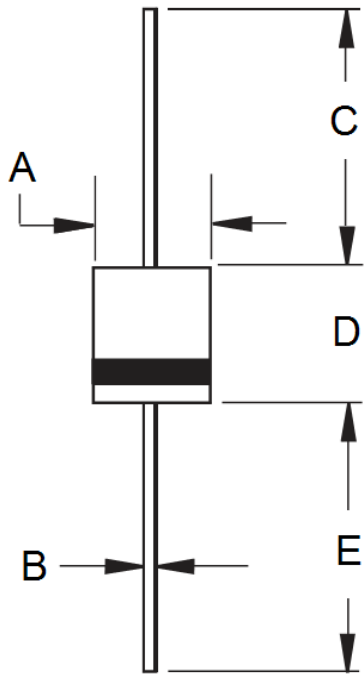

DIM.	Unit(mm)		Unit(inch)	
	Min	Max	Min	Max
A	6.80	7.20	0.268	0.283
B	1.20	1.30	0.047	0.051
C	25.40	-	1.000	-
D	8.60	9.10	0.339	0.358
E	25.40	-	1.000	-

**Marking Diagram**



- P/N = Specific Device Code
- G = Green Compound
- YWW = Date Code
- F = Factory Code