

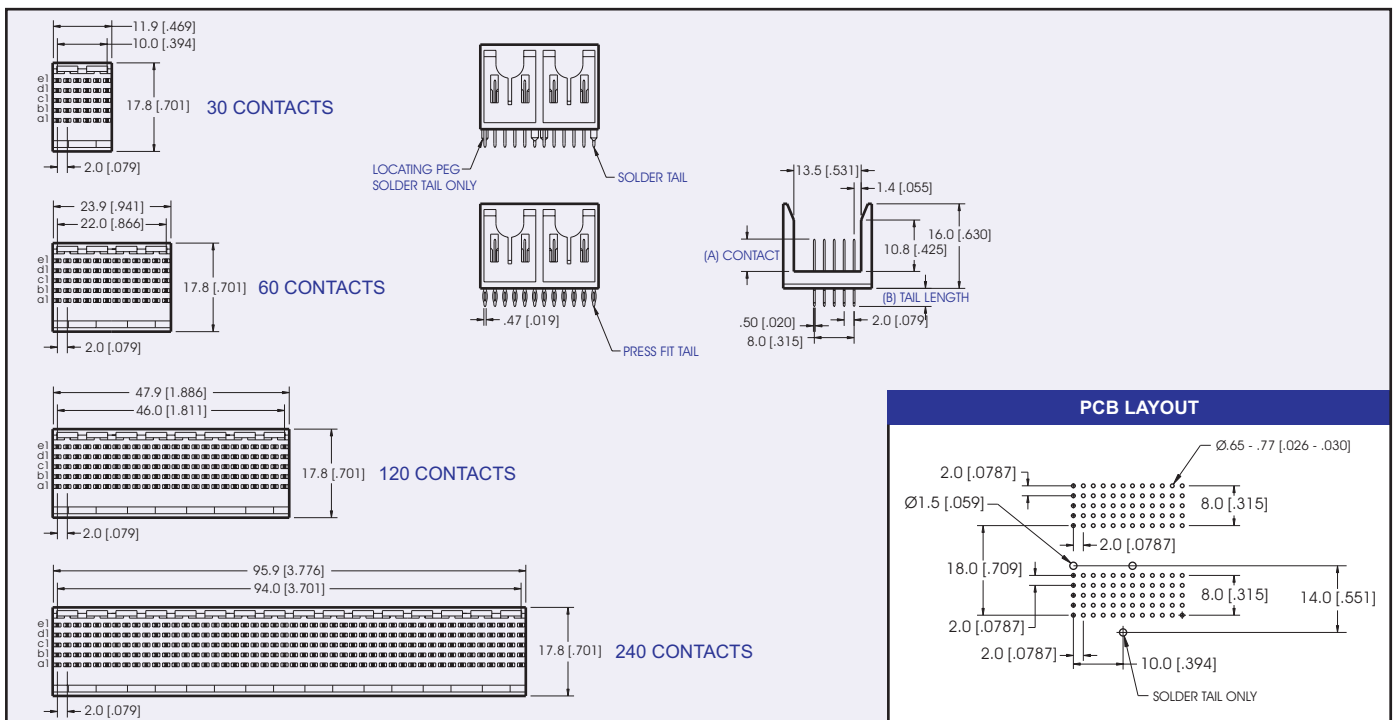

7400 Series Futurebus 5 Row Male Header

Specifications

Insulator Material: Liquid Crystal Polymer (LCP)
94V-O, UL Recognized.
Contact Material: Phosphor Bronze
Contact Plating: Gold and/or Tin over .000050" Ni
(See contact plating options)
Insulation Resistance: 1000 M ohms min.
Contact Resistance: 30 m ohms max.
Dielectric Withstand Voltage: 1000 VAC
Current Rating: 1 AMP
Operating Temperature: -65°C To +125°C
UL File Numbers: E146967 & E176234

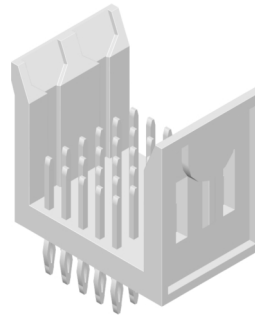

DIMENSIONS ARE IN MM & [INCHES]

PART NUMBERING

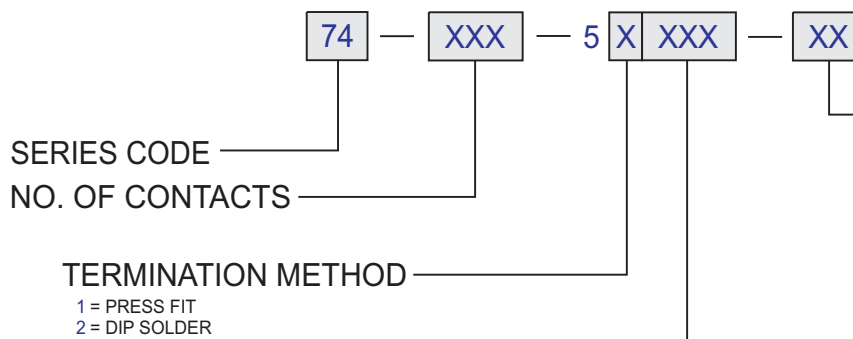

CONTACT LOADING

P/N CODE	001	002	003	101	102	103	201	202	203	301	302	303	401	402	403
TERMINATION*	PF/DS	PF	PF	PF/DS	PF	PF	PF/DS	PF	PF	PF/DS	PF	PF	PF/DS	PF	PF
(A) CONTACT	5.0mm	5.0mm	5.0mm	5.75mm	5.75mm	5.75mm	6.5mm	6.5mm	6.5mm	7.25mm	7.25mm	7.25mm	8.0mm	8.0mm	8.0mm
(B) TAIL LENGTH	4.3mm	13.6mm	17.0mm	4.3mm	13.6mm	17.0mm	4.3mm	13.6mm	17.0mm	4.3mm	13.6mm	17.0mm	4.3mm	13.6mm	17.0mm

*PF = PRESS FIT
DS = DIP SOLDER

FOR CUSTOM LOADED CONNECTORS PLEASE USE CUSTOMER REQUEST FORM ON PAGE D-47