

SN54150, SN54151A, SN54LS151, SN54S151, SN74150, SN74151A, SN74LS151, SN74S151 DATA SELECTORS/MULTIPLEXERS

DECEMBER 1972—REVISED MARCH 1988

- '150 Selects One-of-Sixteen Data Sources
- Others Select One-of-Eight Data Sources
- All Perform Parallel-to-Serial Conversion
- All Permit Multiplexing from N Lines to One Line
- Also For Use as Boolean Function Generator
- Input-Clamping Diodes Simplify System Design
- Fully Compatible with Most TTL Circuits

TYPE	TYPICAL AVERAGE	TYPICAL
	PROPAGATION DELAY TIME DATA INPUT TO W OUTPUT	POWER DISSIPATION
'150	13 ns	200 mW
'151A	8 ns	145 mW
'LS151	13 ns	30 mW
'S151	4.5 ns	225 mW

description

These monolithic data selectors/multiplexers contain full on-chip binary decoding to select the desired data source. The '150 selects one-of-sixteen data sources; the '151A, 'LS151, and 'S151 select one-of-eight data sources. The '150, '151A, 'LS151, and 'S151 have a strobe input which must be at a low logic level to enable these devices. A high level at the strobe forces the W output high, and the Y output (as applicable) low.

The '150 has only an inverted W output; the '151A, 'LS151, and 'S151 feature complementary W and Y outputs.

The '151A and '152A incorporate address buffers that have symmetrical propagation delay times through the complementary paths. This reduces the possibility of transients occurring at the output(s) due to changes made at the select inputs, even when the '151A outputs are enabled (i.e., strobe low).

SN54150 . . . J OR W PACKAGE

SN74150 . . . N PACKAGE

(TOP VIEW)

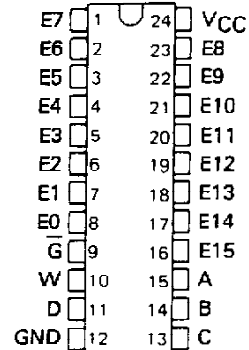

SN54151A, SN54LS151, SN54S151 . . . J OR W PACKAGE

SN74151A . . . N PACKAGE

SN74LS151, SN74S151 . . . D OR N PACKAGE

(TOP VIEW)

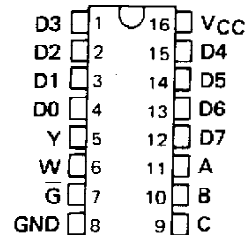

SN54LS151, SN54S151 . . . FK PACKAGE

(TOP VIEW)

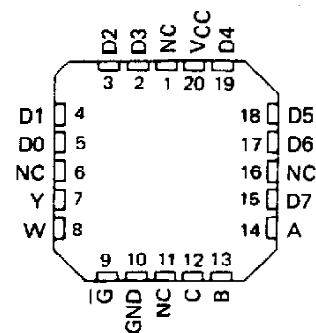

NC - No internal connection

PRODUCTION DATA documents contain information current as of publication date. Products conform to specifications per the terms of Texas Instruments standard warranty. Production processing does not necessarily include testing of all parameters.

TEXAS
INSTRUMENTS

POST OFFICE BOX 655012 • DALLAS, TEXAS 75265

**SN54150, SN54151A, SN54LS151, SN54S151,
SN74150, SN74151A, SN74LS151, SN74S151
DATA SELECTORS/MULTIPLEXERS**

logic symbols†

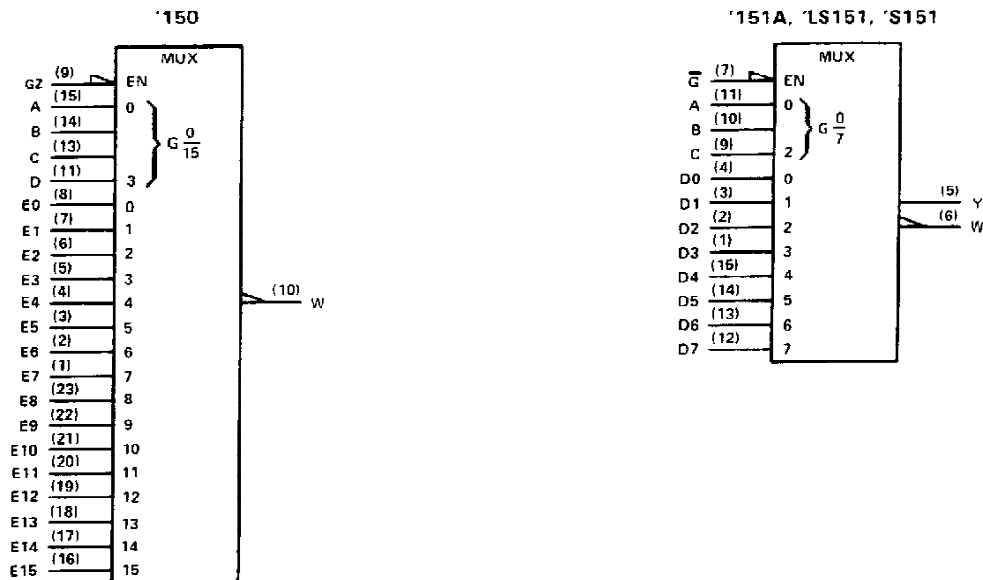

†These symbols are in accordance with ANSI/IEEE Std. 91-1984 and IEC Publication 617-12. Pin numbers shown are D, J, N, and W packages.

'150
FUNCTION TABLE

INPUTS					STROBE \bar{G}	OUTPUT W
SELECT						
D	C	B	A			
X	X	X	X	H	H	
L	L	L	L	L	$\bar{E0}$	
L	L	L	H	L	$\bar{E1}$	
L	L	H	L	L	$\bar{E2}$	
L	L	H	H	L	$\bar{E3}$	
L	H	L	L	L	$\bar{E4}$	
L	H	L	H	L	$\bar{E5}$	
L	H	H	L	L	$\bar{E6}$	
L	H	H	H	L	$\bar{E7}$	
H	L	L	L	L	$\bar{E8}$	
H	L	L	H	L	$\bar{E9}$	
H	L	H	L	L	$\bar{E10}$	
H	L	H	H	L	$\bar{E11}$	
H	H	L	L	L	$\bar{E12}$	
H	H	L	H	L	$\bar{E13}$	
H	H	H	L	L	$\bar{E14}$	
H	H	H	H	L	$\bar{E15}$	

'151A, 'LS151, 'S151
FUNCTION TABLE

INPUTS				OUTPUTS	
SELECT			STROBE \bar{G}	Y	W
C	B	A			
X	X	X	H	L	H
L	L	L	L	L	$\bar{D0}$
L	L	H	L	L	$\bar{D1}$
L	H	L	L	L	$\bar{D2}$
L	H	H	L	L	$\bar{D3}$
H	L	L	L	L	$\bar{D4}$
H	L	H	L	L	$\bar{D5}$
H	H	L	L	L	$\bar{D6}$
H	H	H	L	L	$\bar{D7}$

H = high level, L = low level, X = irrelevant
 $\bar{E0}, \bar{E1} \dots \bar{E15}$ = the complement of the level of the respective E input
 $\bar{D0}, \bar{D1} \dots \bar{D7}$ = the level of the D respective input



**SN54150, SN54151A, SN54LS151, SN54S151
SN74150, SN74151A, SN74LS151, SN74S151
DATA SELECTORS/MULTIPLEXERS**

schematics of inputs and outputs

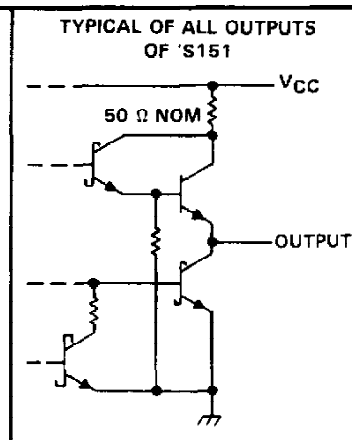
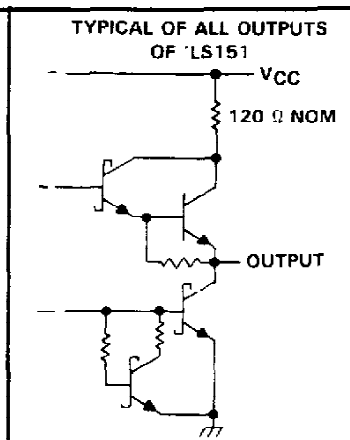
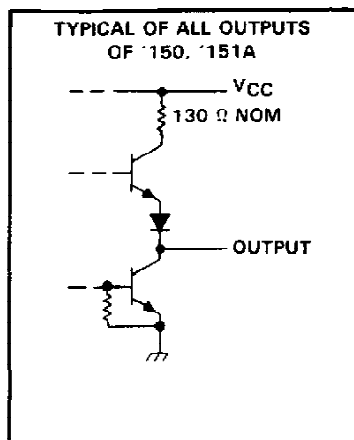
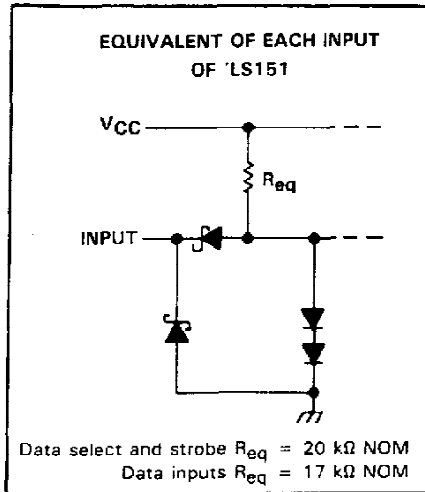
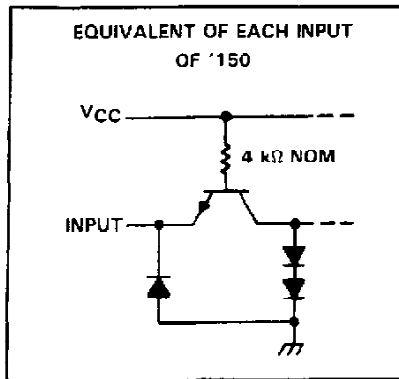

SN54150, SN54151A, SN74150, SN74151A DATA SELECTORS/MULTIPLEXERS

recommended operating conditions

	SN54'			SN74'			UNIT
	MIN	NOM	MAX	MIN	NOM	MAX	
Supply voltage, V_{CC}	4.5	5	5.5	4.75	5	5.25	V
High-level output current, I_{OH}			-800			-800	μ A
Low-level output current, I_{OL}			16			16	mA
Operating free-air temperature, T_A	-55		125	0		70	$^{\circ}$ C

electrical characteristics over recommended operating free-air temperature range (unless otherwise noted)

PARAMETER	TEST CONDITIONS [†]	'150			'151A			UNIT
		MIN	TYP [‡]	MAX	MIN	TYP [‡]	MAX	
V_{IH} High-level input voltage		2			2			V
V_{IL} Low-level input voltage				0.8			0.8	V
V_{IK} Input clamp voltage	$V_{CC} = \text{MIN}$, $I_I = -8 \text{ mA}$			-1.5			-1.5	V
V_{OH} High-level output voltage	$V_{CC} = \text{MIN}$, $V_{IH} = 2 \text{ V}$, $V_{IL} = 0.8 \text{ V}$, $I_{OH} = -800 \mu\text{A}$	2.4	3.4		2.4	3.4		V
V_{OL} Low-level output voltage	$V_{CC} = \text{MIN}$, $V_{IH} = 2 \text{ V}$, $V_{IL} = 0.8 \text{ V}$, $I_{OL} = 16 \text{ mA}$		0.2	0.4		0.2	0.4	V
I_I Input current at maximum input voltage	$V_{CC} = \text{MAX}$, $V_I = 5.5 \text{ V}$			1			1	mA
I_{IH} High-level input current	$V_{CC} = \text{MAX}$, $V_I = 2.4 \text{ V}$			40			40	μ A
I_{IL} Low-level input current	$V_{CC} = \text{MAX}$, $V_I = 0.4 \text{ V}$			-1.6			-1.6	mA
I_{OS} Short-circuit output current [§]	$V_{CC} = \text{MAX}$	SN54'	-20	-55	-20	-55		mA
		SN74'	-18	-55	-18	-55		
I_{CC} Supply current	$V_{CC} = \text{MAX}$. See Note 3		40	68		29	48	mA

[†] For conditions shown as MIN or MAX, use the appropriate value specified under recommended operating conditions for the applicable device type.

[‡] All typical values at $V_{CC} = 5 \text{ V}$, $T_A = 25^{\circ}\text{C}$.

[§] Not more than one output of the '151A should be shorted at a time.

NOTE 3: I_{CC} is measured with the strobe and data select inputs at 4.5 V, all other inputs and outputs open.

switching characteristics, $V_{CC} = 5 \text{ V}$, $T_A = 25^{\circ}\text{C}$

PARAMETER [¶]	FROM (INPUT)	TO (OUTPUT)	TEST CONDITIONS	'150			'151A			UNIT
				MIN	TYP	MAX	MIN	TYP	MAX	
t_{PLH}	A, B, or C (4 levels)	Y	$C_L = 15 \text{ pF}$, $R_L = 400 \Omega$, See Note 4 i				25	38		ns
t_{PHL}							25	38		
t_{PLH}	A, B, C, or D (3 levels)	W		23	35		17	26		ns
t_{PHL}				22	33		19	30		
t_{PLH}	Strobe \bar{G}	Y					21	33		ns
t_{PHL}							22	33		
t_{PLH}	Strobe \bar{G}	W		15.5	24		14	21		ns
t_{PHL}				21	30		15	23		
t_{PLH}	D0 thru D7	Y					13	20		ns
t_{PHL}							18	27		
t_{PLH}	E0 thru E15, or D0 thru D7	W	8.5	14		8	14		ns	
t_{PHL}			13	20		8	14			

[¶] t_{PLH} = propagation delay time, low-to-high-level output

t_{PHL} = propagation delay time, high-to-low-level output

NOTE 4: Load circuits and voltage waveforms are shown in Section 1.

TEXAS
INSTRUMENTS

POST OFFICE BOX 655012 • DALLAS, TEXAS 75265

SN54LS151, SN74LS151 DATA SELECTORS/MULTIPLEXERS

recommended operating conditions

	SN54LS151			SN74LS151			UNIT
	MIN	NOM	MAX	MIN	NOM	MAX	
Supply voltage, V_{CC}	4.5	5	5.5	4.75	5	5.25	V
High-level output current, I_{OH}			-400			-400	μA
Low-level output current, I_{OL}			4			8	mA
Operating free-air temperature, T_A	-55		125	0		70	C

electrical characteristics over recommended operating free-air temperature range (unless otherwise noted)

PARAMETER	TEST CONDITIONS†	SN54LS151			SN74LS151			UNIT	
		MIN	TYP‡	MAX	MIN	TYP‡	MAX		
V_{IH} High-level input voltage		2			2			V	
V_{IL} Low-level input voltage				0.7			0.8	V	
V_{IK} Input clamp voltage	$V_{CC} = \text{MIN}$, $I_I = -18 \text{ mA}$			-1.5			-1.5	V	
V_{OH} High-level output voltage	$V_{CC} = \text{MIN}$, $V_{IH} = 2 \text{ V}$, $V_{IL} = V_{IL\text{max}}$, $I_{OH} = -400 \mu A$	2.5	3.4		2.7	3.4		V	
V_{OL} Low-level output voltage	$V_{CC} = \text{MIN}$, $V_{IH} = 2 \text{ V}$, $V_{IL} = V_{IL\text{max}}$			0.25	0.4		0.25	0.4	V
	$I_{OL} = 4 \text{ mA}$ $I_{OL} = 8 \text{ mA}$						0.35	0.5	
I_I Input current at maximum input voltage	$V_{CC} = \text{MAX}$, $V_I = 7 \text{ V}$			0.1			0.1	mA	
I_{IH} High-level input current	$V_{CC} = \text{MAX}$, $V_I = 2.7 \text{ V}$			20			20	μA	
I_{IL} Low-level input current	$V_{CC} = \text{MAX}$, $V_I = 0.4 \text{ V}$			-0.4			-0.4	mA	
I_{OS} Short-circuit output current‡	$V_{CC} = \text{MAX}$	-20		-100	-20		-100	mA	
I_{CC} Supply current	$V_{CC} = \text{MAX}$, Outputs open, All inputs at 4.5 V		6.0	10		6.0	10	mA	

† For conditions shown as MIN or MAX, use the appropriate value specified under recommended operating conditions for the applicable device type.

‡ All typical values are at $V_{CC} = 5 \text{ V}$, $T_A = 25^\circ\text{C}$.

§ Not more than one output should be shorted at a time and duration of short-circuit should not exceed one second.

switching characteristics, $V_{CC} = 5 \text{ V}$, $T_A = 25^\circ\text{C}$

PARAMETER†	FROM (INPUT)	TO (OUTPUT)	TEST CONDITIONS	MIN	TYP	MAX	UNIT
t_{PLH}	A, B, or C (4 levels)	Y	$C_L = 15 \text{ pF}$, $R_L = 2 \text{ k}\Omega$, See Note 4		27	43	ns
t_{PHL}					18	30	
t_{PLH}	A, B, or C (3 levels)	W			14	23	ns
t_{PHL}					20	32	
t_{PLH}	Strobe \bar{G}	Y			26	42	ns
t_{PHL}					20	32	
t_{PLH}	Strobe \bar{G}	W			15	24	ns
t_{PHL}					18	30	
t_{PLH}	Any D	Y			20	32	ns
t_{PHL}					16	26	
t_{PLH}	Any D	W			13	21	ns
t_{PHL}					12	20	

† t_{PLH} = propagation delay time, low-to-high-level output

t_{PHL} = propagation delay time, high-to-low-level output

NOTE 4: Load circuits and voltage waveforms are shown in Section 1.

**TEXAS
INSTRUMENTS**

POST OFFICE BOX 655012 • DALLAS, TEXAS 75265

SN54S151, SN74S151 DATA SELECTORS/MULTIPLEXERS

recommended operating conditions

	SN54S151			SN74S151			UNIT
	MIN	NOM	MAX	MIN	NOM	MAX	
Supply voltage, V_{CC}	4.5	5	5.5	4.75	5	5.25	V
High-level output current, I_{OH}			-1			-1	mA
Low-level output current, I_{OL}			20			20	mA
Operating free-air temperature, T_A	-55		125	0		70	°C

electrical characteristics over recommended operating free-air temperature range (unless otherwise noted)

PARAMETER	TEST CONDITIONS†	MIN	TYP‡	MAX	UNIT
V_{IH} High-level input voltage		2			V
V_{IL} Low-level input voltage				0.8	V
V_{IK} Input clamp voltage	$V_{CC} = \text{MIN}$, $I_I = -18 \text{ mA}$			-1.2	V
V_{OH} High-level output voltage	$V_{CC} = \text{MIN}$, $V_{IH} = 2 \text{ V}$, $V_{IL} = 0.8 \text{ V}$, $I_{OH} = -1 \text{ mA}$	SN54S151	2.5	3.4	V
		SN74S151	2.7	3.4	
V_{OL} Low-level output voltage	$V_{CC} = \text{MIN}$, $V_{IH} = 2 \text{ V}$, $V_{IL} = 0.8 \text{ V}$, $I_{OL} = 20 \text{ mA}$			0.5	V
I_I Input current at maximum input voltage	$V_{CC} = \text{MAX}$, $V_I = 5.5 \text{ V}$			1	mA
I_{IH} High-level input current	$V_{CC} = \text{MAX}$, $V_I = 2.7 \text{ V}$			50	µA
I_{IL} Low-level input current	$V_{CC} = \text{MAX}$, $V_I = 0.5 \text{ V}$			-2	mA
I_{OS} Short-circuit output current §	$V_{CC} = \text{MAX}$	-40		-100	mA
I_{CC} Supply current	$V_{CC} = \text{MAX}$, All inputs at 4.5 V, All outputs open		45	70	mA

† For conditions shown as MIN or MAX, use the appropriate value specified under recommended operating conditions for the applicable device type.

‡ All typical values are at $V_{CC} = 5 \text{ V}$, $T_A = 25^\circ \text{C}$.

§ Not more than one output should be shorted at a time, and duration of the short-circuit should not exceed one second.

switching characteristics, $V_{CC} = 5 \text{ V}$, $T_A = 25^\circ \text{C}$

PARAMETER†	FROM (INPUT)	TO (OUTPUT)	TEST CONDITIONS	MIN	TYP	MAX	UNIT
t_{PLH}	A, B, or C (4 levels)	Y	$C_L = 15 \text{ pF}$, $R_L = 280 \text{ k}\Omega$, See Note 4		12	18	ns
t_{PHL}					12	18	
t_{PLH}	A, B, or C (3 levels)	W			10	15	ns
t_{PHL}					9	13.5	
t_{PLH}	Any D	Y			8	12	ns
t_{PHL}					8	12	
t_{PLH}	Any D	W			4.5	7	ns
t_{PHL}					4.5	7	
t_{PLH}	Strobe \bar{G}	Y			11	16.5	ns
t_{PHL}					12	18	
t_{PLH}	Strobe \bar{G}	W			9	13	ns
t_{PHL}					8.5	12	

† t_{PLH} = propagation delay time, low-to-high-level output

t_{PHL} = propagation delay time, high-to-low-level output

NOTE 4: Load circuits and voltage waveforms are shown in Section 1.

TEXAS
INSTRUMENTS

POST OFFICE BOX 655012 • DALLAS, TEXAS 75265

IMPORTANT NOTICE

Texas Instruments (TI) reserves the right to make changes to its products or to discontinue any semiconductor product or service without notice, and advises its customers to obtain the latest version of relevant information to verify, before placing orders, that the information being relied on is current.

TI warrants performance of its semiconductor products and related software to the specifications applicable at the time of sale in accordance with TI's standard warranty. Testing and other quality control techniques are utilized to the extent TI deems necessary to support this warranty. Specific testing of all parameters of each device is not necessarily performed, except those mandated by government requirements.

Certain applications using semiconductor products may involve potential risks of death, personal injury, or severe property or environmental damage ("Critical Applications").

TI SEMICONDUCTOR PRODUCTS ARE NOT DESIGNED, INTENDED, AUTHORIZED, OR WARRANTED TO BE SUITABLE FOR USE IN LIFE-SUPPORT APPLICATIONS, DEVICES OR SYSTEMS OR OTHER CRITICAL APPLICATIONS.

Inclusion of TI products in such applications is understood to be fully at the risk of the customer. Use of TI products in such applications requires the written approval of an appropriate TI officer. Questions concerning potential risk applications should be directed to TI through a local SC sales office.

In order to minimize risks associated with the customer's applications, adequate design and operating safeguards should be provided by the customer to minimize inherent or procedural hazards.

TI assumes no liability for applications assistance, customer product design, software performance, or infringement of patents or services described herein. Nor does TI warrant or represent that any license, either express or implied, is granted under any patent right, copyright, mask work right, or other intellectual property right of TI covering or relating to any combination, machine, or process in which such semiconductor products or services might be or are used.

IMPORTANT NOTICE

Texas Instruments and its subsidiaries (TI) reserve the right to make changes to their products or to discontinue any product or service without notice, and advise customers to obtain the latest version of relevant information to verify, before placing orders, that information being relied on is current and complete. All products are sold subject to the terms and conditions of sale supplied at the time of order acknowledgement, including those pertaining to warranty, patent infringement, and limitation of liability.

TI warrants performance of its semiconductor products to the specifications applicable at the time of sale in accordance with TI's standard warranty. Testing and other quality control techniques are utilized to the extent TI deems necessary to support this warranty. Specific testing of all parameters of each device is not necessarily performed, except those mandated by government requirements.

CERTAIN APPLICATIONS USING SEMICONDUCTOR PRODUCTS MAY INVOLVE POTENTIAL RISKS OF DEATH, PERSONAL INJURY, OR SEVERE PROPERTY OR ENVIRONMENTAL DAMAGE ("CRITICAL APPLICATIONS"). TI SEMICONDUCTOR PRODUCTS ARE NOT DESIGNED, AUTHORIZED, OR WARRANTED TO BE SUITABLE FOR USE IN LIFE-SUPPORT DEVICES OR SYSTEMS OR OTHER CRITICAL APPLICATIONS. INCLUSION OF TI PRODUCTS IN SUCH APPLICATIONS IS UNDERSTOOD TO BE FULLY AT THE CUSTOMER'S RISK.

In order to minimize risks associated with the customer's applications, adequate design and operating safeguards must be provided by the customer to minimize inherent or procedural hazards.

TI assumes no liability for applications assistance or customer product design. TI does not warrant or represent that any license, either express or implied, is granted under any patent right, copyright, mask work right, or other intellectual property right of TI covering or relating to any combination, machine, or process in which such semiconductor products or services might be or are used. TI's publication of information regarding any third party's products or services does not constitute TI's approval, warranty or endorsement thereof.



REAL WORLD SIGNAL PROCESSING™

Search TI

[PRODUCTS](#) ▶ [APPLICATIONS](#) ▶ [SUPPORT](#) ▶ [TI&ME](#) ▶

[Advanced Search](#)

PRODUCT FOLDER | PRODUCT INFO: [FEATURES](#) | [DESCRIPTION](#) | [DATASHEETS](#) | [PRICING/AVAILABILITY/PKG](#) | [APPLICATION NOTES](#) | [RELATED DOCUMENTS](#)

PRODUCT SUPPORT: [TRAINING](#)

SN74S151, 8-Line To 1-Line Data Selectors/Multiplexers

DEVICE STATUS: **ACTIVE**

PARAMETER NAME	SN54S151	SN74S151
Voltage Nodes (V)	5	5
Vcc range (V)	4.5 to 5.5	4.75 to 5.25
Input Level	TTL	TTL
Output Level	TTL	TTL
Output Drive (mA)		-1/20
Output	2S	2S
From	8	8
To	1	1

FEATURES

[▲Back to Top](#)

- '150 Selects One-of-Sixteen Data Sources
- Others Select One-of-Eight Data Sources
- All Perform Parallel-to-Serial Conversion
- All Permit Multiplexing from N Lines to One Line
- Also For Use as Boolean Function Generator
- Input-Clamping Diodes Simplify System Design
- Fully Compatible with Most TTL Circuits

DESCRIPTION

[▲Back to Top](#)

These monolithic data selectors/multiplexers contain full on-chip binary decoding to select the desired data source. The '150 selects one-of-sixteen data sources; the '151A, 'LS151, and 'S151 select one-of-eight data sources. The '150, '151A, 'LS151, and 'S151 have a strobe input which must be at a low logic level to enable these devices. A high level at the strobe forces the W output high, and the Y output (as applicable) low.

The '150 has only an inverted W output; the '151A, 'LS151, and 'S151 feature complementary W and Y outputs.

The '151A and '152A incorporate address buffers that have symmetrical propagation delay times through the complementary paths. This reduces the possibility of transients occurring at the output(s) due to changes made at the select inputs, even when the '151A outputs are enabled (i.e., strobe low).

TECHNICAL DOCUMENTS

[▲Back to Top](#)

To view the following documents, [Acrobat Reader 4.0](#) is required.

To download a document to your hard drive, right-click on the link and choose 'Save'.

DATASHEET

[▲Back to Top](#)

Full datasheet in Acrobat PDF: [sn74s151.pdf](#) (309 KB) (Updated: 03/01/1988)

APPLICATION NOTES

[▲Back to Top](#)

View Application Notes for [Digital Logic](#)

- [Designing With Logic \(Rev. C\)](#) (SDYA009C - Updated: 06/01/1997)
- [Evaluation of Nickel/Palladium/Gold-Finished Surface-Mount Integrated Circuits](#) (SZZA026 - Updated: 06/20/2001)
- [Input and Output Characteristics of Digital Integrated Circuits](#) (SDYA010 - Updated: 10/01/1996)
- [Live Insertion](#) (SDYA012 - Updated: 10/01/1996)

RELATED DOCUMENTS

[▲Back to Top](#)

View Related Documentation for [Digital Logic](#)

- [Logic Reference Guide](#) (SCYB004, 1032 KB - Updated: 10/23/2001)
- [Logic Selection Guide Second Half 2002 \(Rev. R\)](#) (SDYU001R, 4274 KB - Updated: 07/19/2002)
- [Military Semiconductors Selection Guide 2002 \(Rev. B\)](#) (SGYC003B, 1648 KB - Updated: 04/22/2002)

PRICING/AVAILABILITY/PKG

[▲Back to Top](#)

DEVICE INFORMATION

ORDERABLE DEVICE	STATUS	PACKAGE TYPE PINS	TEMP (°C)	PRODUCT CONTENT	BUDGETARY PRICING QTY SUS	STD PACK QTY
SN74S151D	ACTIVE	SOP (D) 16	0 TO 70	View Contents	1KU 0.60	40
SN74S151N	ACTIVE	PDIP (N) 16	0 TO 70	View Contents	1KU 0.59	25
SN74S151N3	OBSOLETE	PDIP (N) 16	0 TO 70	View Contents	1KU	
SN74S151NSR	ACTIVE	SOP (NS) 16		View Contents	1KU 0.59	2000

TI INVENTORY STATUS AS OF 3:00 PM GMT, 26 Sep 2002

IN STOCK	IN PROGRESS QTY DATE	LEAD TIME
9800	1114 03 Oct	5 WKS
	>10k 10 Oct	
	>10k 17 Oct	
	>10k 24 Oct	
N/A*	5025 19 Sep	5 WKS
	11 25 Sep	
	>10k 02 Oct	
	25 03 Oct	
	>10k 04 Oct	
N/A*		Not Available
N/A*	>10k 07 Oct	5 WKS
	>10k 14 Oct	

REPORTED DISTRIBUTOR INVENTORY AS OF 3:00 PM GMT, 26 Sep 2002

DISTRIBUTOR COMPANY REGION	IN STOCK	PURCHASE

Table Data Updated on: 9/26/2002

[Products](#) | [Applications](#) | [Support](#) | [TI&ME](#)



TEXAS INSTRUMENTS

© Copyright 1995-2002 Texas Instruments Incorporated. All rights reserved.

[Trademarks](#) | [Privacy Policy](#) | [Terms of Use](#)

PRODUCT FOLDER | PRODUCT INFO: [FEATURES](#) | [DESCRIPTION](#) | [DATASHEETS](#) | [PRICING/AVAILABILITY/PKG](#) | [APPLICATION NOTES](#) | [RELATED DOCUMENTS](#)

PRODUCT SUPPORT: [TRAINING](#)

SN74LS151, 8-Line To 1-Line Data Selectors/Multiplexers

DEVICE STATUS: **ACTIVE**

PARAMETER NAME	SN54LS151	SN74LS151
Voltage Nodes (V)	5	5
Vcc range (V)	4.5 to 5.5	4.75 to 5.25
Input Level	TTL	TTL
Output Level	TTL	TTL
Output Drive (mA)		-0.4/8
Output	2S	2S
From	8	8
To	1	1

FEATURES

[▲Back to Top](#)

- '150 Selects One-of-Sixteen Data Sources
- Others Select One-of-Eight Data Sources
- All Perform Parallel-to-Serial Conversion
- All Permit Multiplexing from N Lines to One Line
- Also For Use as Boolean Function Generator
- Input-Clamping Diodes Simplify System Design
- Fully Compatible with Most TTL Circuits

DESCRIPTION

[▲Back to Top](#)

These monolithic data selectors/multiplexers contain full on-chip binary decoding to select the desired data source. The '150 selects one-of-sixteen data sources; the '151A, 'LS151, and 'S151 select one-of-eight data sources. The '150, '151A, 'LS151, and 'S151 have a strobe input which must be at a low logic level to enable these devices. A high level at the strobe forces the W output high, and the Y output (as applicable) low.

The '150 has only an inverted W output; the '151A, 'LS151, and 'S151 feature complementary W and Y outputs.

The '151A and '152A incorporate address buffers that have symmetrical propagation delay times through the complementary paths. This reduces the possibility of transients occurring at the output(s) due to changes made at the select inputs, even when the '151A outputs are enabled (i.e., strobe low).

TECHNICAL DOCUMENTS

[▲Back to Top](#)

To view the following documents, [Acrobat Reader 4.0](#) is required.

To download a document to your hard drive, right-click on the link and choose 'Save'.

Full datasheet in Acrobat PDF: [sn74ls151.pdf](#) (309 KB) (Updated: 03/01/1988)**APPLICATION NOTES**[▲Back to Top](#)View Application Notes for [Digital Logic](#)

- [Designing With Logic \(Rev. C\)](#) (SDYA009C - Updated: 06/01/1997)
- [Designing with the SN54/74LS123 \(Rev. A\)](#) (SDLA006A - Updated: 03/01/1997)
- [Evaluation of Nickel/Palladium/Gold-Finished Surface-Mount Integrated Circuits](#) (SZZA026 - Updated: 06/20/2001)
- [Input and Output Characteristics of Digital Integrated Circuits](#) (SDYA010 - Updated: 10/01/1996)
- [Live Insertion](#) (SDYA012 - Updated: 10/01/1996)

RELATED DOCUMENTS[▲Back to Top](#)View Related Documentation for [Digital Logic](#)

- [Logic Reference Guide](#) (SCYB004, 1032 KB - Updated: 10/23/2001)
- [Logic Selection Guide Second Half 2002 \(Rev. R\)](#) (SDYU001R, 4274 KB - Updated: 07/19/2002)
- [Military Semiconductors Selection Guide 2002 \(Rev. B\)](#) (SGYC003B, 1648 KB - Updated: 04/22/2002)

PRICING/AVAILABILITY/PKG[▲Back to Top](#)

DEVICE INFORMATION							TI INVENTORY STATUS AS OF 3:00 PM GMT, 26 Sep 2002			REPORTED DISTRIBUTOR INVENTORY AS OF 3:00 PM GMT, 26 Sep 2002		
ORDERABLE DEVICE	STATUS	PACKAGE TYPE PINS	TEMP (°C)	PRODUCT CONTENT	BUDGETARY PRICING QTY SUS	STD PACK QTY	IN STOCK	IN PROGRESS QTY DATE	LEAD TIME	DISTRIBUTOR COMPANY REGION	IN STOCK	PURCHASE
SN74LS151D	ACTIVE	SOP (D) 16	0 TO 70	View Contents	1KU 0.34	40	N/A*		12 WKS			
SN74LS151DR	ACTIVE	SOP (D) 16	0 TO 70	View Contents	1KU 0.36	2500	N/A*		12 WKS			
SN74LS151J	OBSOLETE	CDIP (J) 16	0 TO 70	View Contents	1KU		N/A*		Not Available			
SN74LS151N	ACTIVE	PDIP (N) 16	0 TO 70	View Contents	1KU 0.27	25	N/A*		16 WKS			
SN74LS151N3	OBSOLETE	PDIP (N) 16	0 TO 70	View Contents	1KU		N/A*		Not Available			
SN74LS151NSR	ACTIVE	SOP (NS) 16		View Contents	1KU 0.27	2000	N/A*		12 WKS			

Table Data Updated on: 9/26/2002

