

TC74HCT245AP, TC74HCT245AF, TC74HCT245AFW

OCTAL BUS TRANSCEIVER (3-STATE)

The TC74HCT245A is high speed CMOS OCTAL BUS TRANSCEIVER fabricated with silicon gate C²MOS technology.

It achieves the high speed operation similar to equivalent LSTTL while maintaining the CMOS low power dissipation. Its inputs are compatible with TTL, NMOS, and CMOS output voltage levels.

It is intended for two - way asynchronous communication between data busses. The direction of data transmission is determined by the level of the DIR input.

The enable input (\bar{G}) can be used to disable the device so that the busses are effectively isolated.

All inputs are equipped with protection circuits against static discharge or transient excess voltage.

FEATURES :

- High Speed..... $t_{pd} = 10ns(typ.)$ at $V_{CC} = 5V$
- Low Power Dissipation..... $I_{CC} = 4\mu A(Max.)$ at $T_a = 25^\circ C$
- Compatible with TTL outputs.... $V_{IL} = 0.8V(Max.)$
 $V_{IH} = 2.0V(Min.)$
- Wide Interfacing ability..... LSTTL, NMOS, CMOS
- Output Drive Capability..... 15 LSTTL Loads
- Symmetrical Output Impedance... $|I_{OH}| = I_{OL} = 6mA(Min.)$
- Balanced Propagation Delays.... $t_{pLH} \approx t_{pHL}$
- Pin and Function Compatible with 74LS 245

(Note) The JEDEC SOP (FW) is not available in Japan.

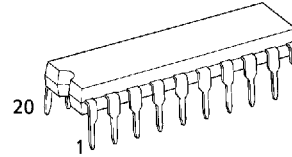

P (DIP20-P-300-2.54A)
Weight : 1.30g (Typ.)

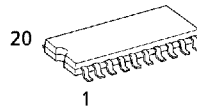

F (SOP20-P-300-1.27)
Weight : 0.22g (Typ.)

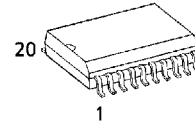

FW (SOL20-P-300-1.27)
Weight : 0.46g (Typ.)

APPLICATION NOTES

- 1) Do not apply a signal to any bus terminal when it is the output mode. Damage may result.
- 2) All floating (high impedance) bus terminals must have their input levels fixed by means of pull up or down resistors.

PIN ASSIGNMENT

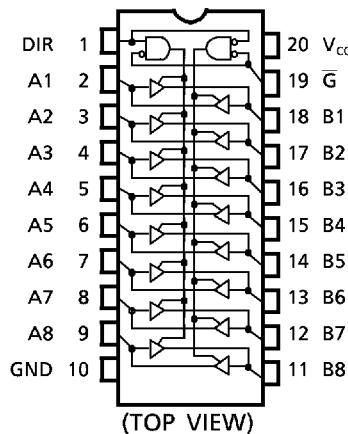

980508EBA2

● TOSHIBA is continually working to improve the quality and the reliability of its products. Nevertheless, semiconductor devices in general can malfunction or fail due to their inherent electrical sensitivity and vulnerability to physical stress. It is the responsibility of the buyer, when utilizing TOSHIBA products, to observe standards of safety, and to avoid situations in which a malfunction or failure of a TOSHIBA product could cause loss of human life, bodily injury or damage to property. In developing your designs, please ensure that TOSHIBA products are used within specified operating ranges as set forth in the most recent products specifications. Also, please keep in mind the precautions and conditions set forth in the TOSHIBA Semiconductor Reliability Handbook.

IEC LOGIC SYMBOL

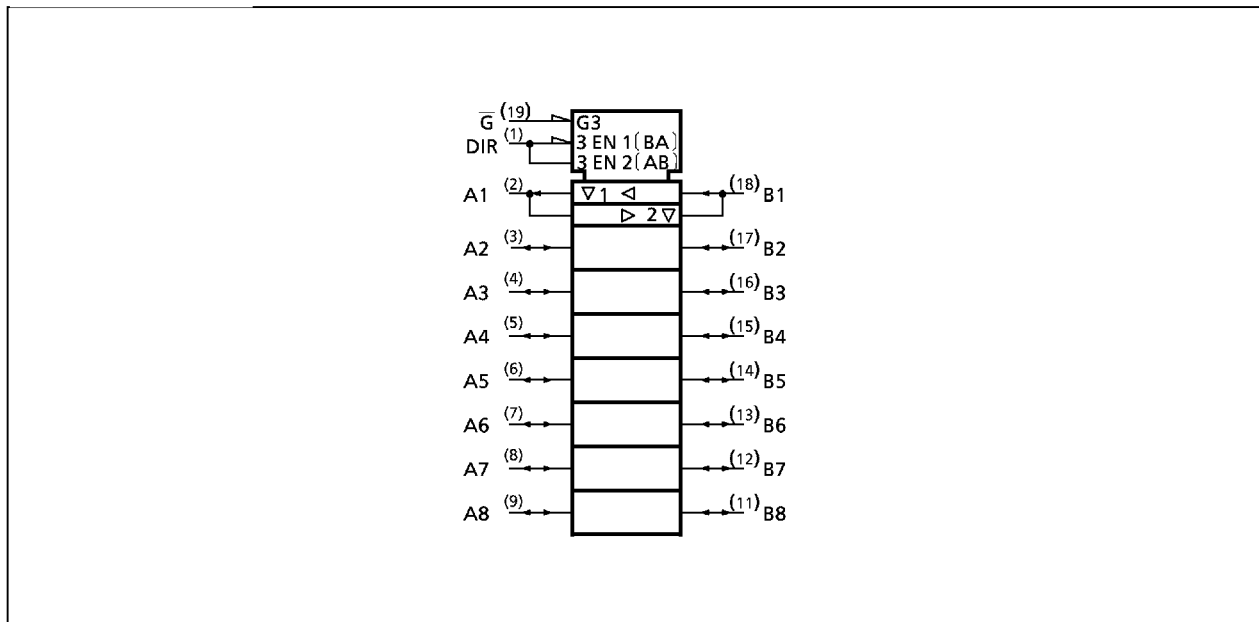

TRUTH TABLE

INPUTS		FUNCTION		OUTPUT
\overline{G}	DIR	A BUS	B BUS	
L	L	OUTPUT	INPUT	A = B
L	H	INPUT	OUTPUT	B = A
H	X	High Impedance		Z

X : "H" or "L"
Z : High Impedance

980508EBA2'

- The products described in this document are subject to foreign exchange and foreign trade laws.
- The information contained herein is presented only as a guide for the applications of our products. No responsibility is assumed by TOSHIBA CORPORATION for any infringements of intellectual property or other rights of the third parties which may result from its use. No license is granted by implication or otherwise under any intellectual property or other rights of TOSHIBA CORPORATION or others.
- The information contained herein is subject to change without notice.

ABSOLUTE MAXIMUM RATINGS

PARAMETER	SYMBOL	VALUE	UNIT
Supply Voltage Range	V_{CC}	-0.5~7	V
DC Input Voltage	V_{IN}	-0.5~ $V_{CC} + 0.5$	V
DC Output Voltage	V_{OUT}	-0.5~ $V_{CC} + 0.5$	V
Input Diode Current	I_{IK}	±20	mA
Output Diode Current	I_{OK}	±20	mA
DC Output Current	I_{OUT}	±35	mA
DC V_{CC} / Ground Current	I_{CC}	±75	mA
Power Dissipation	P_D	500 (DIP)* / 180 (SOP)	mW
Storage Temperature	T_{stg}	-65~150	°C

*500mW in the range of $T_a = -40^{\circ}\text{C} \sim 65^{\circ}\text{C}$. From $T_a = 65^{\circ}\text{C}$ to 85°C a derating factor of $-10\text{mW}/^{\circ}\text{C}$ shall be applied until 300mW.

RECOMMENDED OPERATING CONDITIONS

PARAMETER	SYMBOL	VALUE	UNIT
Supply Voltage	V_{CC}	4.5~5.5	V
Input Voltage	V_{IN}	0~ V_{CC}	V
Output Voltage	V_{OUT}	0~ V_{CC}	V
Operating Temperature	T_{opr}	-40~85	°C
Input Rise and Fall Time	t_r, t_f	0~500	ns

DC ELECTRICAL CHARACTERISTICS

PARAMETER	SYMBOL	TEST CONDITION	V_{CC} (V)	$T_a = 25^{\circ}\text{C}$			$T_a = -40 \sim 85^{\circ}\text{C}$		UNIT	
				MIN.	TYP.	MAX.	MIN.	MAX.		
High - Level Input Voltage	V_{IH}		4.5 5.5	2.0	—	—	2.0	—	V	
Low - Level Input Voltage	V_{IL}		4.5 5.5	—	—	0.8	—	0.8	V	
High - Level Output Voltage	V_{OH}	$V_{IN} = V_{IH}$ or V_{IL}	$I_{OH} = -20 \mu\text{A}$	4.5	4.4	4.5	—	4.4	—	V
			$I_{OH} = -6 \text{ mA}$	4.5	4.18	4.31	—	4.13	—	
Low - Level Output Voltage	V_{OL}	$V_{IN} = V_{IH}$ or V_{IL}	$I_{OL} = 20 \mu\text{A}$	4.5	—	0.0	0.1	—	0.1	V
			$I_{OL} = 6 \text{ mA}$	4.5	—	0.17	0.26	—	0.33	
3 - State Output Off - State Current	I_{OZ}	$V_{IN} = V_{IH}$ or V_{IL} $V_{OUT} = V_{CC}$ or GND	5.5	—	—	±0.5	—	±5.0	μA	
Input Leakage Current	I_{IN}	$V_{IN} = V_{CC}$ or GND	5.5	—	—	±0.1	—	±1.0		
Quiescent Supply Current	I_{CC}	$V_{IN} = V_{CC}$ or GND	5.5	—	—	4.0	—	40.0		
	I_C	Per input: $V_{IN} = 0.5\text{V}$ or 2.4V Other input: V_{CC} or GND	5.5	—	—	2.0	—	2.9	mA	

AC ELECTRICAL CHARACTERISTICS (Input $t_r = t_f = 6\text{ns}$)

PARAMETER	SYMBOL	TEST CONDITION	CL (pF)	V _{CC} (V)	Ta = 25°C			Ta = -40~85°C		UNIT
					MIN.	TYP.	MAX.	MIN.	MAX.	
Output Transition Time	t_{TLH} t_{THL}		50	4.5	—	7	12	—	15	ns
				5.5	—	6	11	—	14	
Propagation Delay Time	t_{pLH} t_{pHL}		50	4.5	—	13	22	—	28	
				5.5	—	11	20	—	25	
			150	4.5	—	18	30	—	38	
				5.5	—	16	27	—	34	
3-State Output Enable time	t_{pZL} t_{pZH}	$R_L = 1\text{k}\Omega$	50	4.5	—	19	30	—	38	
				5.5	—	16	27	—	34	
			150	4.5	—	24	38	—	48	
				5.5	—	22	34	—	43	
3-State Output Disable time	t_{pLZ} t_{pHZ}	$R_L = 1\text{k}\Omega$	50	4.5	—	17	30	—	38	
				5.5	—	16	27	—	34	
Input Capacitance	C_{IN}	$\overline{DIR}, \overline{G}$			—	5	10	—	10	pF
Output Capacitance	C_{VO}	An, Bn			—	13	—	—	—	
Power Dissipation Capacitance	C_{PD}				—	41	—	—	—	

Note(1): C_{PD} is defined as the value of the internal equivalent capacitance which is calculated from the operating current consumption without load.

Average operating current can be obtained by the equation :

$$I_{CC}(\text{opr}) = C_{PD} \cdot V_{CC} \cdot f_{IN} + I_{CC} / 8 \text{ (per bit)}$$

DIP 20PIN OUTLINE DRAWING (DIP20-P-300-2.54A)

Unit in mm

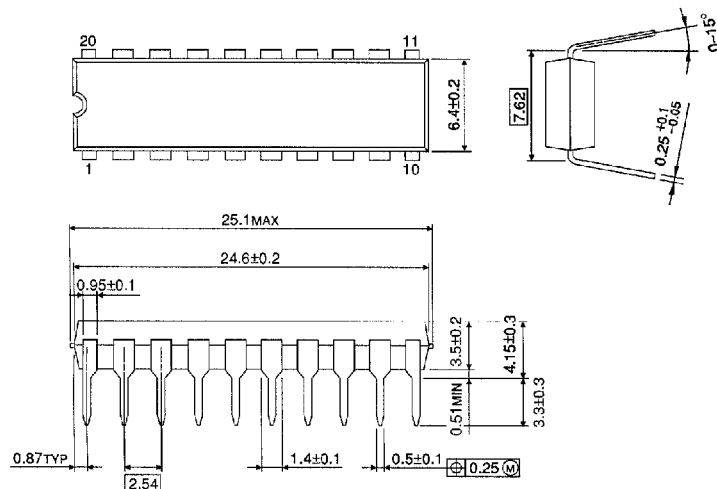

Weight : 1.30g (Typ.)

SOP 20PIN (200mil BODY) OUTLINE DRAWING (SOP20-P-300-1.27)

Unit in mm

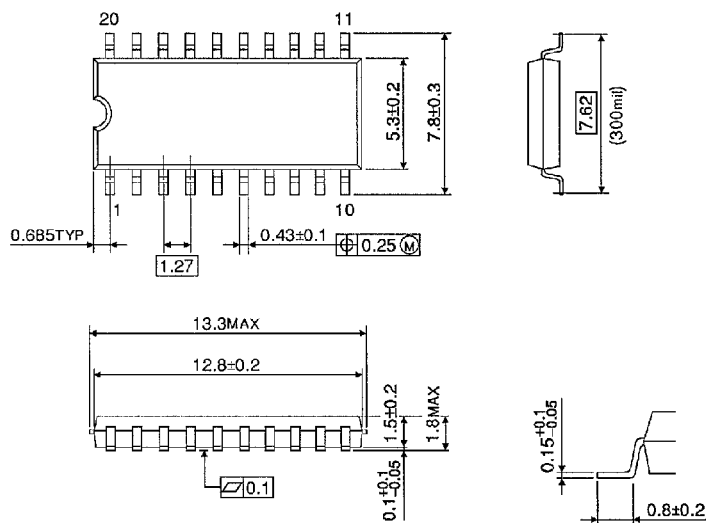

Weight : 0.22g (Typ.)

SOP 20PIN (300mil BODY) OUTLINE DRAWING (SOL20-P-300-1.27)

Unit in mm

(Note) This package is not available in Japan.

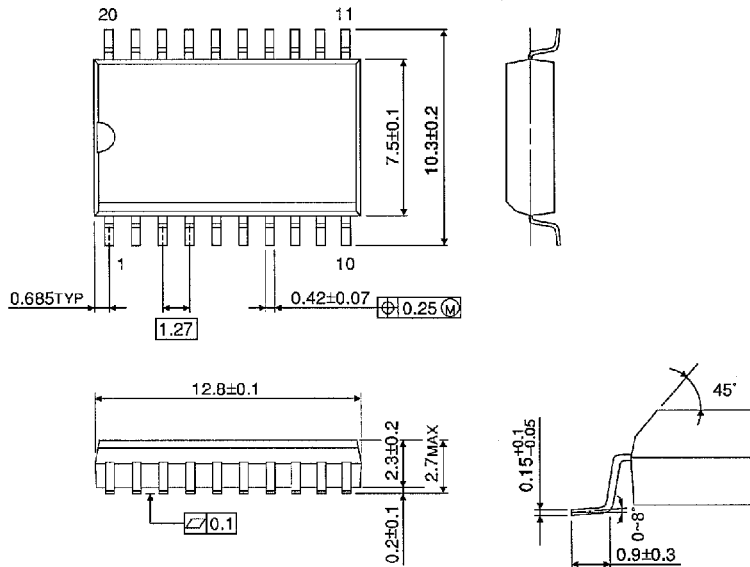

Weight : 0.46g (Typ.)