

DM74LS138, DM74LS139 Decoders/Demultiplexers

General Description

These Schottky-clamped circuits are designed to be used in high-performance memory-decoding or data-routing applications, requiring very short propagation delay times. In high-performance memory systems these decoders can be used to minimize the effects of system decoding. When used with high-speed memories, the delay times of these decoders are usually less than the typical access time of the memory. This means that the effective system delay introduced by the decoder is negligible.

The LS138 decodes one-of-eight lines, based upon the conditions at the three binary select inputs and the three enable inputs. Two active-low and one active-high enable inputs reduce the need for external gates or inverters when expanding. A 24-line decoder can be implemented with no external inverters, and a 32-line decoder requires only one inverter. An enable input can be used as a data input for demultiplexing applications.

The LS139 comprises two separate two-line-to-four-line decoders in a single package. The active-low enable input can be used as a data line in demultiplexing applications.

All of these decoders/demultiplexers feature fully buffered inputs, presenting only one normalized load to its driving circuit.

All inputs are clamped with high-performance Schottky diodes to suppress line-ringing and simplify system design.

Features

- Designed specifically for high speed:
 - Memory decoders
 - Data transmission systems
- LS138 3-to-8-line decoders incorporates 3 enable inputs to simplify cascading and/or data reception
- LS139 contains two fully independent 2-to-4-line decoders/demultiplexers
- Schottky clamped for high performance
- Typical propagation delay (3 levels of logic)
 - LS138 21 ns
 - LS139 21 ns
- Typical power dissipation
 - LS138 32 mW
 - LS139 34 mW
- Alternate Military/Aerospace devices (54LS138, 54LS139) are available. Contact a Fairchild Semiconductor Sales Office/Distributor for specifications.

Connection Diagrams

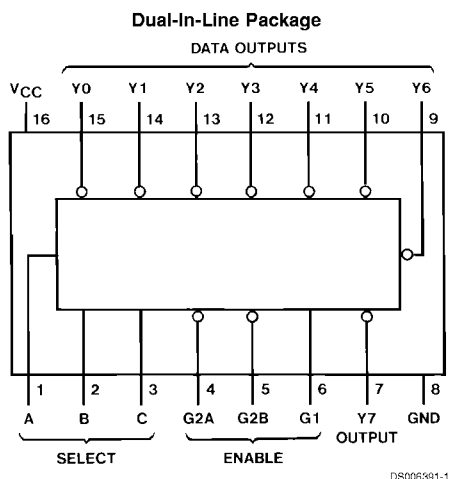

**Order Number 54LS138DMQB, 54LS138FMQB,
54LS138LMQB, DM54LS138J, DM54LS138W,
DM74LS138M or DM74LS138N
See Package Number E20A, J16A,
M16A, N16E or W16A
Dual-In-Line Package**

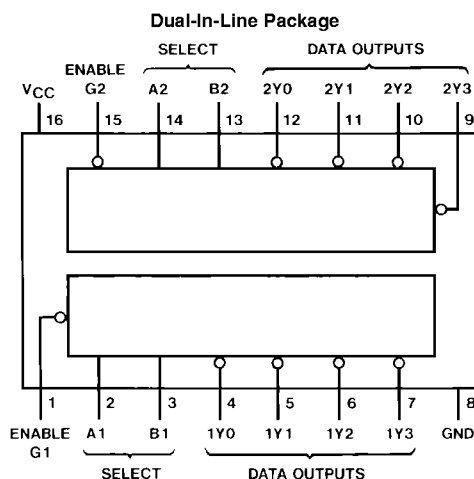

**Order Number 54LS139DMQB, 54LS139FMQB,
54LS139LMQB, DM54LS139J, DM54LS139W,
DM74LS139M or DM74LS139N
See Package Number E20A, J16A,
M16A, N16E or W16A**

Absolute Maximum Ratings (Note 1)	DM54LS and 54LS	-55°C to +125°C
Supply Voltage	7V	DM74LS
Input Voltage	7V	Storage Temperature Range
Operating Free Air Temperature Range		-65°C to +150°C

Recommended Operating Conditions

Symbol	Parameter	DM54LS138			DM74LS138			Units
		Min	Nom	Max	Min	Nom	Max	
V _{CC}	Supply Voltage	4.5	5	5.5	4.75	5	5.25	V
V _{IH}	High Level Input Voltage	2			2			V
V _{IL}	Low Level Input Voltage			0.7			0.8	V
I _{OH}	High Level Output Current			-0.4			-0.4	mA
I _{OL}	Low Level Output Current			4			8	mA
T _A	Free Air Operating Temperature	-55		125	0		70	°C

Note 1: The "Absolute Maximum Ratings" are those values beyond which the safety of the device cannot be guaranteed. The device should not be operated at these limits. The parametric values defined in the "Electrical Characteristics" table are not guaranteed at the absolute maximum ratings. The "Recommended Operating Conditions" table will define the conditions for actual device operation.

'LS138 Electrical Characteristics

over recommended operating free air temperature range (unless otherwise noted)

Symbol	Parameter	Conditions	Min	Typ (Note 2)	Max	Units
V _I	Input Clamp Voltage	V _{CC} = Min, I _I = -18 mA			-1.5	V
V _{OH}	High Level Output Voltage	V _{CC} = Min, I _{OH} = Max, V _{IL} = Max, V _{IH} = Min	DM54 2.5	3.4		V
V _{OL}	Low Level Output Voltage	V _{CC} = Min, I _{OL} = Max, V _{IL} = Max, V _{IH} = Min	DM54 0.25	0.4		V
		I _{OL} = 4 mA, V _{CC} = Min	DM74 0.35	0.5		
I _I	Input Current @ Max Input Voltage	V _{CC} = Max, V _I = 7V			0.1	mA
I _{IH}	High Level Input Current	V _{CC} = Max, V _I = 2.7V			20	µA
I _{IL}	Low Level Input Current	V _{CC} = Max, V _I = 0.4V			-0.36	mA
I _{OS}	Short Circuit Output Current	V _{CC} = Max (Note 3)	DM54 -20		-100	mA
			DM74 -20		-100	
I _{CC}	Supply Current	V _{CC} = Max (Note 4)		6.3	10	mA

Note 2: All typicals are at V_{CC} = 5V, T_A = 25°C.

Note 3: Not more than one output should be shorted at a time, and the duration should not exceed one second.

Note 4: I_{CC} is measured with all outputs enabled and open.

'LS138 Switching Characteristics

at V_{CC} = 5V and T_A = 25°C

Symbol	Parameter	From (Input) To (Output)	Levels of Delay	R _L = 2 kΩ				Units
				C _L = 15 pF		C _L = 50 pF		
				Min	Max	Min	Max	
t _{PLH}	Propagation Delay Time Low to High Level Output	Select to Output	2		18		27	ns
t _{PHL}	Propagation Delay Time High to Low Level Output	Select to Output	2		27		40	ns
t _{PLH}	Propagation Delay Time Low to High Level Output	Select to Output	3		18		27	ns

'LS138 Switching Characteristics (Continued)

at $V_{CC} = 5V$ and $T_A = 25^\circ C$

Symbol	Parameter	From (Input) To (Output)	Levels of Delay	$R_L = 2\text{ k}\Omega$				Units
				$C_L = 15\text{ pF}$		$C_L = 50\text{ pF}$		
				Min	Max	Min	Max	
t_{PHL}	Propagation Delay Time High to Low Level Output	Select to Output	3		27		40	ns
t_{PLH}	Propagation Delay Time Low to High Level Output	Enable to Output	2		18		27	ns
t_{PHL}	Propagation Delay Time High to Low Level Output	Enable to Output	2		24		40	ns
t_{PLH}	Propagation Delay Time Low to High Level Output	Enable to Output	3		18		27	ns
t_{PHL}	Propagation Delay Time High to Low Level Output	Enable to Output	3		28		40	ns

Recommended Operating Conditions

Symbol	Parameter	DM54LS139			DM74LS139			Units
		Min	Nom	Max	Min	Nom	Max	
V_{CC}	Supply Voltage	4.5	5	5.5	4.75	5	5.25	V
V_{IH}	High Level Input Voltage	2			2			V
V_{IL}	Low Level Input Voltage			0.7			0.8	V
I_{OH}	High Level Output Current			-0.4			-0.4	mA
I_{OL}	Low Level Output Current			4			8	mA
T_A	Free Air Operating Temperature	-55		125	0		70	$^\circ C$

'LS139 Electrical Characteristics

over recommended operating free air temperature range (unless otherwise noted)

Symbol	Parameter	Conditions	Min	Typ (Note 5)	Max	Units	
V_I	Input Clamp Voltage	$V_{CC} = \text{Min}, I_I = -18\text{ mA}$			-1.5	V	
V_{OH}	High Level Output Voltage	$V_{CC} = \text{Min}, I_{OH} = \text{Max},$ $V_{IL} = \text{Max}, V_{IH} = \text{Min}$	DM54	2.5	3.4	V	
			DM74	2.7	3.4		
V_{OL}	Low Level Output Voltage	$V_{CC} = \text{Min}, I_{OL} = \text{Max}$ $V_{IL} = \text{Max}, V_{IH} = \text{Min}$ $I_{OL} = 4\text{ mA}, V_{CC} = \text{Min}$	DM54		0.25	0.4	V
			DM74		0.35	0.5	
			DM74		0.25	0.4	
I_I	Input Current @ Max Input Voltage	$V_{CC} = \text{Max}, V_I = 7V$			0.1	mA	
I_{IH}	High Level Input Current	$V_{CC} = \text{Max}, V_I = 2.7V$			20	μA	
I_{IL}	Low Level Input Current	$V_{CC} = \text{Max}, V_I = 0.4V$			-0.36	mA	
I_{OS}	Short Circuit Output Current	$V_{CC} = \text{Max}$ (Note 6)	DM54	-20		-100	mA
			DM74	-20		-100	
I_{CC}	Supply Current	$V_{CC} = \text{Max}$ (Note 7)		6.8	11	mA	

Note 5: All typicals are at $V_{CC} = 5V, T_A = 25^\circ C$.

Note 6: Not more than one output should be shorted at a time, and the duration should not exceed one second.

Note 7: I_{CC} is measured with all outputs enabled and open.

'LS139 Switching Characteristics

at $V_{CC} = 5V$ and $T_A = 25^\circ C$

Symbol	Parameter	From (Input) To (Output)	$R_L = 2\text{ k}\Omega$				Units
			$C_L = 15\text{ pF}$		$C_L = 50\text{ pF}$		
			Min	Max	Min	Max	
t_{PLH}	Propagation Delay Time Low to High Level Output	Select to Output		18		27	ns
t_{PHL}	Propagation Delay Time High to Low Level Output	Select to Output		27		40	ns
t_{PLH}	Propagation Delay Time Low to High Level Output	Enable to Output		18		27	ns
t_{PHL}	Propagation Delay Time High to Low Level Output	Enable to Output		24		40	ns

Function Tables LS138

Inputs				Outputs								
Enable		Select										
G1	G2 (Note 8)	C	B	A	Y0	Y1	Y2	Y3	Y4	Y5	Y6	Y7
X	H	X	X	X	H	H	H	H	H	H	H	H
L	X	X	X	X	H	H	H	H	H	H	H	H
H	L	L	L	L	L	H	H	H	H	H	H	H
H	L	L	L	H	H	L	H	H	H	H	H	H
H	L	L	H	L	H	H	L	H	H	H	H	H
H	L	L	H	H	H	H	H	L	H	H	H	H
H	L	H	L	L	H	H	H	H	L	H	H	H
H	L	H	L	H	H	H	H	H	H	L	H	H
H	L	H	H	L	H	H	H	H	H	H	L	H
H	L	H	H	H	H	H	H	H	H	H	H	L

H = High Level, L = Low Level, X = Don't Care

Note 8: $G2 = G2A + G2B$

LS139

Inputs			Outputs			
Enable	Select					
G	B	A	Y0	Y1	Y2	Y3
H	X	X	H	H	H	H
L	L	L	L	H	H	H
L	L	H	H	L	H	H
L	H	L	H	H	L	H
L	H	H	H	H	H	L

H = High Level, L = Low Level, X = Don't Care

Logic Diagrams

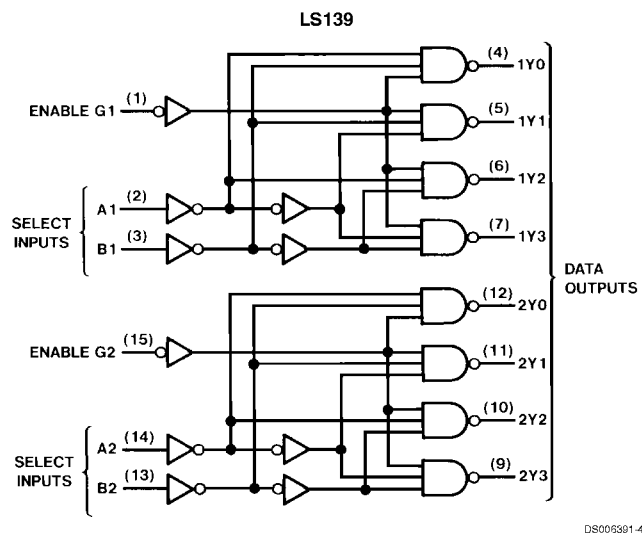
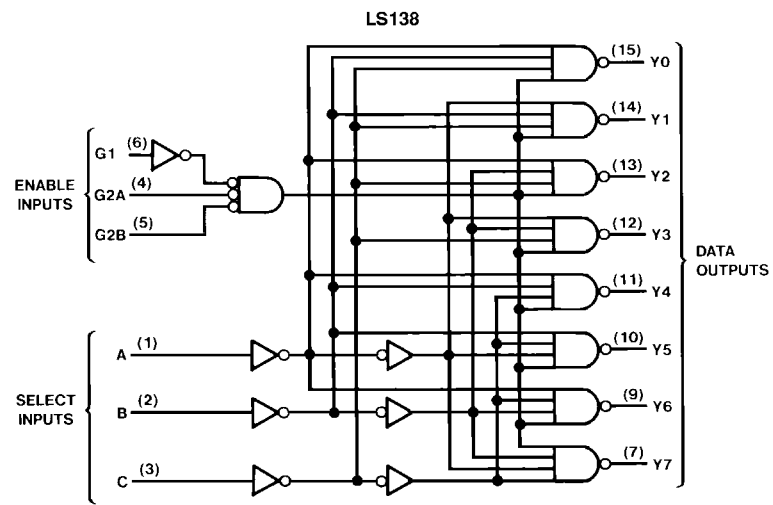

Physical Dimensions inches (millimeters) unless otherwise noted

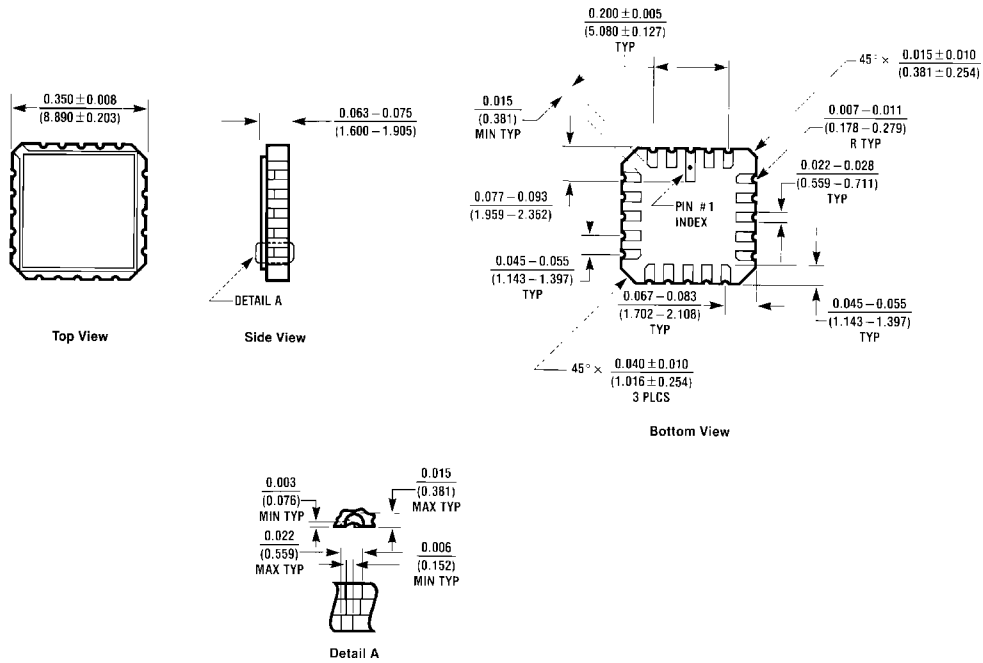

Ceramic Leadless Chip Carrier Package (E)
Order Number 54LS138LMQB or 54LS139LMQB
Package Number E20A

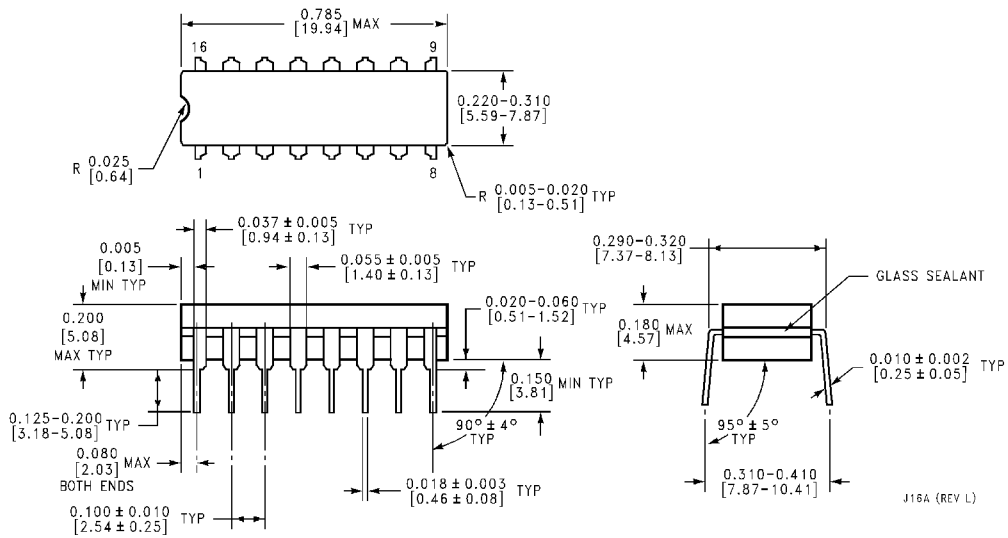

16-Lead Ceramic Dual-In-Line Package (J)
Order Number 54LS138DMQB, 54LS139DMQB, DM54LS138J or DM54LS139J
Package Number J16A

Physical Dimensions inches (millimeters) unless otherwise noted (Continued)

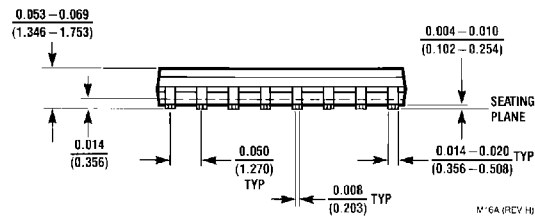
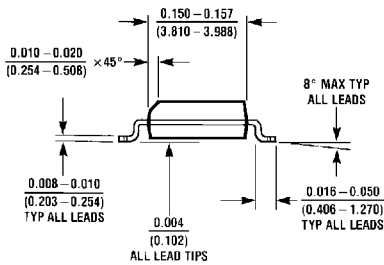
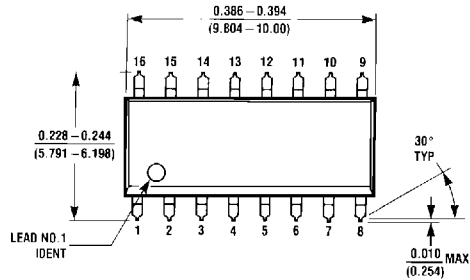

16-Lead Small Outline Molded Package (M)
Order Number DM74LS138M or DM74LS139M
Package Number M16A

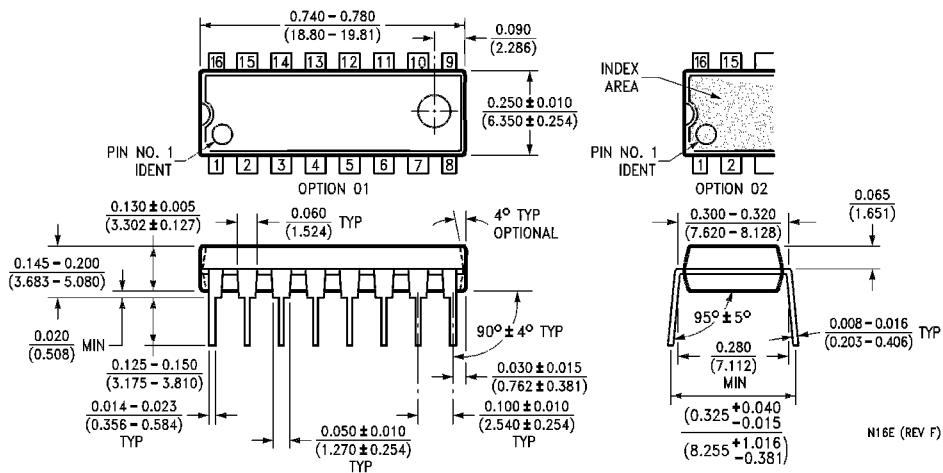

16-Lead Molded Dual-In-Line Package (N)
Order Number DM74LS138N or DM74LS139N
Package Number N16E

Physical Dimensions inches (millimeters) unless otherwise noted (Continued)

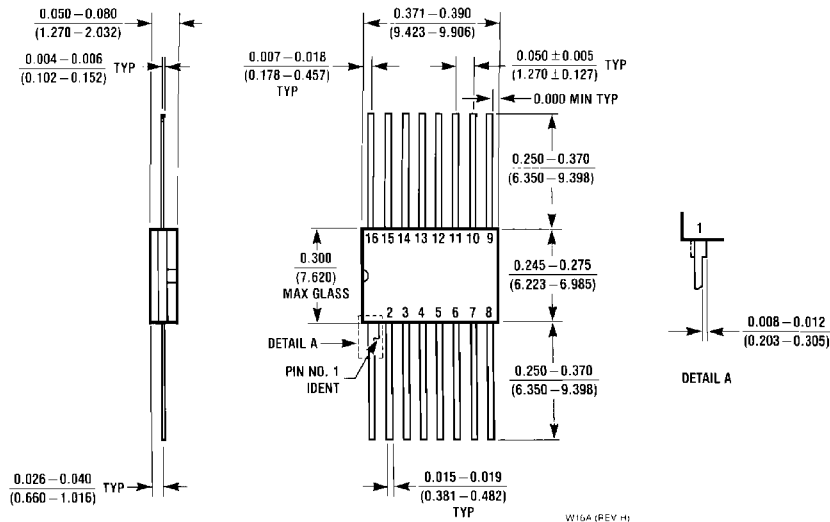

16-Lead Ceramic Flat Package (W)
Order Number 54LS138FMQB, 54LS139FMQB, DM54LS138W or DM54LS139W
Package Number W16A

LIFE SUPPORT POLICY

FAIRCHILD'S PRODUCTS ARE NOT AUTHORIZED FOR USE AS CRITICAL COMPONENTS IN LIFE SUPPORT DEVICES OR SYSTEMS WITHOUT THE EXPRESS WRITTEN APPROVAL OF THE PRESIDENT OF FAIRCHILD SEMICONDUCTOR CORPORATION. As used herein:

1. Life support devices or systems are devices or systems which, (a) are intended for surgical implant into the body, or (b) support or sustain life, and (c) whose failure to perform when properly used in accordance with instructions for use provided in the labeling, can be reasonably expected to result in a significant injury to the user.
2. A critical component in any component of a life support device or system whose failure to perform can be reasonably expected to cause the failure of the life support device or system, or to affect its safety or effectiveness.

Fairchild Semiconductor Corporation Americas
 Customer Response Center
 Tel: 1-888-522-5372

Fairchild Semiconductor Europe
 Fax: +49 (0) 1 80-530 85 86
 Email: europe.support@nsc.com
 Deutsch Tel: +49 (0) 8 141-35-0
 English Tel: +44 (0) 1 793-85-68-56
 Italy Tel: +39 (0) 2 57 5631

Fairchild Semiconductor Hong Kong Ltd.
 13th Floor, Straight Block,
 Ocean Centre, 5 Canton Rd.
 Tsimshatsui, Kowloon
 Hong Kong
 Tel: +852 2737-7200
 Fax: +852 2314-0061

National Semiconductor Japan Ltd.
 Tel: 81-3-5620-6175
 Fax: 81-3-5620-6179

www.fairchildsemi.com