

TOSHIBA TRANSISTOR SILICON NPN EPITAXIAL PLANAR TYPE

2SC4844

VHF~UHF BAND LOW NOISE AMPLIFIER APPLICATIONS.

Unit in mm

- Low Noise Figure, High Gain.
- $NF = 1.8\text{dB}$, $|S_{21e}|^2 = 9.5\text{dB}$ ($f = 2\text{GHz}$)

MAXIMUM RATINGS ($T_a = 25^\circ\text{C}$)

CHARACTERISTIC	SYMBOL	RATING	UNIT
Collector-Base Voltage	V_{CB0}	20	V
Collector-Emitter Voltage	V_{CE0}	10	V
Emitter-Base Voltage	V_{EB0}	1.5	V
Base Current	I_B	7	mA
Collector Current	I_C	15	mA
Collector Power Dissipation	P_C	100	mW
Junction Temperature	T_j	125	$^\circ\text{C}$
Storage Temperature Range	T_{stg}	-55~125	$^\circ\text{C}$

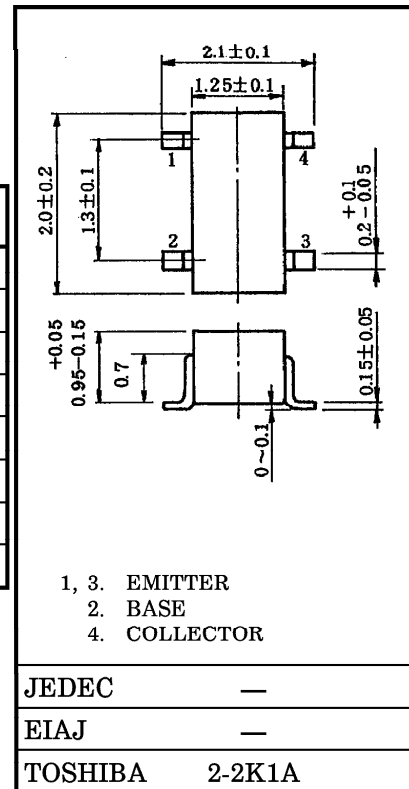

Weight : 0.006g

Marking

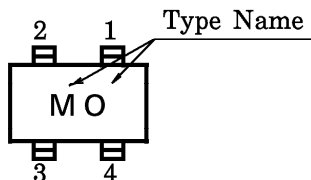

MICROWAVE CHARACTERISTICS ($T_a = 25^\circ\text{C}$)

CHARACTERISTIC	SYMBOL	TEST CONDITION	MIN.	TYP.	MAX.	UNIT
Transition Frequency	f_T	$V_{CE} = 6\text{V}$, $I_C = 7\text{mA}$	7	10	—	GHz
Insertion Gain	$ S_{21e} ^2$ (1)	$V_{CE} = 6\text{V}$, $I_C = 7\text{mA}$, $f = 1\text{GHz}$	—	15	—	dB
	$ S_{21e} ^2$ (2)	$V_{CE} = 6\text{V}$, $I_C = 7\text{mA}$, $f = 2\text{GHz}$	6.5	9.5	—	
Noise Figure	NF (1)	$V_{CE} = 6\text{V}$, $I_C = 3\text{mA}$, $f = 1\text{GHz}$	—	1.4	—	dB
	NF (2)	$V_{CE} = 6\text{V}$, $I_C = 3\text{mA}$, $f = 2\text{GHz}$	—	1.8	3.0	

ELECTRICAL CHARACTERISTICS ($T_a = 25^\circ\text{C}$)

CHARACTERISTIC	SYMBOL	TEST CONDITION	MIN.	TYP.	MAX.	UNIT
Collector Cut-off Current	I_{CBO}	$V_{CB} = 10\text{V}$, $I_E = 0$	—	—	1	μA
Emitter Cut-off Current	I_{EBO}	$V_{EB} = 1\text{V}$, $I_C = 0$	—	—	1	μA
DC Current Gain	h_{FE}	$V_{CE} = 6\text{V}$, $I_C = 7\text{mA}$	50	—	250	—
Output Capacitance	C_{ob}	$V_{CB} = 10\text{V}$, $I_E = 0$, $f = 1\text{MHz}$	—	0.55	—	pF
Reverse Transfer Capacitance	C_{re}	(Note)	—	0.35	0.8	pF

Note : C_{re} is measured by 3 terminal method with capacitance bridge.

961001EAA2

● TOSHIBA is continually working to improve the quality and the reliability of its products. Nevertheless, semiconductor devices in general can malfunction or fail due to their inherent electrical sensitivity and vulnerability to physical stress. It is the responsibility of the buyer, when utilizing TOSHIBA products, to observe standards of safety, and to avoid situations in which a malfunction or failure of a TOSHIBA product could cause loss of human life, bodily injury or damage to property. In developing your designs, please ensure that TOSHIBA products are used within specified operating ranges as set forth in the most recent products specifications. Also, please keep in mind the precautions and conditions set forth in the TOSHIBA Semiconductor Reliability Handbook.

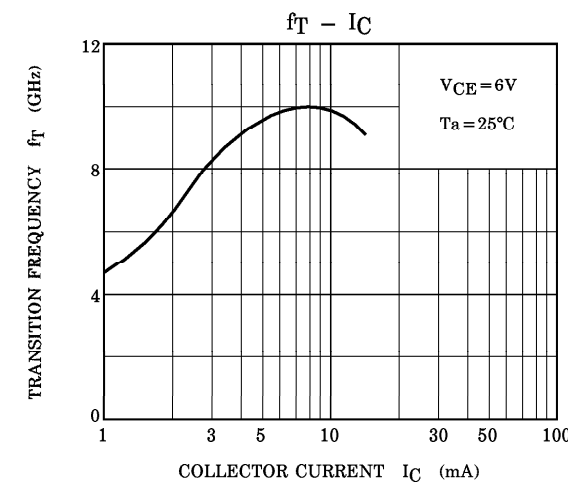
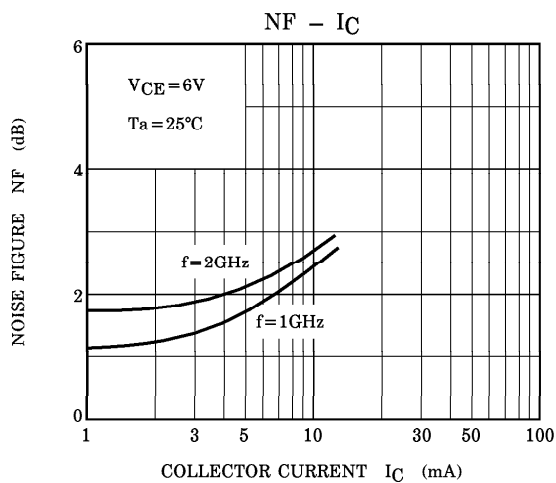
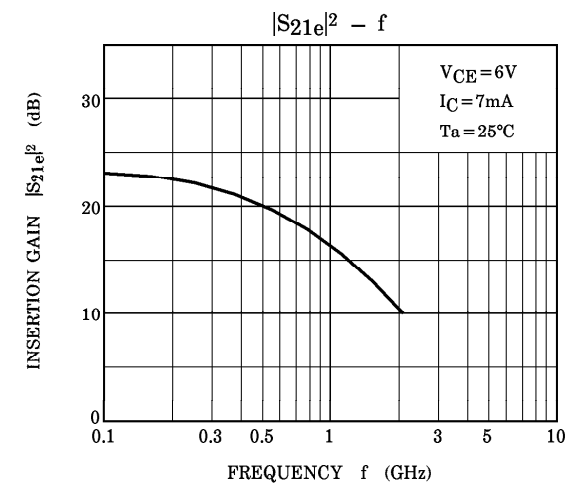
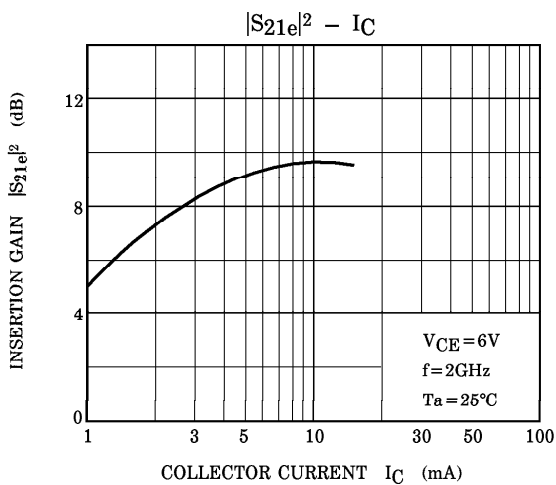
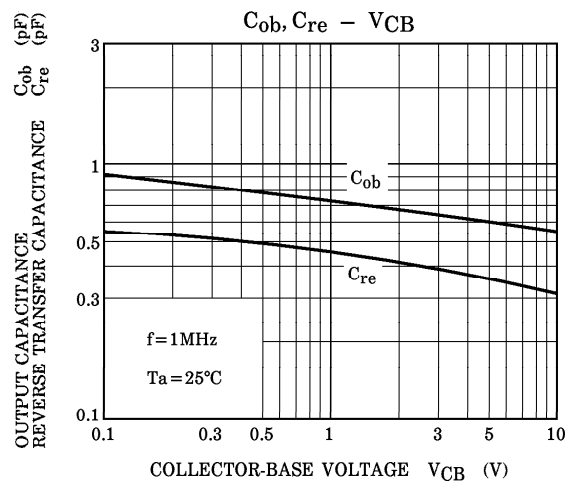
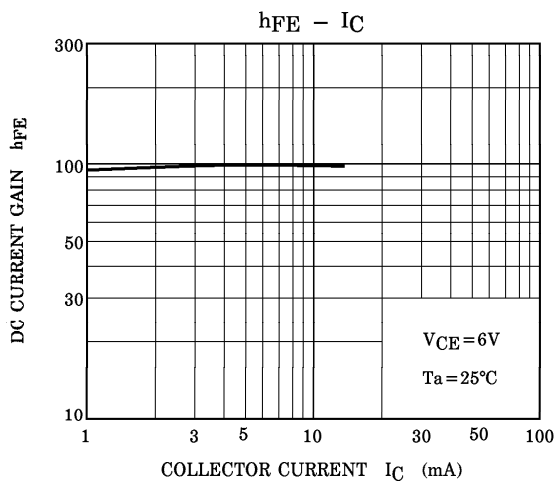

961001EAA2'

● The information contained herein is presented only as a guide for the applications of our products. No responsibility is assumed by TOSHIBA CORPORATION for any infringements of intellectual property or other rights of the third parties which may result from its use. No license is granted by implication or otherwise under any intellectual property or other rights of TOSHIBA CORPORATION or others.
● The information contained herein is subject to change without notice.

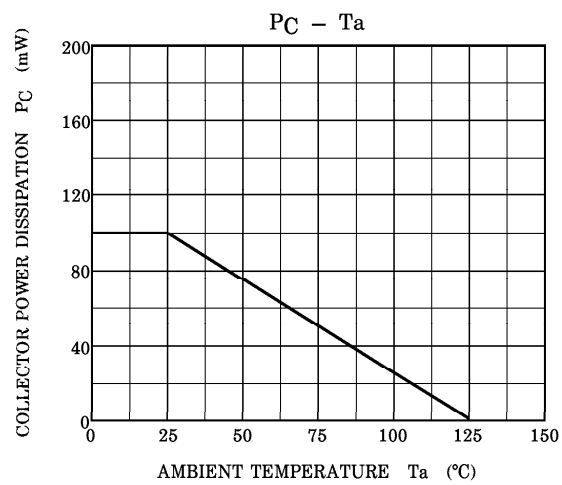
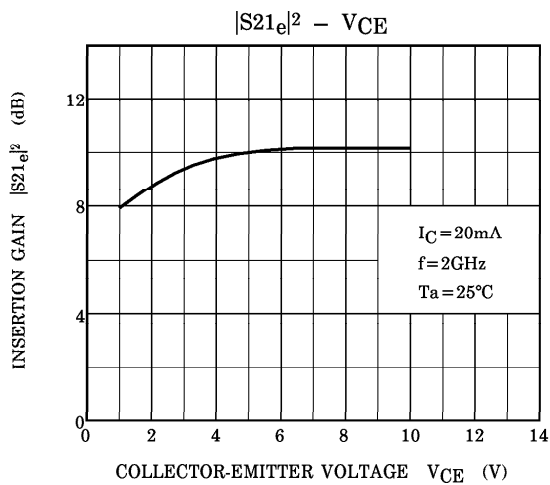

S-PARAMETER Z_O = 50Ω, Ta = 25°C
V_{CE} = 6V, I_C = 3mA

FREQUENCY MHz	S11		S21		S12		S22	
	MAG	ANG	MAG	ANG	MAG	ANG	MAG	ANG
200	0.847	-22.2	7.290	159.9	0.037	75.5	0.954	-16.2
400	0.767	-43.8	6.718	143.8	0.066	64.5	0.857	-29.3
600	0.666	-63.7	6.064	129.8	0.087	56.5	0.765	-39.3
800	0.573	-80.8	5.332	119.0	0.102	51.3	0.680	-47.0
1000	0.492	-96.6	4.642	109.6	0.113	47.5	0.612	-53.3
1200	0.435	-111.0	4.133	102.7	0.121	45.1	0.560	-58.2
1400	0.393	-122.1	3.671	96.6	0.126	44.0	0.518	-62.6
1600	0.366	-132.7	3.314	92.1	0.131	43.5	0.486	-66.5
1800	0.351	-141.5	3.051	88.0	0.136	43.4	0.466	-70.2
2000	0.340	-149.6	2.820	83.7	0.141	43.8	0.450	-73.2

V_{CE} = 6V, I_C = 7mA

FREQUENCY MHz	S11		S21		S12		S22	
	MAG	ANG	MAG	ANG	MAG	ANG	MAG	ANG
200	0.708	-36.8	13.239	151.4	0.032	70.2	0.890	-23.8
400	0.582	-69.7	11.041	131.1	0.053	59.2	0.718	-39.1
600	0.491	-96.0	8.920	116.6	0.066	54.3	0.589	-48.1
800	0.425	-116.4	7.290	107.1	0.074	52.7	0.502	-53.8
1000	0.386	-133.3	6.049	99.4	0.082	52.7	0.442	-58.0
1200	0.368	-147.0	5.176	94.3	0.090	53.5	0.405	-61.3
1400	0.353	-157.1	4.527	89.3	0.097	54.5	0.378	-64.7
1600	0.347	-166.1	4.007	85.7	0.105	55.7	0.359	-67.9
1800	0.345	-172.9	3.634	82.2	0.113	56.7	0.347	-70.7
2000	0.344	-179.0	3.333	78.8	0.120	57.9	0.340	-74.1

S_{11e}
 V_{CE}=6V
 I_C=3mA
 T_a=25°C
 (UNIT : Ω)

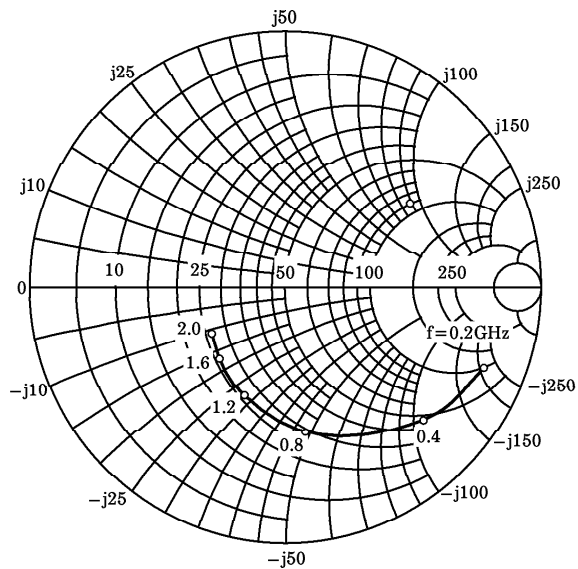

S_{21e}
 V_{CE}=6V
 I_C=3mA
 T_a=25°C

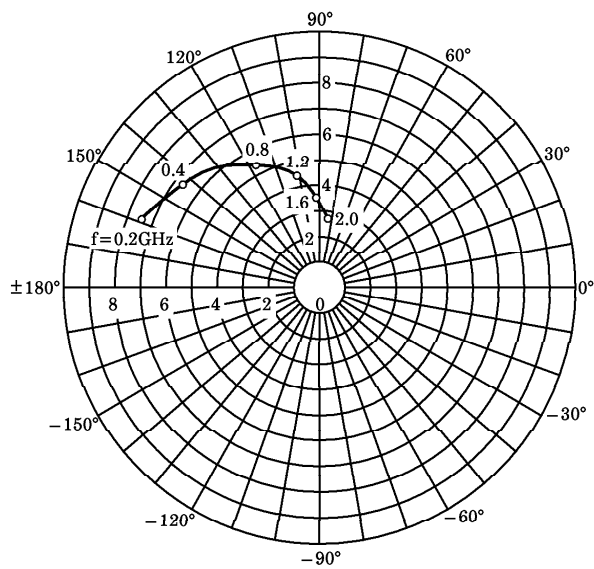

S_{12e}
 V_{CE}=6V
 I_C=3mA
 T_a=25°C

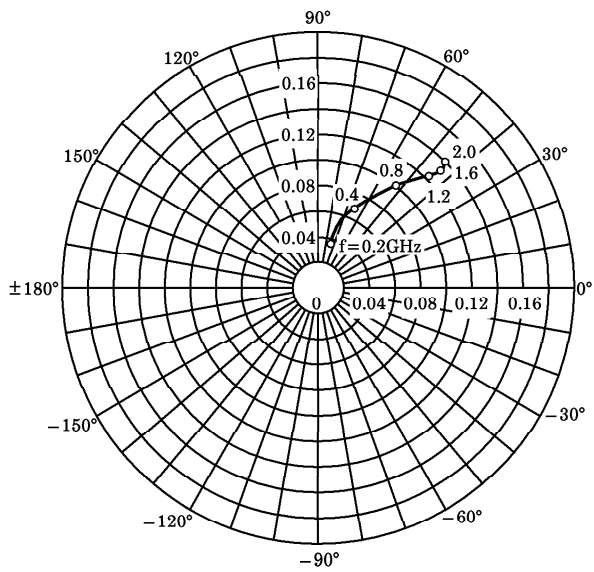

S_{22e}
 V_{CE}=6V
 I_C=3mA
 T_a=25°C
 (UNIT : Ω)

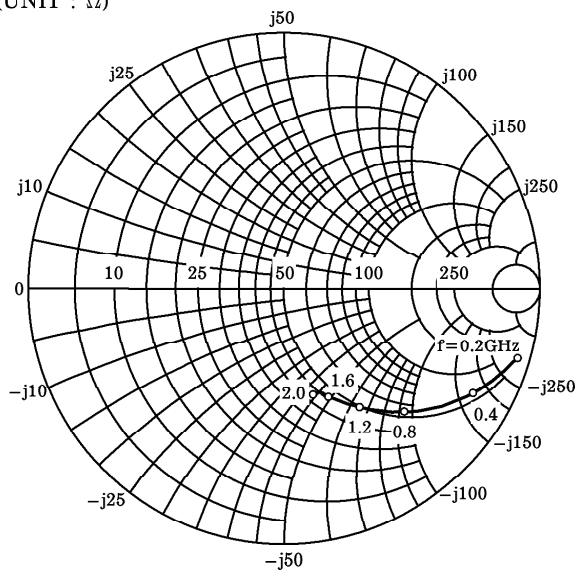

S_{11e}
 V_{CE}=6V
 I_C=7mA
 T_a=25°C
 (単位 : Ω)

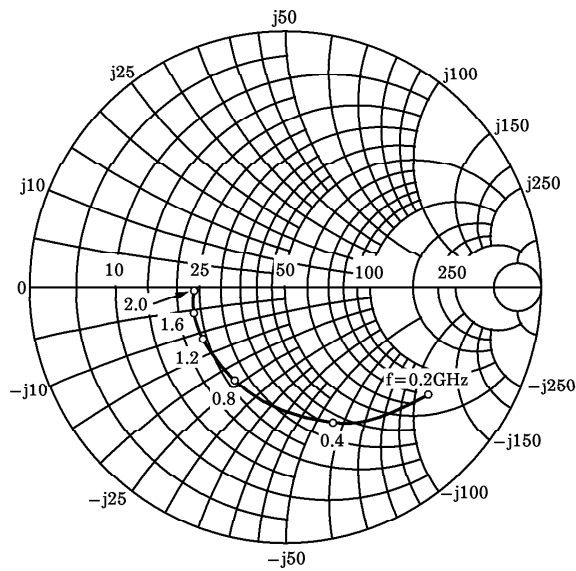

S_{21e}
 V_{CE}=6V
 I_C=7mA
 T_a=25°C

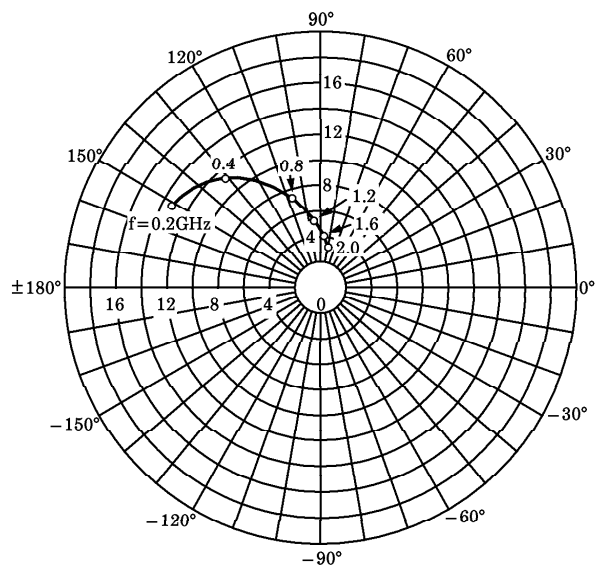

S_{12e}
 V_{CE}=6V
 I_C=7mA
 T_a=25°C

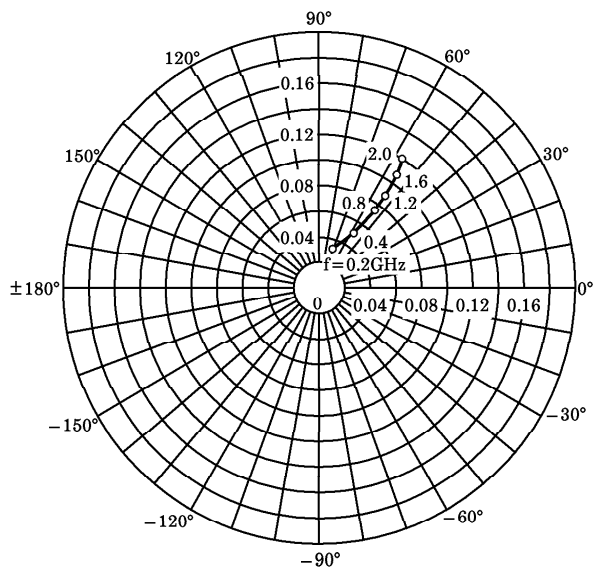

S_{22e}
 V_{CE}=6V
 I_C=7mA
 T_a=25°C
 (単位 : Ω)

