

Features

- ✧ Plastic material used carriers Underwriters Laboratory Classification 94V-0
- ✧ Metal silicon junction, majority carrier conduction
- ✧ Low power loss, high efficiency
- ✧ High current capability, low forward voltage drop
- ✧ High surge capability
- ✧ For use in low voltage - high frequency inverters, free wheeling, and polarity protection applications
- ✧ Guard-ring for overvoltage protection
- ✧ High temperature soldering guaranteed: 260°C/10 seconds, 0.25", (6.35mm) from case
- ✧ Green compound with suffix "G" on packing code & prefix "G" on datecode



Mechanical Data

- ✧ Cases: JEDEC TO-220AB molded plastic
- ✧ Terminals: Pure tin plated, lead free, solderable per MIL-STD-750, Method 2026
- ✧ Polarity: As marked
- ✧ Mounting position: Any
- ✧ Mounting torque: 5 in- lbs, max
- ✧ Weight: 1.90 grams

Ordering Information(example)

Part No.	Package	Packing	Packing code	Green Compound Packing code
MBR3035CT	TO-220AB	50 / TUBE	D0	D0G

Maximum Ratings and Electrical Characteristics

Rating at 25 °C ambient temperature unless otherwise specified.

Single phase, half wave, 60 Hz, resistive or inductive load.

For capacitive load, derate current by 20%

Type Number	Symbol	MBR 3035 CT	MBR 3045 CT	MBR 3050 CT	MBR 3060 CT	MBR 3090 CT	MBR 30100 CT	MBR 30150 CT	Units	
Maximum Recurrent Peak Reverse Voltage	V_{RRM}	35	45	50	60	90	100	150	V	
Maximum RMS Voltage	V_{RMS}	24	31	35	42	63	70	105	V	
Maximum DC Blocking Voltage	V_{DC}	35	45	50	60	90	100	150	V	
Maximum Average Forward Rectified Current	$I_{F(AV)}$	30							A	
Peak Repetitive Forward Current (Rated V_R , Square Wave, 20KHz)	I_{FRM}	30							A	
Peak Forward Surge Current, 8.3 ms Single Half Sine-wave Superimposed on Rated Load (JEDEC method)	I_{FSM}	200							A	
Peak Repetitive Reverse Surge Current (Note 1)	I_{RRM}	1.0			0.5				A	
Maximum Instantaneous Forward Voltage at (Note 2) IF=15A, $T_A=25^\circ C$ IF=15A, $T_A=125^\circ C$ IF=30A, $T_A=25^\circ C$ IF=30A, $T_A=125^\circ C$	V_F	0.7 0.6 0.82 0.73		0.77 0.67 -		0.84 0.70 0.94 0.82		0.95 0.92 1.02 0.98	V	
Maximum Instantaneous Reverse Current @ $T_A=25^\circ C$ at Rated DC Blocking Voltage Per Leg @ $T_A=125^\circ C$	I_R	0.2 15		0.2 10		0.2 7.5		0.1 5	mA mA	
Voltage Rate of Change, (Rated V_R)	dV/dt	10,000							V/us	
Typical Junction Capacitance @4V 1.0MHz	C_j	600		460		320			pF	
Maximum Thermal Resistance Per Leg	$R_{\theta JC}$	1.0				1.5				$^\circ C/W$
Operating Junction Temperature Range	T_J	- 65 to + 150							$^\circ C$	
Storage Temperature Range	T_{STG}	- 65 to + 175							$^\circ C$	

Note 1: 2.0uS Pulse Width, f=1.0KHz

Note 2: Pulse Test : 300us Pulse Width, 1% Duty Cycle

RATINGS AND CHARACTERISTIC CURVES (MBR3035CT THRU MBR30150CT)

FIG. 1- FORWARD CURRENT DERATING CURVE

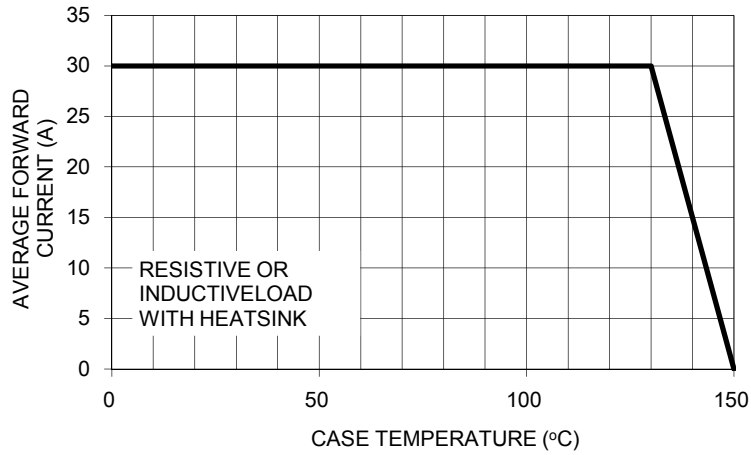

FIG. 2- MAXIMUM NON-REPETITIVE FORWARD SURGE CURRENT PER LEG

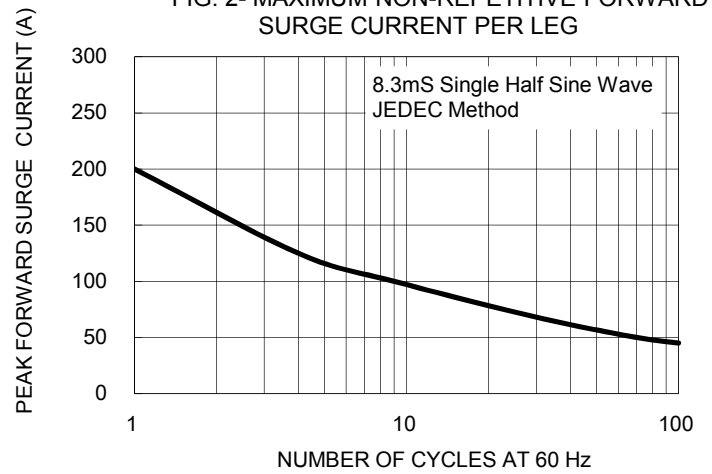

FIG. 3- TYPICAL INSTANTANEOUS FORWARD CHARACTERISTICS PER LEG

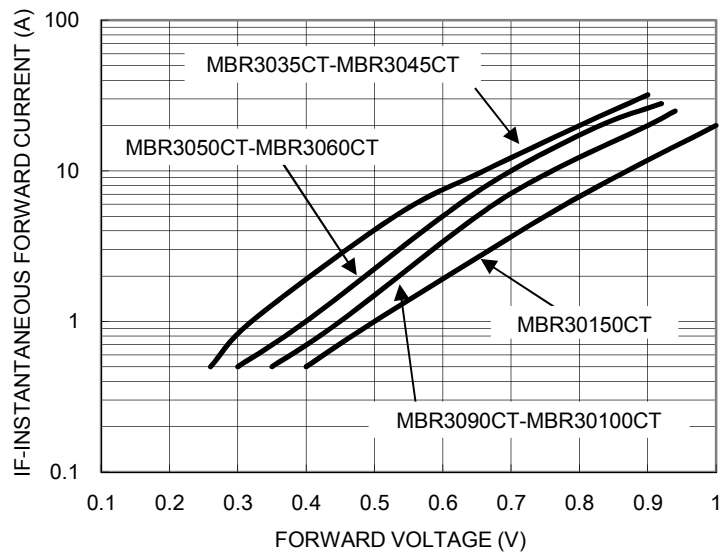

FIG. 4- TYPICAL REVERSE CHARACTERISTICS PER LEG

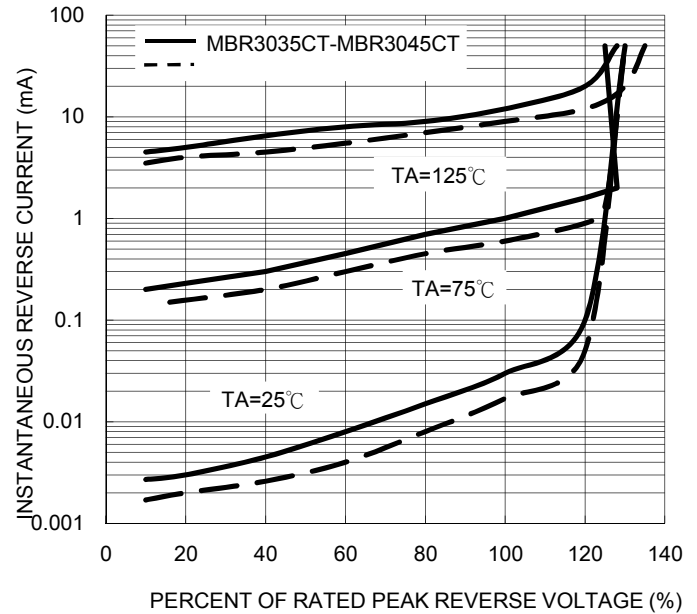

FIG. 5- TYPICAL JUNCTION CAPACITANCE PER LEG

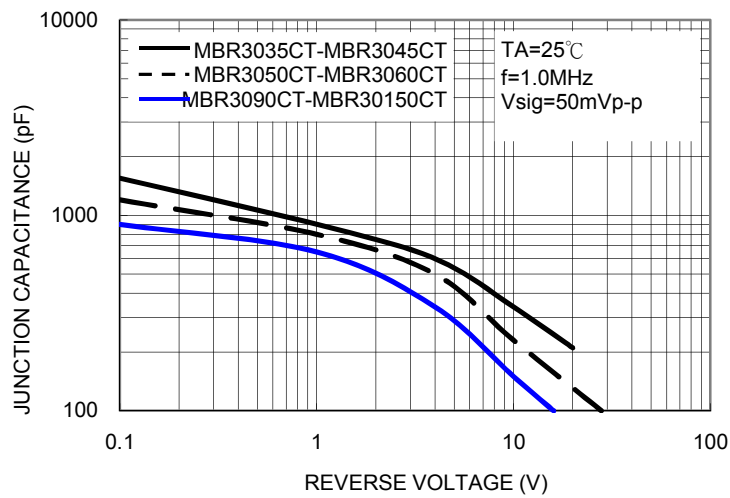
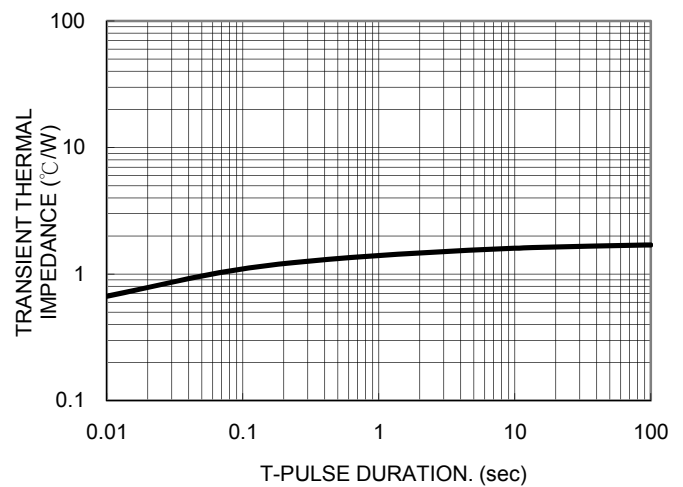

FIG. 6- TYPICAL TRANSIENT THERMAL IMPEDANCE PER LEG



Ordering information

Part No.	Package	BULK Packing	Packing code	Green Compound Packing code
MBR30xxCT	TO-220AB	50 / TUBE	C0	C0G
	TO-220AB	50 / TUBE	D0	D0G

Note: "xx" is Device Code from "35" thru "150".

Dimensions

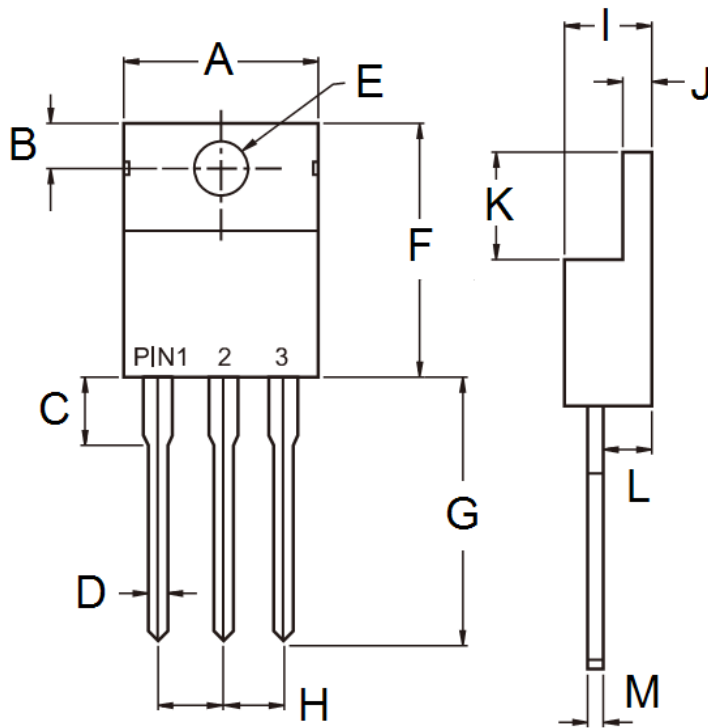

DIM.	Unit(mm)		Unit(inch)	
	Min	Max	Min	Max
A	-	10.50	-	0.413
B	2.62	3.44	0.103	0.135
C	2.80	4.20	0.110	0.165
D	0.68	0.94	0.027	0.037
E	3.54	4.00	0.139	0.157
F	14.60	16.00	0.575	0.630
G	13.19	14.79	0.519	0.582
H	2.41	2.67	0.095	0.105
I	4.42	4.76	0.174	0.187
J	1.14	1.40	0.045	0.055
K	5.84	6.86	0.230	0.270
L	2.20	2.80	0.087	0.110
M	0.35	0.64	0.014	0.025

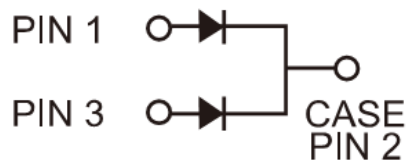

Marking Diagram



P/N = Specific Device Code
 G = Green Compound
 YWW = Date Code