

General Description

The MIC426/427/428 are dual high speed drivers. A TTL/CMOS input voltage level is translated into an output voltage level swing equalling the supply. The DMOS output will be within 25mV of ground or positive supply. Bipolar designs are capable of swinging only within 1 volt of the supply.

The low impedance high current driver outputs will swing a 1000pF load 18V in 30ns. The unique current and voltage drive qualities make the MIC426/427/428 ideal power MOSFET drivers, line drivers and DC to DC converter building blocks.

Input logic signals may equal the power supply voltage. Input current is a low 1μA making direct interface to CMOS/BIPOLAR switch mode power supply control integrated circuits possible as well as open collector analog comparators.

Features

- High Speed Switching ($C_L = 1000\text{pF}$) 30ns
- High Peak Output Current 1.5A
- High Output Voltage Swing $V_S - 25\text{mV}$
GND + 25mV
- Low Input Current (Logic "0" or "1") 1μA
- Low Equivalent Input Capacitance (typ) 6pF
- TTL/CMOS Input Compatible
- Available in Inverting & Non-Inverting Configurations
- Wide Operating Supply Voltage 4.5V to 18V
- Low Power Consumption
(Inputs Low) 0.4mA
(Inputs High) 8mA
- Single Supply Operation
- Low Output Impedance (typ) 6Ω
- Pin Out Equivalent to DS0026 & MMH0026

Pin Configuration

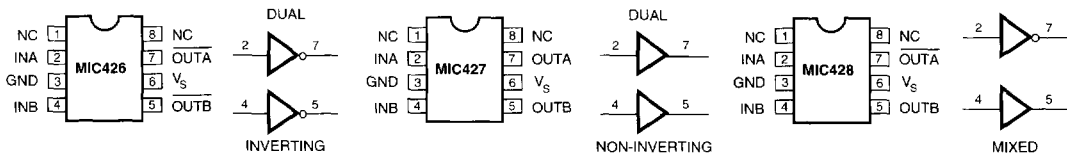

5

Functional Diagram

Integrated Component Count:
4 Resistors
4 Capacitors
52 Transistors

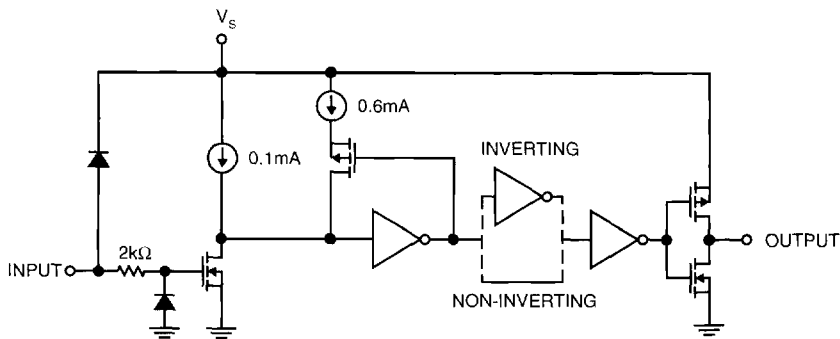

Functional Diagram for One Driver (Two Drivers per Package—Ground Unused Drivers)

Quiescent power supply current is 8mA maximum. The MIC426 requires 1/5 the current of the pin compatible bipolar DS0026 device. This is important in DC to DC converter applications with power efficiency constraints and high frequency switch mode power supply applications. Quiescent current is typically

6mA when driving a 1000pF load 18V at 100kHz.

The inverting MIC426 driver is pin compatible with the bipolar DS0026 and MMH0026 devices. The MIC427 is non-inverting; the MIC428 contains an inverting and non-inverting driver.

Ordering Information

Part Number	Temperature Range	Package	Configuration
MIC426CM MIC426BM	0°C to +70°C -40°C to +85°C	8-pin SOIC	Dual Inverting
MIC426CN MIC426BN	0°C to +70°C -40°C to +85°C	8-pin plastic DIP	Dual Inverting
MIC426AJ MIC426AJBQ*	-55°C to +125°C -55°C to +125°C	8-pin CerDIP	Dual Inverting SMD#5962-8850301PX
MIC426CY	—	CHIP	Dual Inverting
MIC427CM MIC427BM	0°C to +70°C -40°C to +85°C	8-pin SOIC	Dual Non-Inverting
MIC427CN MIC427BN	0°C to +70°C -40°C to +85°C	8-pin plastic DIP	Dual Non-Inverting
MIC427AJ MIC427AJBQ*	-55°C to +125°C -55°C to +125°C	8-pin CerDIP	Dual Non-Inverting SMD#5962-8850302PX
MIC427CY	—	CHIP	Dual Non-Inverting
MIC428CM MIC428BM	0°C to +70°C -40°C to +85°C	8-pin SOIC	Non-Inv. & Inverting
MIC428CN MIC428BN	0°C to +70°C -40°C to +85°C	8-pin plastic DIP	Non-Inv. & Inverting
MIC428AJ MIC428AJBQ*	-55°C to +125°C -55°C to +125°C	8-pin CerDIP	Non-Inv. & Inverting SMD#5962-8850303PX
MIC428CY	—	CHIP	Non-Inv. & Inverting

*AJB indicates units screen to MIL-STD 883, Method 5004, condition B, and burned-in for 1 week. Use SMD (Standard Military Drawing) number for ordering.

Absolute Maximum Ratings (Notes 1, 2, and 3)

If Military/Aerospace specified devices are required, contact Micrel for availability and specifications.

Supply Voltage	20V
Input Voltage Any Terminal	$V_S + 0.3V$ to GND - 0.3V
Maximum Chip Temperature	150°C
Storage Temperature	-65°C to 150°C
Lead Temperature (10 sec)	300°C
Package Thermal Resistance	
CerDIP $R_{\theta J-A}$ (°C/W)	100
CerDIP $R_{\theta J-C}$ (°C/W)	50
PDIP $R_{\theta J-A}$ (°C/W)	130
PDIP $R_{\theta J-C}$ (°C/W)	42
SOIC $R_{\theta J-A}$ (°C/W)	120
SOIC $R_{\theta J-C}$ (°C/W)	75

Operating Temperature Range

C Version	0°C to +70°C
B Version	-40°C to +85°C
A Version	-55°C to +125°C

MIC426/427/428 Electrical Characteristics: $T_A = 25^\circ\text{C}$ with $4.5\text{V} \leq V_S \leq 18\text{V}$ unless otherwise specified.

No.	Symbol	Parameter	Conditions	Min	Typ	Max	Units
INPUT							
1	V_{IH}	Logic 1 Input Voltage		2.4	1.4		V
2	V_{IL}	Logic 0 Input Voltage			1.1	0.8	V
3	I_{IN}	Input Current	$0 \leq V_{IN} \leq V_S$	-1		1	μA
OUTPUT							
4	V_{OH}	High Output Voltage		$V_S - 0.025$			V
5	V_{OL}	Low Output Voltage				0.025	V
6	R_O	Output Resistance	$V_{IN} = 0.8\text{V}$ $I_{OUT} = 10\text{mA}$, $V_S = 18\text{V}$		6	15	Ω
7	R_O	Output Resistance	$V_{IN} = 2.4\text{V}$ $I_{OUT} = 10\text{mA}$, $V_S = 18\text{V}$		6	10	Ω
8	I_{PK}	Peak Output Current			1.5		A
SWITCHING TIME							
9	T_R	Rise Time	Test Figures 1, 2		18	30	ns
10	T_F	Fall Time	Test Figures 1, 2		15	20	ns
11	T_{D1}	Delay Time	Test Figures 1, 2		17	40	ns
12	T_{D2}	Delay Time	Test Figures 1, 2		23	75	ns
POWER SUPPLY							
13	I_S	Power Supply Current	$V_{IN} = 3.0\text{V}$ (Both Inputs)		1.4	8.0	mA
14	I_S	Power Supply Current	$V_{IN} = 0.0\text{V}$ (Both Inputs)		0.18	0.4	mA

MIC426/427/428 Electrical Characteristics:Over operating temperature range with $4.5\text{V} \leq V_S \leq 18\text{V}$ unless otherwise specified.

No.	Symbol	Parameter	Conditions	Min	Typ	Max	Units
INPUT							
1	V_{IH}	Logic 1 Input Voltage		2.4	1.5		V
2	V_{IL}	Logic 0 Input Voltage			1.0	0.8	V
3	I_{IN}	Input Current	$0 \leq V_{IN} \leq V_S$	-10		10	μA

MIC426/427/428 Electrical Characteristics:Over operating temperature range with $4.5V \leq V_S \leq 18V$ unless otherwise specified (Continued).

No.	Symbol	Parameter	Conditions	Min	Typ	Max	Units
OUTPUT							
4	V_{OH}	High Output Voltage		$V_S - 0.025$			V
5	V_{OL}	Low Output Voltage				0.025	V
6	R_O	Output Resistance	$V_{IN} = 0.8V$ $I_{OUT} = 10mA, V_S = 18V$		8	20	Ω
7	R_O	Output Resistance	$V_{IN} = 2.4V$ $I_{OUT} = 10mA, V_S = 18V$		10	15	Ω
SWITCHING TIME							
8	T_R	Rise Time	Test Figures 1, 2		20	60	ns
9	T_F	Fall Time	Test Figures 1, 2		29	40	ns
10	T_{D1}	Delay Time	Test Figures 1, 2		19	60	ns
11	T_{D2}	Delay Time	Test Figures 1, 2		27	120	ns
POWER SUPPLY							
12	I_S	Power Supply Current	$V_{IN} = 3.0V$ (Both Inputs)		1.5	12.0	mA
13	I_S	Power Supply Current	$V_{IN} = 0.0V$ (Both Inputs)		0.19	0.6	mA

Note 1: Functional operation above the absolute maximum stress ratings is not implied.**Note 2:** Static Sensitive device (above 2kV). Unused devices must be stored in conductive material to protect devices from static discharge and static fields.**Note 3:** Switching times guaranteed by design.

Switching Time Test Circuits

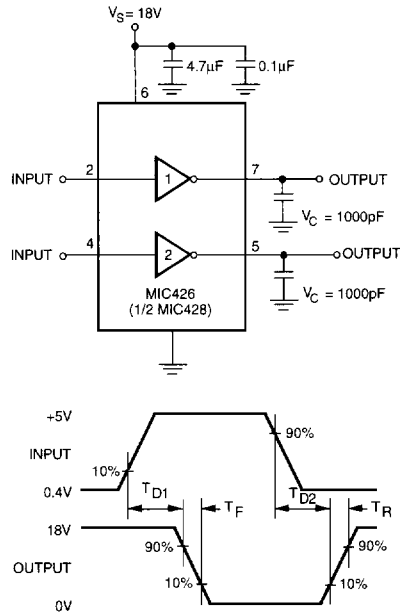

Figure 1. Inverting Driver Switching Time

5

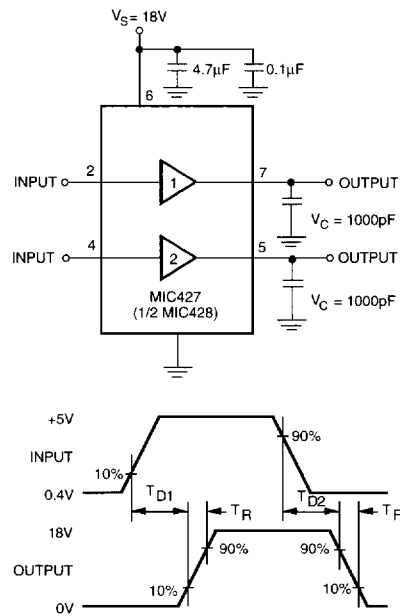
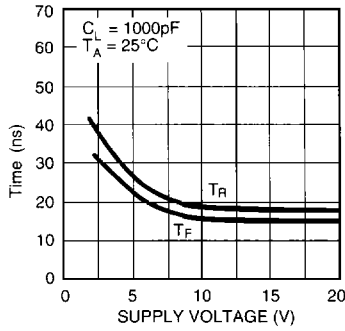

Figure 2. Non-Inverting Driver Switching Time

Typical Characteristic Curves

Rise and Fall Time vs. Supply Voltage



Delay Time vs. Supply Voltage

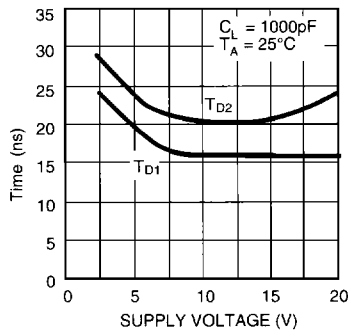

Rise and Fall Time vs. Temperature

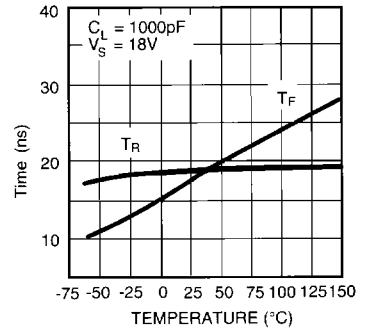

Delay Time vs. Temperature

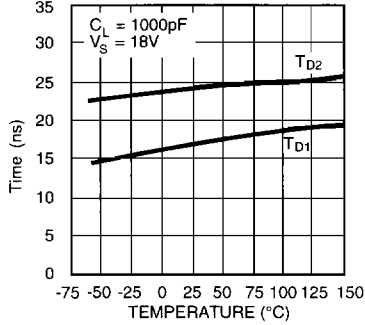

Supply Current vs. Capacitive Load

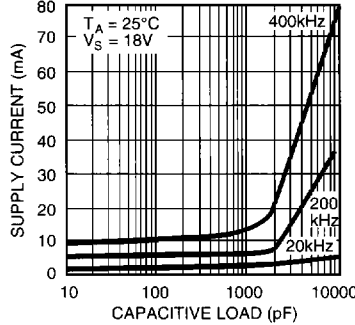

Rise and Fall Time vs. Capacitive Load

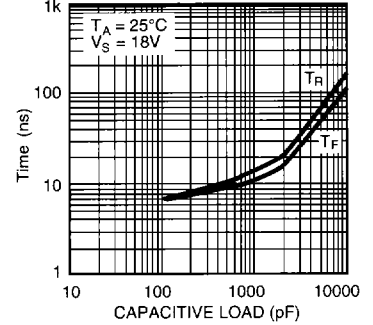

Supply Current vs. Frequency

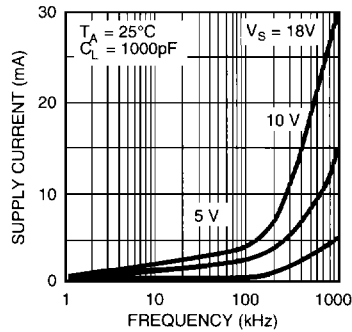

High Output vs. Current

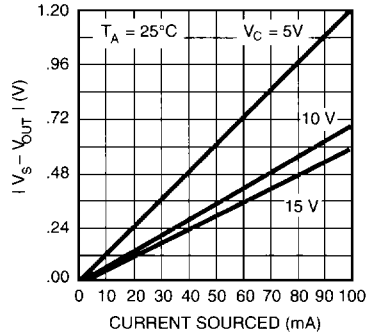

Low Output vs. Current

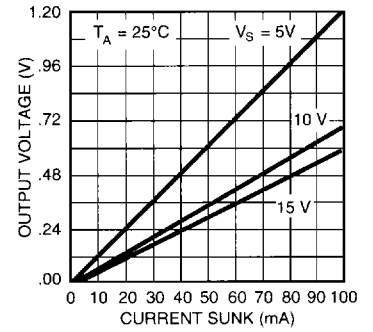

Typical Characteristic Curves (Continued)

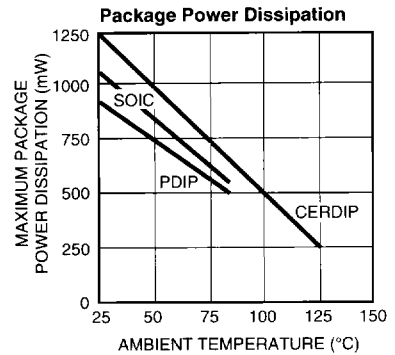
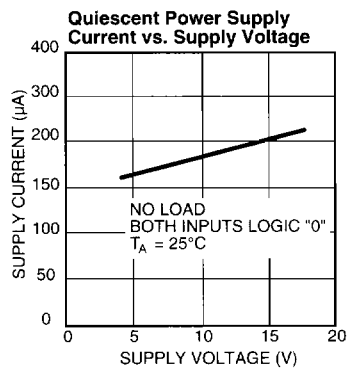
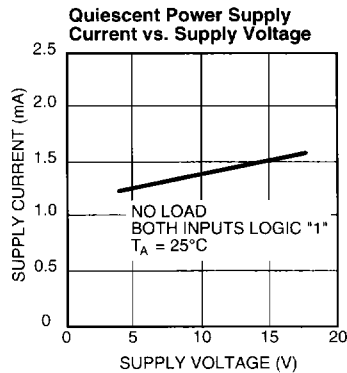

Supply Bypassing

Charging and discharging large capacitive loads quickly requires large currents. For example, changing a 1000pF load 18 volts in 25ns requires a 0.8A current from the device power supply.

To guarantee low supply impedance over a wide frequency range, a parallel capacitor combination is recommended for supply bypassing. Low inductance ceramic disk capacitors with short lead lengths (< 0.5 inch) should be used. A 4.7μF solid tantalum capacitor in parallel with one or two 0.1μF ceramic disk capacitors normally provides adequate bypassing.

Grounding

The MIC426 and MIC428 contain inverting drivers. Ground potential drops developed in common ground impedances from input to output will appear as negative feedback and degrade switching speed characteristics.

Individual ground returns for the input and output circuits or a ground plane should be used.

Input Stage

The input voltage level changes the no load or quiescent supply current. The N channel MOSFET input stage transistor drives a 2.5mA current source load. With a logic "1" input, the maximum quiescent supply current is 8mA. Logic "0" input level signals reduce quiescent current to 400μA maximum. Minimum power dissipation occurs for logic "0" inputs for the MIC426/427/428; unused driver inputs **must be grounded or tied to the positive supply**.

The drivers are designed with 100mV of hysteresis. This provides clean transitions and minimizes output stage current spiking when changing states. Input voltage thresholds are approximately 1.5V making the device TTL compatible over the 4.5V to 18V operating supply range. Input current is less than 1μA over this range.

The MIC426/427/428 may be directly driven by the TL494, SG1526/1527, SG1524, SE5560 and similar switch mode power supply integrated circuits.

Power Dissipation

The supply current vs. frequency and supply current vs. capacitive load characteristic curves will aid in performing power dissipation calculations.

The MIC426/427/428 CMOS drivers have greatly reduced quiescent DC power consumption. Maximum quiescent current is 8mA compared to the DS0026 40mA specification. For a 15V supply, power dissipation is typically 40mW.

Two other power dissipation components are:

- Output stage AC and DC load power.
- Transition state power.

Output stage power is:

$$P_O = P_{DC} + P_{AC} = V_O (I_{DC}) + f C_L V_S^2$$

Where: V_O = DC output voltage
 I_{DC} = DC output load current
 f = Switching frequency
 V_S = Supply voltage

In power MOSFET drive applications, the P_{DC} term is negligible. MOSFET power transistors are high impedance, capacitive input devices. In applications where resistive loads or relays are driven, the P_{DC} component will normally dominate.

The magnitude of P_{AC} is readily estimated for several cases:

- | | |
|---------------------------|---------------------------|
| A. 1. $f = 200\text{kHz}$ | B. 1. $f = 200\text{kHz}$ |
| 2. $C_L = 1000\text{pF}$ | 2. $C_L = 1000\text{pF}$ |
| 3. $V_S = 18\text{V}$ | 3. $V_S = 15\text{V}$ |
| 4. $P_{AC} = 65\text{mW}$ | 4. $P_{AC} = 45\text{mW}$ |

During output level state changes, a current surge will flow through the series connected N and P channel output MOSFETs as one device is turning "ON" while the other is

turning "OFF." The current spike flows only during output transitions. The input levels should not be maintained between the logic "0" and logic "1" levels. **Unused driver inputs must be tied to ground and not be allowed to float.** Average

power dissipation will be reduced by minimizing input rise times. As shown in the characteristic curves, average supply current is frequency dependent.

Voltage Doubler

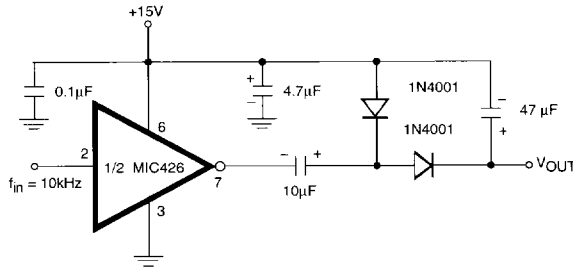

OUTPUT VOLTAGE vs LOAD CURRENT

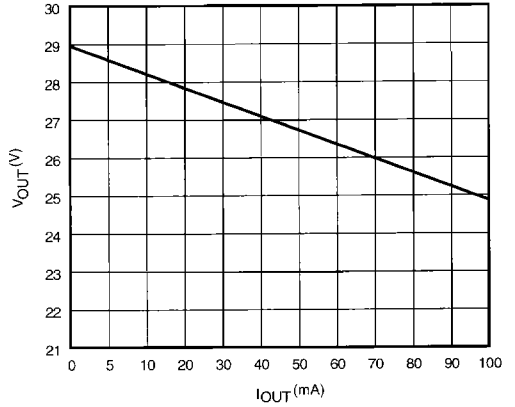

Voltage Inverter

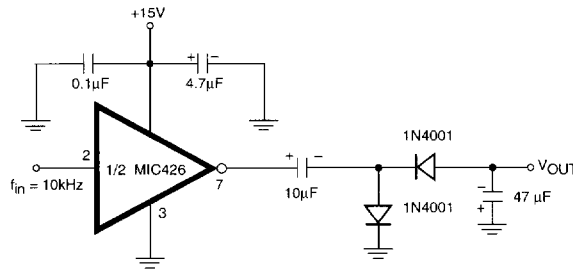

OUTPUT VOLTAGE vs LOAD CURRENT

