

DM74AS169A

Synchronous 4-Bit Binary Up/Down Counter

Features

- Switching Specifications at 50pF
- Switching Specifications guaranteed over full temperature and V_{CC} range
- Advanced oxide-isolated, ion-implanted Schottky TTL process
- Functionally and pin-for-pin compatible with Schottky and low power Schottky TTL counterpart
- Improved AC performance over Schottky and low power Schottky counterparts
- Synchronously programmable
- Internal look ahead for fast counting
- Carry output for n-bit cascading
- Synchronous counting
- Load control line
- ESD inputs

General Description

These synchronous presettable counters feature an internal carry look ahead for cascading in high speed counting applications. The DM74AS169 is a 4-bit binary up/down counter. The carry output is decoded to prevent spikes during normal mode of counting operation. Synchronous operation is provided so that outputs change coincident with each other when so instructed by count enable inputs and internal gating. This mode of operation eliminates the output counting spikes which are normally associated with asynchronous (ripple clock) counters. A buffered clock input triggers the four flip-flops on the rising (positive going) edge of clock input waveform.

These counters are fully programmable; that is, the outputs may each be preset either HIGH or LOW. The load input circuitry allows loading with carry-enable output of cascaded counters. As loading is synchronous, setting up a LOW level at the load input disables the counter and causes the outputs to agree with the data inputs after the next clock pulse.

The carry look-ahead circuitry permits cascading counters for n-bit synchronous applications without additional gating. Both count enable inputs (\bar{P} and \bar{T}) must be LOW to count. The direction of the count is determined by the level of the up/down input. When the input is HIGH, the counter counts UP; when LOW, it counts DOWN. Input T is fed forward to enable the carry outputs. The carry output thus enabled will produce a LOW level output pulse with a duration approximately equal to the HIGH portion of the QA output when counting UP, and approximately equal to the LOW portion of the QA output when counting DOWN. This LOW level overflow carry pulse can be used to enable successively cascaded stages. Transitions at the enable \bar{P} or \bar{T} inputs are allowed regardless of the level of the clock input.

The control functions for these counters are fully synchronous. Changes at control inputs (enable \bar{P} , enable \bar{T} , load, up/down) which modify the operating mode have no effect until clocking occurs. The function of the counter (whether enabled, disabled, loading or counting) will be dictated solely by the conditions meeting the stable setup and hold times.

Ordering Information

Order Number	Package Number	Package Description
DM74AS169AM	M16A	16-Lead Small Outline Integrated Circuit (SOIC), JEDEC MS-012, 0.150" Narrow

Devices also available in Tape and Reel. Specify by appending the suffix letter "X" to the ordering number.

Connection Diagram

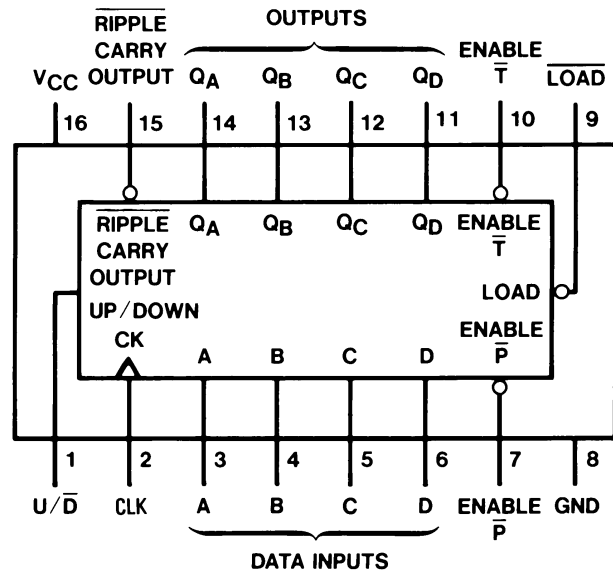

Logic Diagram

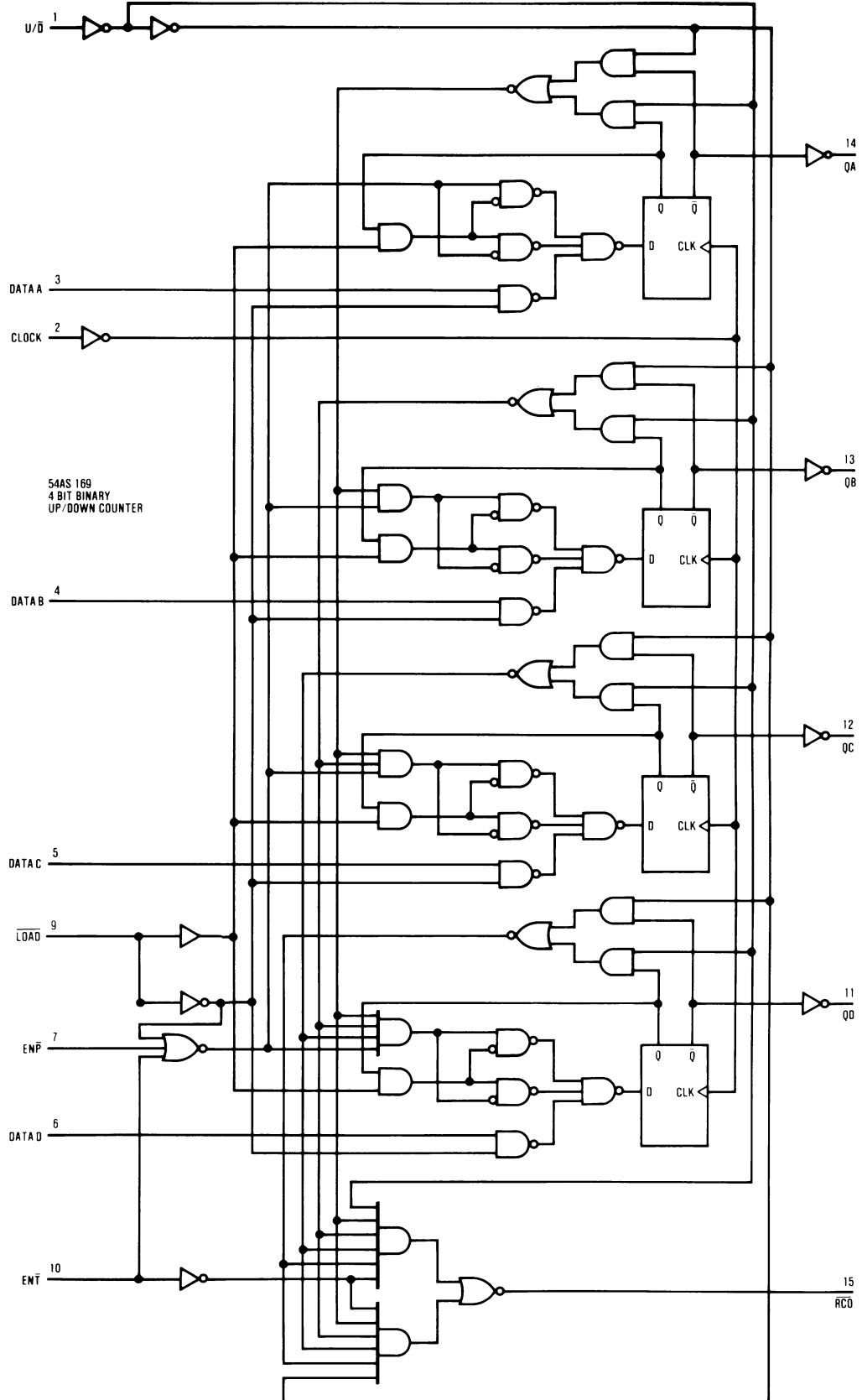

Absolute Maximum Ratings

Stresses exceeding the absolute maximum ratings may damage the device. The device may not function or be operable above the recommended operating conditions and stressing the parts to these levels is not recommended. In addition, extended exposure to stresses above the recommended operating conditions may affect device reliability. The absolute maximum ratings are stress ratings only.

Symbol	Parameter	Rating
V_{CC}	Supply Voltage	7V
V_I	Input Voltage	7V
T_A	Operating Free Air Temperature Range	0°C to +70°C
T_{STG}	Storage Temperature Range	-65°C to +150°C
θ_{JA}	Typical Thermal Resistance	101.0°C/W

Recommended Operating Conditions

The Recommended Operating Conditions table defines the conditions for actual device operation. Recommended operating conditions are specified to ensure optimal performance to the datasheet specifications. Fairchild does not recommend exceeding them or designing to absolute maximum ratings.

Symbol	Parameter	Min.	Nom.	Max.	Units
V_{CC}	Supply Voltage	4.5	5	5.5	V
V_{IH}	HIGH Level Input Voltage	2			V
V_{IL}	LOW Level Input Voltage			0.8	V
I_{OH}	HIGH Level Output Current			-2	mA
I_{OL}	LOW Level Output Current			20	mA
f_{CLK}	Clock Frequency	0		75	MHz
t_{SU}	t_{setup} , Set-up Time	Data; A, B, C, D	8		ns
		En \bar{P} , En \bar{T}	8		
		\overline{LOAD}	8		
		U/\bar{D}	11		
t_H	t_{hold} , Hold Time	Data; A, B, C, D	0		ns
		En \bar{P} , En \bar{T}	0		
		\overline{LOAD}	0		
		U/\bar{D}	0		
t_{WCLK}	Width of Clock Pulse	6.7			ns
t_A	Free Air Operating Temperature	0		70	°C

Electrical Characteristics

Over recommended operating free air temperature range. All typical values are measured at $V_{CC} = 5V$, $T_A = 25^\circ C$.

Symbol	Parameter	Conditions	Min.	Typ.	Max.	Units
V_{IK}	Input Clamp Voltage	$V_{CC} = 4.5V$, $I_I = -18mA$			-1.2	V
V_{OH}	HIGH Level Output Voltage	$I_{OH} = -2 mA$, $V_{CC} = 4.5V$ to $5.5V$	$V_{CC} - 2$			V
V_{OL}	LOW Level Output Voltage	$V_{CC} = 4.5V$, $I_{OL} = 20mA$		0.35	0.5	V
I_I	Input Current @ Max. Input Voltage	$V_{CC} = 5.5V$, $V_{IH} = 7V$	LOAD, \overline{ENT} , U/\overline{D}		0.2	mA
			Others		0.1	
I_{IH}	HIGH Level Input Current	$V_{CC} = 5.5V$, $V_{IH} = 2.7V$	LOAD, \overline{ENT} , U/\overline{D}		40	μA
			Others		20	
I_{IL}	LOW Level Input Current	$V_{CC} = 5.5V$, $V_{IL} = 0.4V$	CLK, DATA, \overline{ENP}		-0.5	mA
			LOAD, \overline{ENT} , U/\overline{D}		-1	
$I_O^{(1)}$	Output Drive Current	$V_{CC} = 5.5V$, $V_O = 2.25V$	-30		-112	mA
I_{CC}	Supply Current	$V_{CC} = 5.5V$		46	63	mA

Note:

- The output conditions have been chosen to produce a current that closely approximates one half of the true short circuit output current, I_{OS} .

Switching Characteristics

Over recommended operating free air temperature range.

Symbol	Parameter	Conditions	From	To	Min	Max	Units
f_{MAX}	Maximum Clock Frequency	$V_{CC} = 4.5V$ to $5.5V$,			75		MHz
t_{PLH}	Propagation Delay Time, LOW-to-HIGH Level Output	$R_L = 500\Omega$, $C_L = 50pF$	Clock	\overline{RIPPLE} Carry	3	16.5	ns
t_{PHL}	Propagation Delay Time, HIGH-to-LOW Level Output		Clock	\overline{RIPPLE} Carry	2	13	ns
t_{PLH}	Propagation Delay Time, LOW-to-HIGH Level Output		Clock	Any Q	1	7	ns
t_{PHL}	Propagation Delay Time, HIGH-to-LOW Level Output		Clock	Any Q	2	13	ns
t_{PLH}	Propagation Delay Time, LOW-to-HIGH Level Output		$En \overline{T}$	\overline{RIPPLE} Carry	1.5	9	ns
t_{PHL}	Propagation Delay Time, HIGH-to-LOW Level Output		$En \overline{T}$	\overline{RIPPLE} Carry	1.5	9	ns
t_{PLH}	Propagation Delay Time, LOW-to-HIGH Level Output		$U/\overline{D}^{(2)}$	\overline{RIPPLE} Carry	2	12	ns
t_{PHL}	Propagation Delay Time, HIGH-to-LOW Level Output		$U/\overline{D}^{(2)}$	\overline{RIPPLE} Carry	2	13	ns

Note:

- Propagation delay time from up/down to ripple carry must be measured with the counter at either a minimum or a maximum count. As the logic level of the up/down input is changed, the ripple carry output will follow. If the count is minimum (0), the ripple carry output transition will be in phase. If the count is maximum, the ripple carry output will be out of phase.



TRADEMARKS

The following are registered and unregistered trademarks and service marks Fairchild Semiconductor owns or is authorized to use and is not intended to be an exhaustive list of all such trademarks

ACEx®	Green FPS™ e-Series™	Power-SPM™	SyncFET™
Build it Now™	GTO™	PowerTrench®	The Power Franchise®
CorePLUS™	<i>i-Lo</i> ™	Programmable Active Droop™	 ™
CROSSVOLT™	IntelliMAX™	QFET®	TinyBoost™
CTL™	ISOPLANAR™	QS™	TinyBuck™
Current Transfer Logic™	MegaBuck™	QT Optoelectronics™	TinyLogic®
EcoSPARK®	MICROCOUPLER™	Quiet Series™	TINYOPTO™
FACT Quiet Series™	MicroPak™	RapidConfigure™	TinyPower™
FACT®	Motion-SPM™	SMART START™	TinyPWM™
FAST®	OPTOLOGIC®	SPM®	TinyWire™
FastvCore™	OPTOPLANAR®	STEALTH™	μSerDes™
FPS™	PDP-SPM™	SuperFET™	UHC®
FRFET®	Power220®	SuperSOT™-3	UniFET™
Global Power Resource™	Power247®	SuperSOT™-6	VCX™
Green FPS™	POWEREDGE®	SuperSOT™-8	

DISCLAIMER

FAIRCHILD SEMICONDUCTOR RESERVES THE RIGHT TO MAKE CHANGES WITHOUT FURTHER NOTICE TO ANY PRODUCTS HEREIN TO IMPROVE RELIABILITY, FUNCTION, OR DESIGN. FAIRCHILD DOES NOT ASSUME ANY LIABILITY ARISING OUT OF THE APPLICATION OR USE OF ANY PRODUCT OR CIRCUIT DESCRIBED HEREIN; NEITHER DOES IT CONVEY ANY LICENSE UNDER ITS PATENT RIGHTS, NOR THE RIGHTS OF OTHERS. THESE SPECIFICATIONS DO NOT EXPAND THE TERMS OF FAIRCHILD'S WORLDWIDE TERMS AND CONDITIONS, SPECIFICALLY THE WARRANTY THEREIN, WHICH COVERS THESE PRODUCTS.

LIFE SUPPORT POLICY

FAIRCHILD'S PRODUCTS ARE NOT AUTHORIZED FOR USE AS CRITICAL COMPONENTS IN LIFE SUPPORT DEVICES OR SYSTEMS WITHOUT THE EXPRESS WRITTEN APPROVAL OF FAIRCHILD SEMICONDUCTOR CORPORATION.

As used herein:

- Life support devices or systems are devices or systems which, (a) are intended for surgical implant into the body, or (b) support or sustain life, and (c) whose failure to perform when properly used in accordance with instructions for use provided in the labeling, can be reasonably expected to result in significant injury to the user.
- A critical component is any component of a life support device or system whose failure to perform can be reasonably expected to cause the failure of the life support device or system, or to affect its safety or effectiveness.

PRODUCT STATUS DEFINITIONS

Definition of Terms

Datasheet Identification	Product Status	Definition
Advance Information	Formative or In Design	This datasheet contains the design specifications for product development. Specifications may change in any manner without notice.
Preliminary	First Production	This datasheet contains preliminary data; supplementary data will be published at a later date. Fairchild Semiconductor reserves the right to make changes at any time without notice to improve design.
No Identification Needed	Full Production	This datasheet contains final specifications. Fairchild Semiconductor reserves the right to make changes at any time without notice to improve design.
Obsolete	Not In Production	This datasheet contains specifications on a product that has been discontinued by Fairchild semiconductor. The datasheet is printed for reference information only.

Rev. I28