

## DS7640/DS8640 Quad NOR Unified Bus Receiver

### General Description

The DS7640 and DS8640 are quad 2-input receivers designed for use in bus organized data transmission systems interconnected by terminated 120 $\Omega$  impedance lines. The external termination is intended to be 180 $\Omega$  resistor from the bus to the +5V logic supply together with a 390 $\Omega$  resistor from the bus to ground. The design employs a built-in input threshold providing substantial noise immunity. Low input current allows up to 27 driver/receiver pairs to utilize a common bus.

### Features

- Low input current with normal  $V_{CC}$  or  $V_{CC} = 0V$  (30  $\mu A$  typ)
- High noise immunity (1.1V typ)
- Temperature-insensitive input thresholds track bus logic levels
- TTL compatible output
- Matched, optimized noise immunity for "1" and "0" levels
- High speed (19 ns typ)

### Connection Diagram

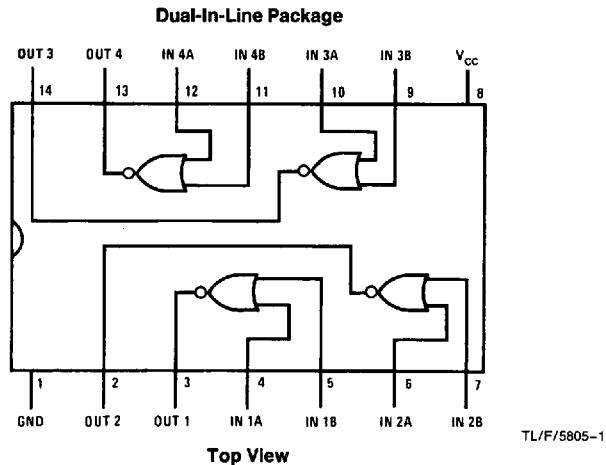

Order Number DS7640J or DS8640N  
See NS Package Number J14A or N14A

### Typical Application

#### 120 $\Omega$ Unified Data Bus

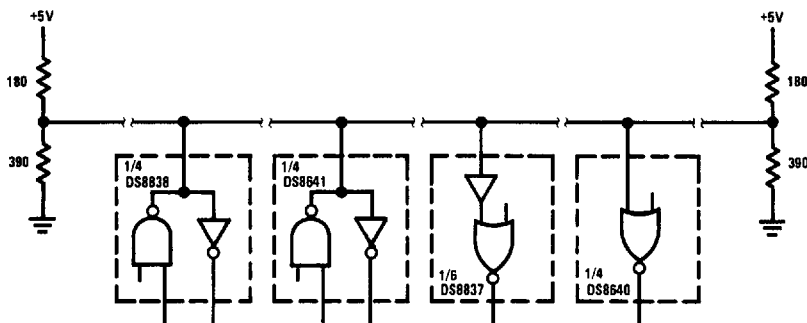

### Absolute Maximum Ratings (Note 1)

If Military/Aerospace specified devices are required, please contact the National Semiconductor Sales Office/Distributors for availability and specifications.

Supply Voltage	7.0V
Input Voltage	5.5V
Storage Temperature Range	-65°C to +150°C
Maximum Power Dissipation* at 25°C	
Cavity Package	1308 mW
Molded Package	1207 mW
Lead Temperature (Soldering, 4 seconds)	260°C

\*Derate cavity package 8.7 mW/°C above 25°C; derate molded package 9.7 mW/°C above 25°C.

### Operating Conditions

	Min	Max	Units
Supply Voltage (V <sub>CC</sub> )			
DS7640	4.5	5.5	V
DS8640	4.75	5.25	V
Temperature (T <sub>A</sub> )			
DS7640	-55	+125	°C
DS8640	0	+70	°C

### Electrical Characteristics

The following apply for V<sub>MIN</sub> ≤ V<sub>CC</sub> ≤ V<sub>MAX</sub>, T<sub>MIN</sub> ≤ T<sub>A</sub> ≤ T<sub>MAX</sub>, unless otherwise specified (Notes 2 and 3)

Symbol	Parameter	Conditions	Min	Typ	Max	Units
V <sub>IH</sub>	High Level Input Threshold	V <sub>OUT</sub> = V <sub>OL</sub>				
		DS7640	1.80	1.50		V
		DS8640	1.70	1.50		V
V <sub>IL</sub>	Low Level Input Threshold	V <sub>OUT</sub> = V <sub>OH</sub>				
		DS7640		1.50	1.20	V
		DS8640		1.50	1.30	V
I <sub>IH</sub>	Maximum Input Current	V <sub>IN</sub> = 4V				
		V <sub>CC</sub> = V <sub>MAX</sub>		30	80	μA
		V <sub>CC</sub> = 0V		1.0	50	μA
I <sub>IL</sub>	Maximum Input Current	V <sub>IN</sub> = 0.4V, V <sub>CC</sub> = V <sub>MAX</sub>		1.0	50	μA
V <sub>OH</sub>	Output Voltage	I <sub>OH</sub> = -400 μA, V <sub>IN</sub> = V <sub>IL</sub>	2.4			V
V <sub>OL</sub>	Output Voltage	I <sub>OL</sub> = 16 mA, V <sub>IN</sub> = V <sub>IH</sub>		0.25	0.4	V
I <sub>OS</sub>	Output Short Circuit Current	V <sub>IN</sub> = 0.5V, V <sub>OS</sub> = 0V, V <sub>CC</sub> = V <sub>MAX</sub> . (Note 4)	-18		-55	mA
I <sub>CC</sub>	Power Supply Current	V <sub>IN</sub> = 4V, (Per Package)		25	40	mA

### Switching Characteristics T<sub>A</sub> = 25°C, nominal power supplies unless otherwise noted

Symbol	Parameter	Conditions	Min	Typ	Max	Units
t <sub>pd</sub>	Propagation Delays	(Notes 5 and 6)				
		Input to Logic "1" Output	10	23	35	ns
		Input to Logic "0" Output	10	15	30	ns

**Note 1:** "Absolute Maximum Ratings" are those values beyond which the safety of the device cannot be guaranteed. Except for "Operating Temperature Range" they are not meant to imply that the devices should be operated at these limits. The table of "Electrical Characteristics" provides conditions for actual device operation.

**Note 2:** Unless otherwise specified min/max limits apply across the -55°C to +125°C temperature range for the DS7640 and across the 0°C to +70°C range for the DS8640. All typical values are T<sub>A</sub> = 25°C and V<sub>CC</sub> = 5V.

**Note 3:** All currents into device pins shown as positive, out of device pins as negative, all voltages referenced to ground unless otherwise noted. All values shown as max or min on absolute value basis.

**Note 4:** Only one output at a time should be shorted.

**Note 5:** Fan-out of 10 load, C<sub>LOAD</sub> = 15 pF total, measured from V<sub>IN</sub> = 1.5V to V<sub>OUT</sub> = 1.5V, V<sub>IN</sub> = 0V to 3V pulse.

**Note 6:** Apply to V<sub>CC</sub> = 5V, T<sub>A</sub> = 25°C.