

DRAWING FOR REFERENCE: This is subject to change without notice
08/11/2012

TO

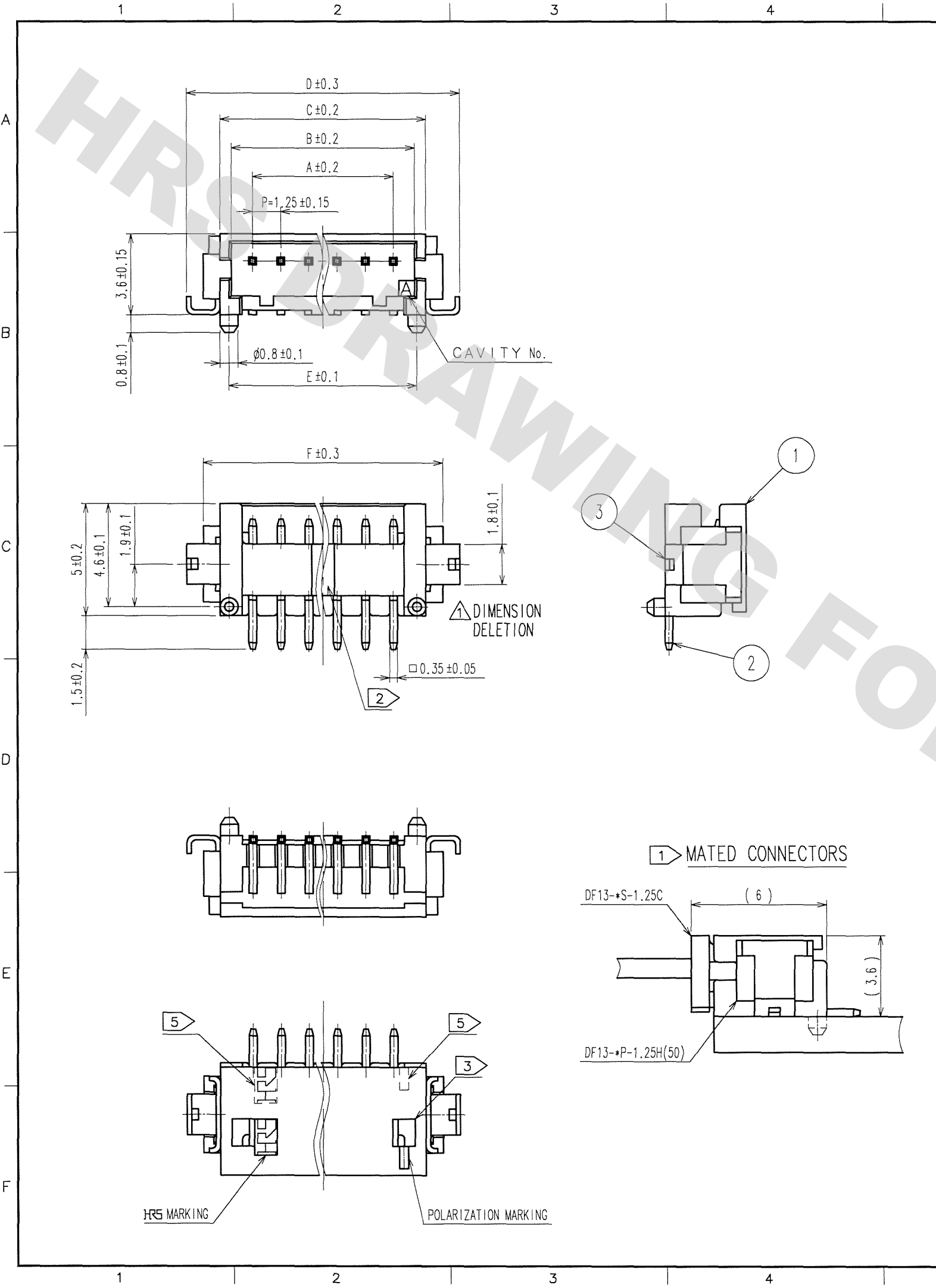

COUNT	DESCRIPTION OF REVISIONS	BY	CHKD	DATE	COUNT	DESCRIPTION OF REVISIONS	BY	CHKD	DATE
1	DIS-H-001671	T.K	H.U	07.01.18					

CODE No.	PARTS No.	NUMBER OF CONTACT	A	B	C	D	E	F
CL536-0251-1-50	DF13- 2P-1.25H(50)	2	1.25	3.15	4.15	7.15	3.35	5.65
CL536-0252-4-50	DF13- 3P-1.25H(50)	3	2.5	4.4	5.4	8.4	4.60	6.9
CL536-0253-7-50	DF13- 4P-1.25H(50)	4	3.75	5.65	6.65	9.65	5.85	8.15
CL536-0254-0-50	DF13- 5P-1.25H(50)	5	5.0	6.9	7.9	10.9	7.10	9.40
CL536-0255-2-50	DF13- 6P-1.25H(50)	6	6.25	8.15	9.15	12.15	8.35	10.65
CL536-0256-5-50	DF13- 7P-1.25H(50)	7	7.5	9.4	10.4	13.4	9.60	11.9
CL536-0257-8-50	DF13- 8P-1.25H(50)	8	8.75	10.65	11.65	14.65	10.85	13.15
CL536-0258-0-50	DF13- 9P-1.25H(50)	9	10.0	11.9	12.9	15.9	12.1	14.4
CL536-0259-3-50	DF13-10P-1.25H(50)	10	11.25	13.15	14.15	17.15	13.35	15.65
CL536-0260-2-50	DF13-11P-1.25H(50)	11	12.5	14.4	15.4	18.4	14.6	16.9
CL536-0261-5-50	DF13-12P-1.25H(50)	12	13.75	15.65	16.65	19.65	15.85	18.15
CL536-0263-0-50	DF13-14P-1.25H(50)	14	16.25	18.15	19.15	22.15	18.35	20.65
CL536-0264-3-50	DF13-15P-1.25H(50)	15	17.5	19.4	20.4	23.4	19.6	21.9

RECOMMENDED PATTERN

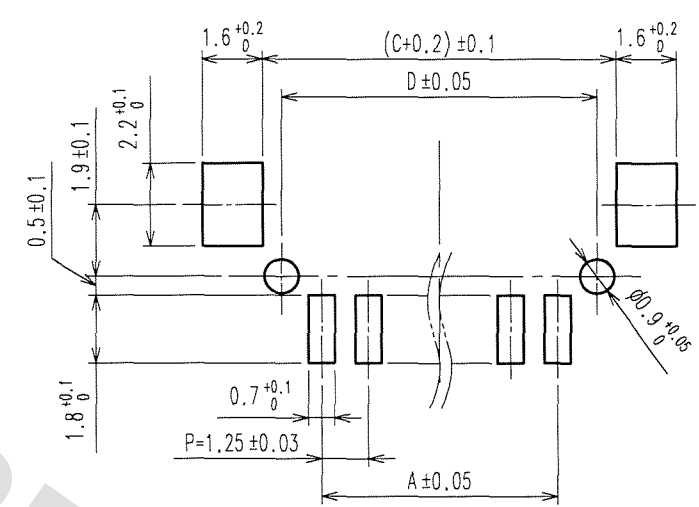

- NOTE
- 1: WHEN THIS CONNECTOR MATES WITH DF13-*S-1.25C THE MATING LENGTH IS 3.6 mm.
 - 2: THERE SHALL BE STANDOFF MORE THAN FIVE CONTACTS.
 - 3: WHEN THIS CONNECTOR HAS TWO OR THREER CONTACTS, THE LOCK SHALL BE SET AT THE CENTER OF HOUSING. IF MORE THAN FOUR, THE TWO LOCKS SHALL BE SET AS SHOWN ON THIS DRAWING.
 - 4: FLATNESS OF LEAD WITH REINFORCED METAL FITTINGS SHALL BE WITHIN 0.1mm.
 - 5: WHEN THIS CONNECTOR HAS MORE THAN SEVEN CONTACTS, HRS MARKING AND POLARIZATION MARKING SHIFT TO THE PLACE INDICATING DOTTED LINES.

2	BRASS	SURFACE PLATING:GOLD PLATED 0.2 μ m min UNDER PLATING:NICKEL PLATDE 0.5 μ m min	5	S.PVC	STOPPER
1	POLYAMIDE	BEIGE(NATURAL), UL94V-0	4	PVC	TUBE
NO.	MATERIAL	FINISH, REMARKS	NO.	MATERIAL	FINISH, REMARKS

CODE NO. (OLD)	DRAWN	DESIGNED	CHECKED	APPROVED	RELEASED
CL	T.Kumazawa	T.Kumazawa	H.Umehara	T.Oma	
	'05.03.11	'05.03.11	'05.03.15	'05.03.15	

SCALE	DRAWING NO.	PART NO.
5 : 1	EDC3-083662-03	DF13-*P-1.25H(50)
UNITS	HRS	CODE NO.
mm	HIROSE ELECTRIC CO., LTD	CL536-

1/2

1

2

3

4

5

6

7

8

COUNT	DESCRIPTION OF REVISIONS	BY	CHKD	DATE	COUNT	DESCRIPTION OF REVISIONS	BY	CHKD	DATE
△				..	△				..
△				..	△				..
△				..	△				..

A

B

C

D

E

F

510⁰/₋₂

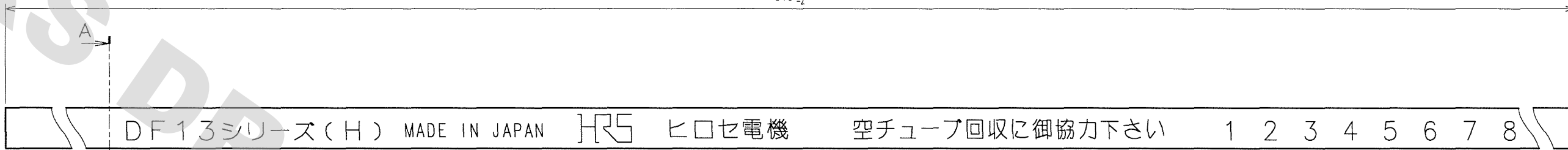
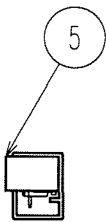

DF13シリーズ(H) MADE IN JAPAN HRS ヒロセ電機 空チューブ回収に御協力下さい 1 2 3 4 5 6 7 8

CODE No.	PARTS No.	QUANTITY OF CONNECTOR
CL536-0251-1-50	DF13- 2P-1.25H(50)	67
CL536-0252-4-50	DF13- 3P-1.25H(50)	57
CL536-0253-7-50	DF13- 4P-1.25H(50)	49
CL536-0254-0-50	DF13- 5P-1.25H(50)	44
CL536-0255-2-50	DF13- 6P-1.25H(50)	39
CL536-0256-5-50	DF13- 7P-1.25H(50)	36
CL536-0257-8-50	DF13- 8P-1.25H(50)	33
CL536-0258-0-50	DF13- 9P-1.25H(50)	30
CL536-0259-3-50	DF13-10P-1.25H(50)	28
CL536-0260-2-50	DF13-11P-1.25H(50)	26
CL536-0261-5-50	DF13-12P-1.25H(50)	24
CL536-0263-0-50	DF13-14P-1.25H(50)	21
CL536-0264-3-50	DF13-15P-1.25H(50)	20

A-A(10:1)

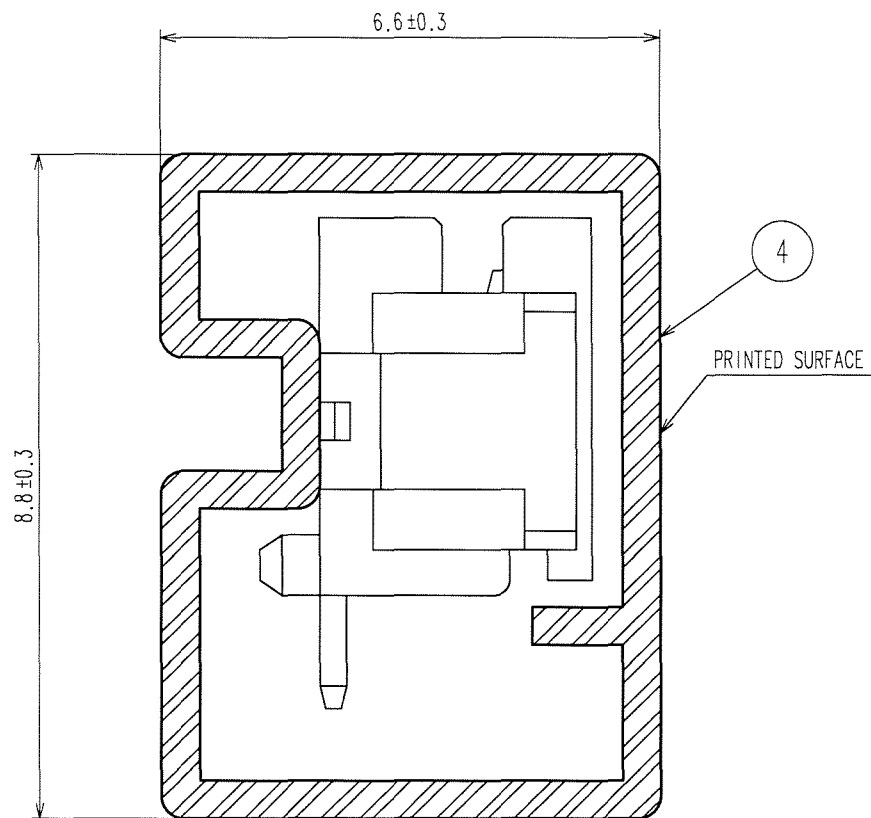

NOTES 6 : THE TUBE HAS ONE STOPPER AT EACH END.
 7 : WARPAGE OF THE TUBE SHALL BE ALLOWED ±0.2mm PER 510mm.
 8 : MINIMUM UNIT OF PURCHASE SHALL BE THE QUANTITY OF CONNECTORS IN TUBE.

NO.	MATERIAL	FINISH, REMARKS	NO.	MATERIAL	FINISH, REMARKS		
CODE NO. (OLD) CL			DRAWN	DESIGNED	CHECKED	APPROVED	RELEASED
			T.Kumazawa	T.Kumazawa	H.Umehara	T.Oma	
			'05.03.11	'05.03.11	'05.03.15	'05.03.15	
SCALE 5 : 1	DRAWING NO. EDC3-083662-03		PART NO. DF13-*P-1.25H(50)				
UNITS mm	HRS HIROSE ELECTRIC CO., LTD		CODE NO. CL536-		2		

DRAWING FOR REFERENCE: This is subject to change without notice
08/11/2012

TO

1

2

3

4

5

6

7

8

FORM NO. 229